

Manual

LOGO 700



Mikado
Model Helicopters

Index

Safety Instructions/ Tools for Assembly & RC Equipment	2
1 Chassis	3
1 Chassis and Landing Struts	5
2 Servo Mounting	7
3 Main Gear	8
4 Motor Installation	9
5 Tail Rotor	10
6 Torque Tube	11
7 Tail Boom Mounting	12
8 Tail Boom Brace	13
9 Swashplate	14
10 Rotor Head	15
11 Rotor Head Linkage	16
12 Wiring RC Components	17
13 Mounting ESC/ Battery	18
14 Canopy and Overview	19
15 Overview Spare Parts Mainframe	20
16 Overview Spare Parts Tail Boom	23
17 Overview Spare Parts Tail Rotor	24
18 Overview Spare Parts Rotor Head	25

Thank you very much for your purchase of the Mikado LOGO 700. Prior to installation, please read and understand this manual completely and follow all instructions exactly. If any instructions are not clear to you or if you have any questions, you must contact us. You can reach Mikado on the LOGO-Forum on www.vstabi.info or contact the Mikado support hotline via email or phone. Do not under any circumstances fly this helicopter if you are unsure of setup or assembly.

This helicopter is not suitable for beginners. It is expected that you have some experience in assembling and operating an RC helicopter (model size LOGO 400 to LOGO 600, for example). You are required to adhere to the safety instructions of this manual.

The LOGO 700 comes partially pre-assembled, i.e. the structural components are already screwed together. However, the screws are not yet secured with Loctite. Throughout the manual you will not always be asked to secure each screw. Nevertheless, you must secure all screws in all components yourself. In addition, it is necessary that you secure all other screwed connection, by which you will assemble the different components of the LOGO. We recommended to use securing glue Loctite 243 (blue). Please follow the recommendations of the Loctite manufacture and allow proper curing time for the Loctite prior to flying the model.

Safety Instructions:

RC Helicopters are not toys and must be treated with due diligence. Unless you use this helicopter responsibly it can cause of severe injury and immense damage. Inappropriate use of this product can result in injury or death. Each user must have the appropriate knowledge and skill to operate any RC Helicopter. Manufacturer / reseller assumes no liability for the use or operation of this helicopter.

You are responsible for any injury and damage that may be caused by this helicopter. It is recommended that your radio components be tested prior to installing in this helicopter. Improper radio installation or inadequate battery voltage can result in the loss of control of the helicopter. Proper knowledge of your radio equipment is required prior to flying this helicopter. You must check if other persons are using an RC-controlled model or device simultaneously, as this may result in interference. If the helicopter behaves in an unusual or strange way, you must land it immediately and turn off the power. Please meticulously check all of your radio gear and find/fix the problem before you continue to operate the helicopter This is to avoid any accidents. As one irregularity can cause other defects or problems, an increased risk of failure will ensue, if the first problem is not fixed.

Additional precautions for the prevention of injuries or damage:

Before you power on the helicopter, you must ensure that all screws and associated hardware are secured. One single lose screw can cause the helicopter to become uncontrollable resulting in a crash or injury to personnel.

Also it is very important that you must check the model frequently and exchange any parts that show signs of deterioration or wear. Failure to complete frequent pre and post flight inspections will result in flying an unsafe model and increasing the risk of damaging the helicopter and possibly injuring yourself and/or others. Use only original Mikado parts and electronic components which are recommended by Mikado.

Always keep a minimum of 10 yards away from a spinning rotor head. Components that run hot such as the ESC and Motor should never be touched until ample cool down time has been provided.

Perform overspeed maneuvers only at your own risk: overspeed maneuvers may overload the components on the helicopter and lead to damage/a crash/injury.

Before powering on the helicopter:

Never operate the helicopter inside closed rooms as this helicopter is intended for operation outside and may only be operated in sites where operation of Radio Control models is permitted. . Keep the helicopter at safe distance to any persons or live animals at all times. When trimming, keep a minimum distance of 10 yards for safety and never operate the helicopter alone. Always take someone with you, who can help in emergency situations.

The helicopter must also not be operated in the following circumstances:

- when children are present or in places where people are gathering
- close to houses or in park areas
- inside any rooms or buildings
- places with limited space
- in adverse weather conditions, such as rain, snow, hail or during strong winds
- Near trees or High Tension wires

Technical specifications which must be obeyed during the operation of the LOGO 700:

- maximum rotor head rpm: 2100 U/min.
- maximum pitch travel: +/- 12°
- Length of rotor blades: 690 to 717mm
- Lipo battery: 2x 6S 4.500 to 5.500 mAh
- admissible temperature 5° - 35° Celsius

If these values are exceeded, the electronic components may experience overload. This may result in damage or a crash of the helicopter.

Before the first flight, you must check proper functioning of the motor, the ESC and the VBar. To do this, please refer to the respective manuals. For safety reasons, these tests should be performed without mounting the main rotor blades and the tail rotor blades. It is advisable to fly moderately during the first flights. This is because you need to get used to the new size of this helicopter during the first few flights. Do not underestimate the size and power of this helicopter. Keep a safe distance from the ground to provide for ample reaction time.

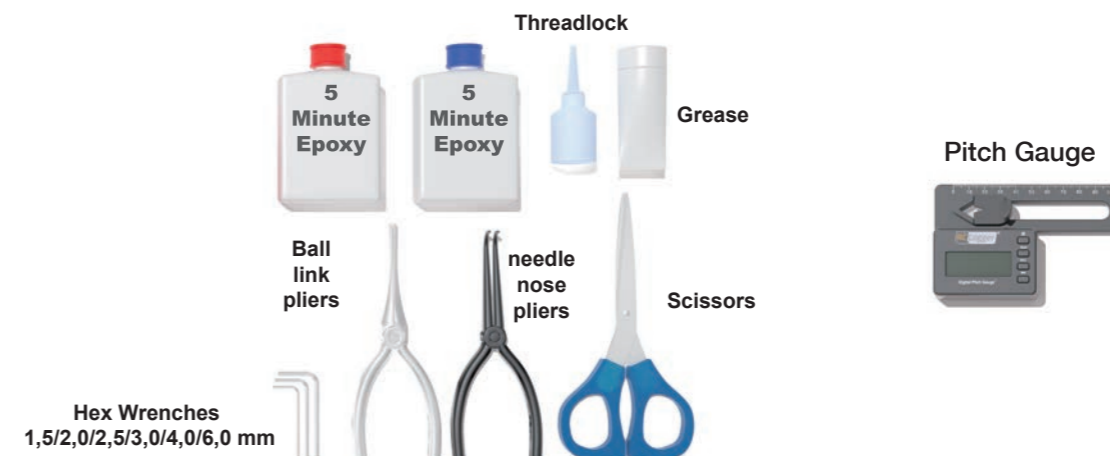

1 Chassis

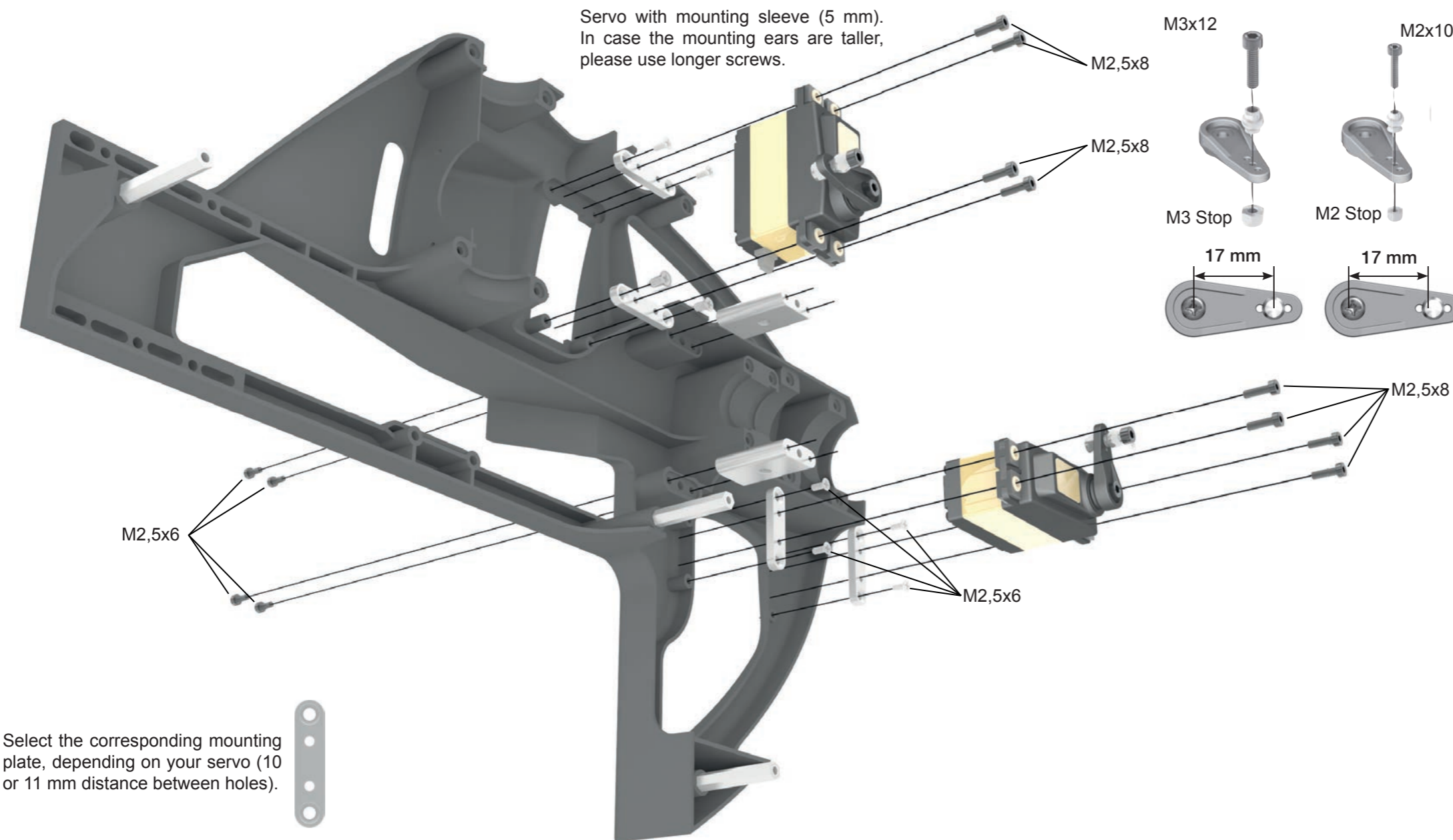

Select the corresponding mounting plate, depending on your servo (10 or 11 mm distance between holes).

Bag 1+3		
8x		M2,5x6
4x		M2,5x6
10x		M2,5x8
1x		M3x12
1x		M2x10
1x		M3
1x		M2
1x		Ø6
1x		Ø4,8
2x		15x21x5
2x		M2,5
3x		5,5x59

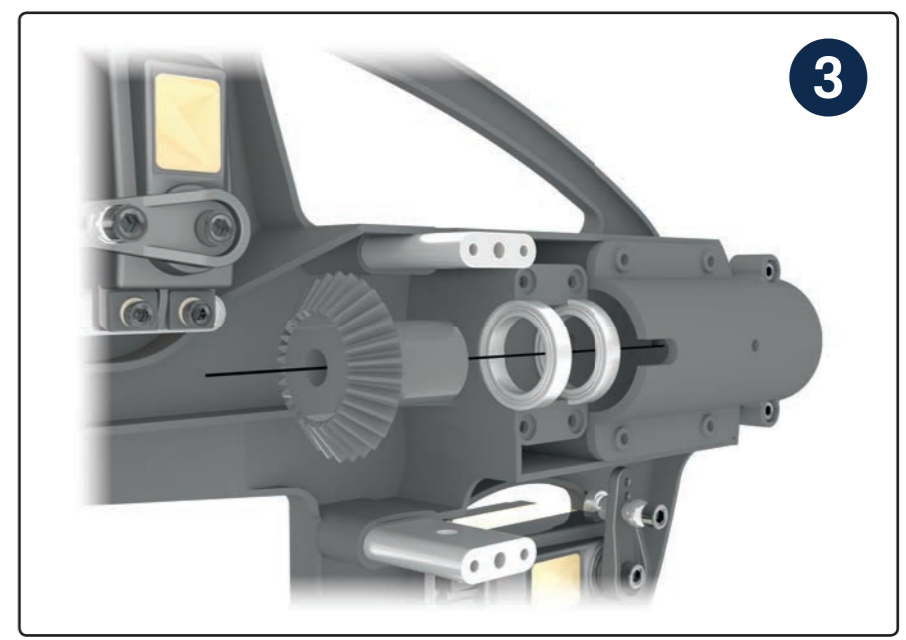
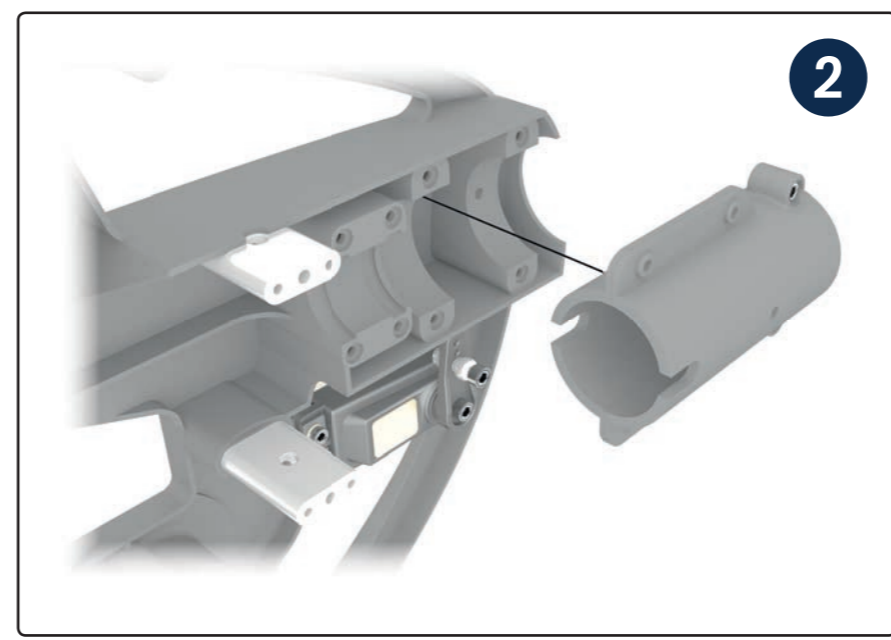
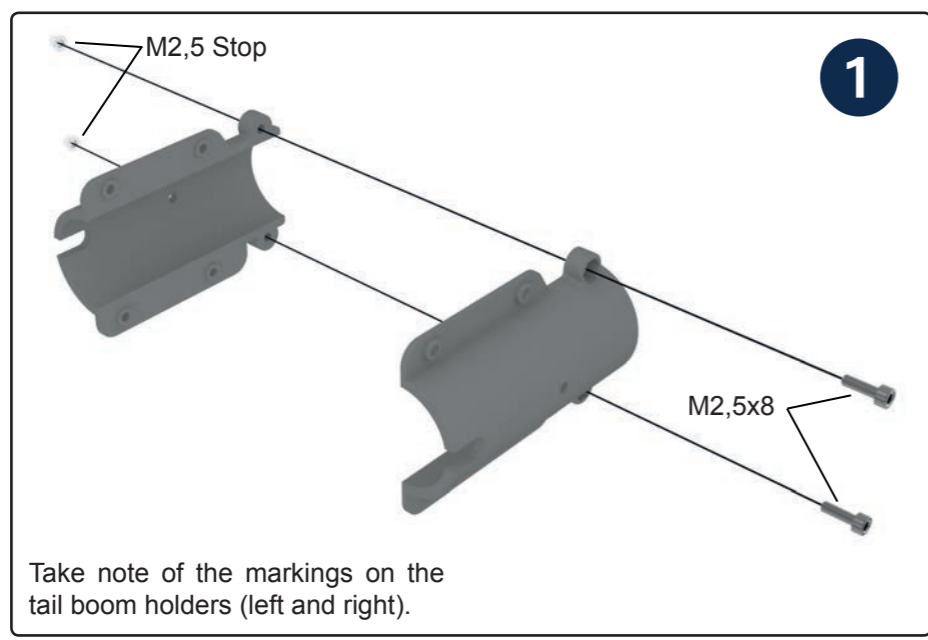







1 Chassis

1

M2,5 Stop

Use the 2.5 mm threaded rod to position the 2.5 mm hex lock nuts in the right hand side frame.

Bag 1

4x		M2,5x6
8x		M2,5x10
4x		M2,5x12
12x		M2,5
2x		14x21x6
1x		2,5x60

M2,5x6

M2,5x10

2

8x M2,5 Stop

M2,5x10

M2,5x12

1 Chassis and Landing Struts

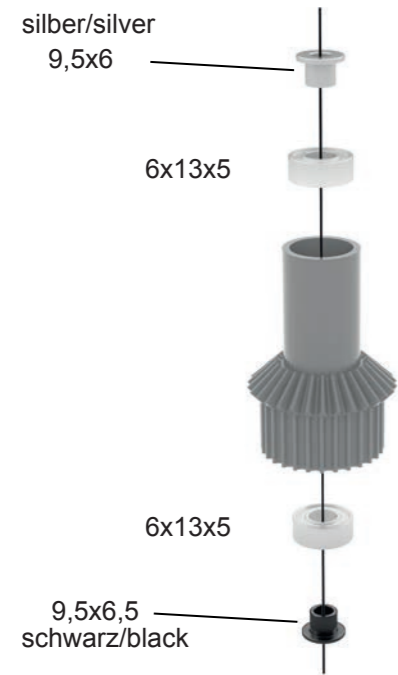

1

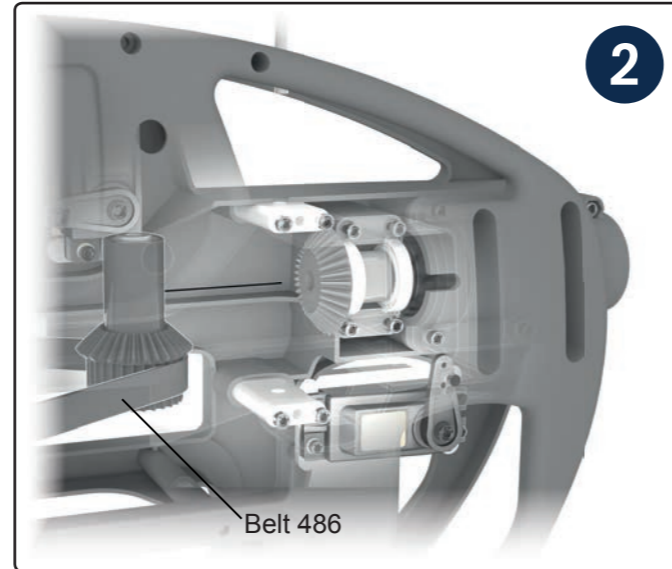

2

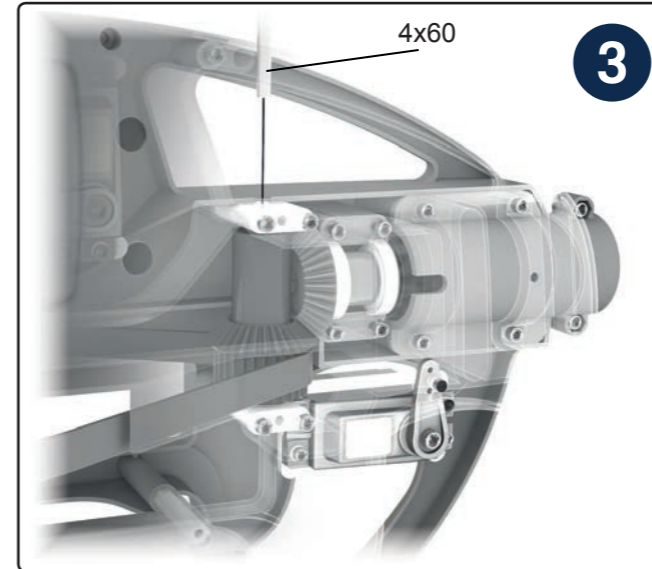

3

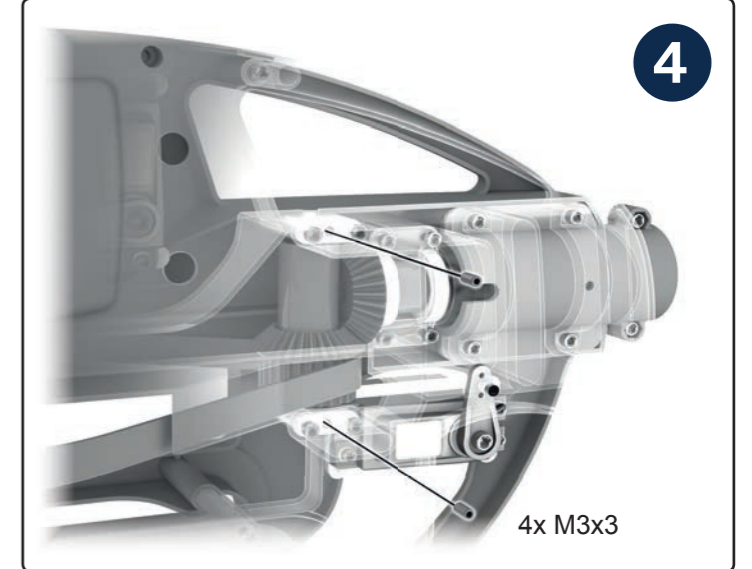

4

5

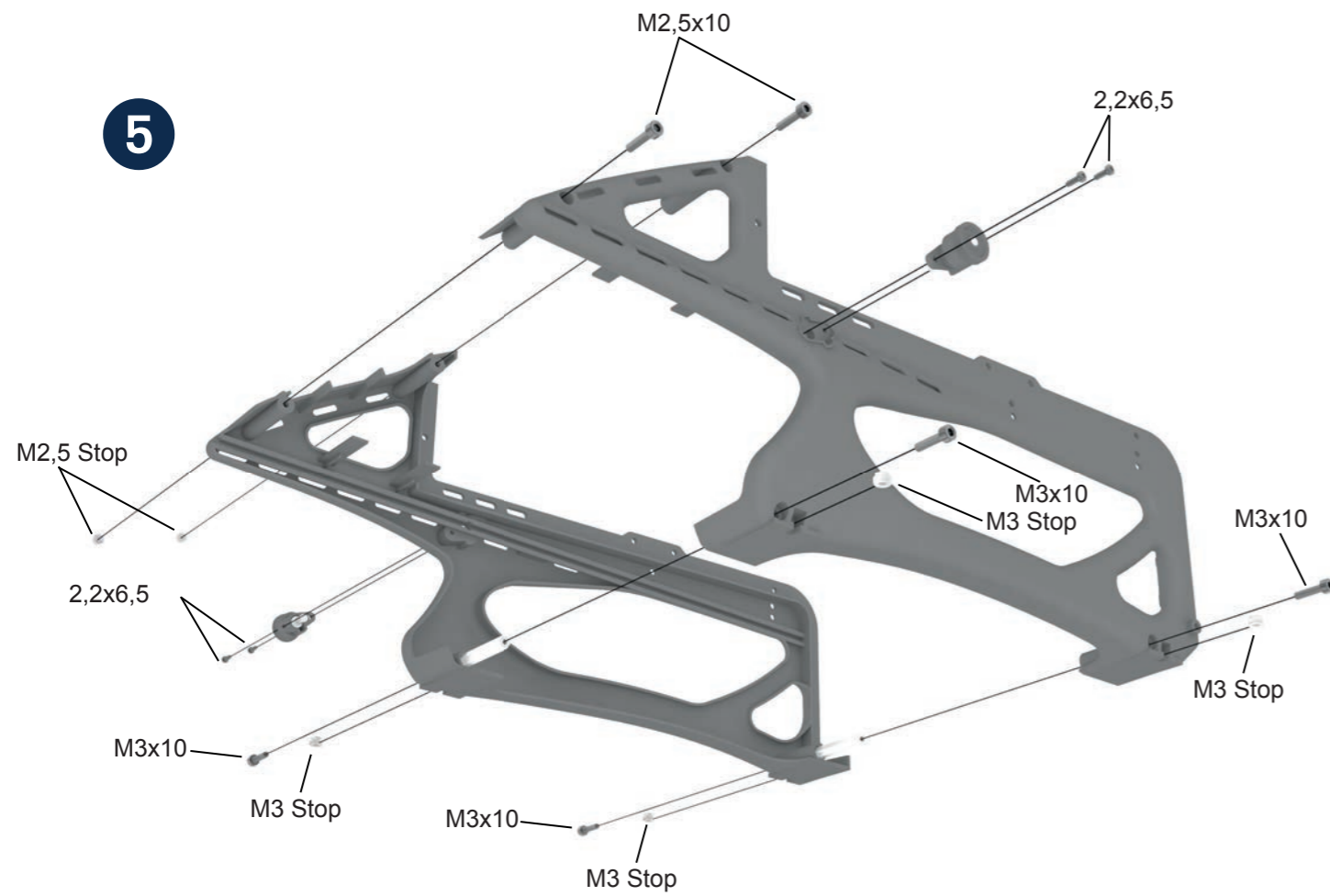

6

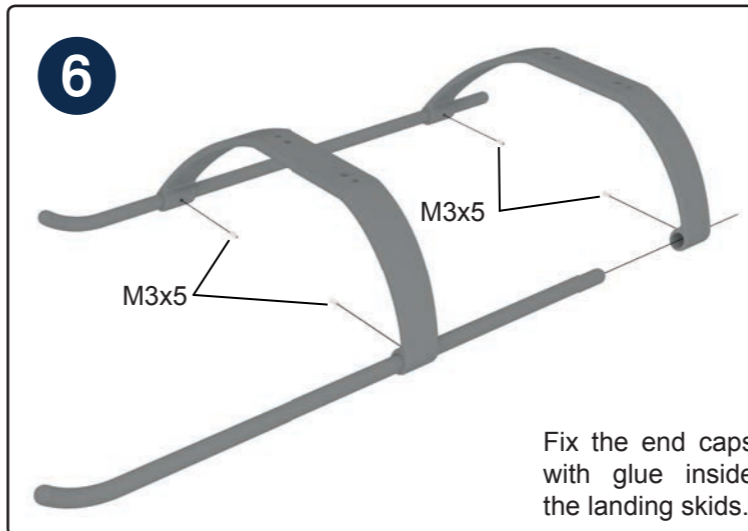

7

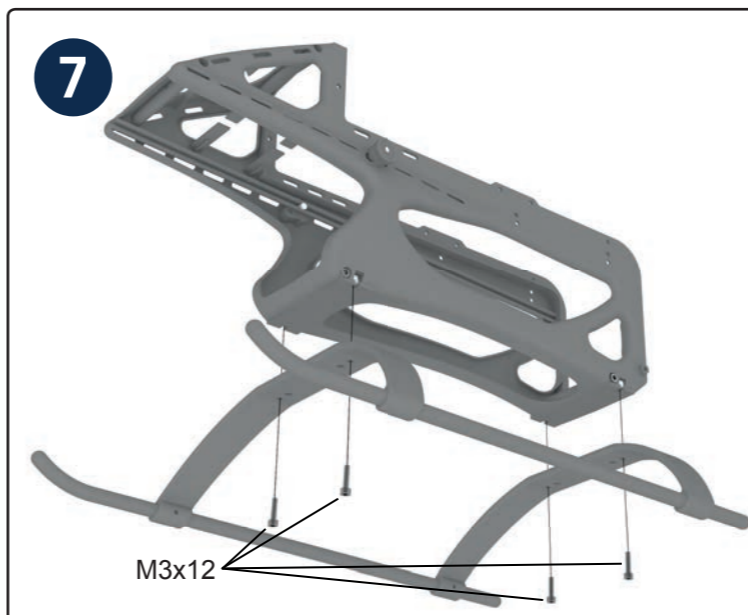

Bag 1+5

2x		M2,5x10
4x		M2,2x6,5
4x		M3x10
4x		M3x3
4x		M3x5
4x		M3x12
4x		M3
2x		M2,5
2x		6x13x5
1x		9,5x6
1x		9,5x6,5
2x		4x60
		5,5x59
1x		4x60

1 Chassis

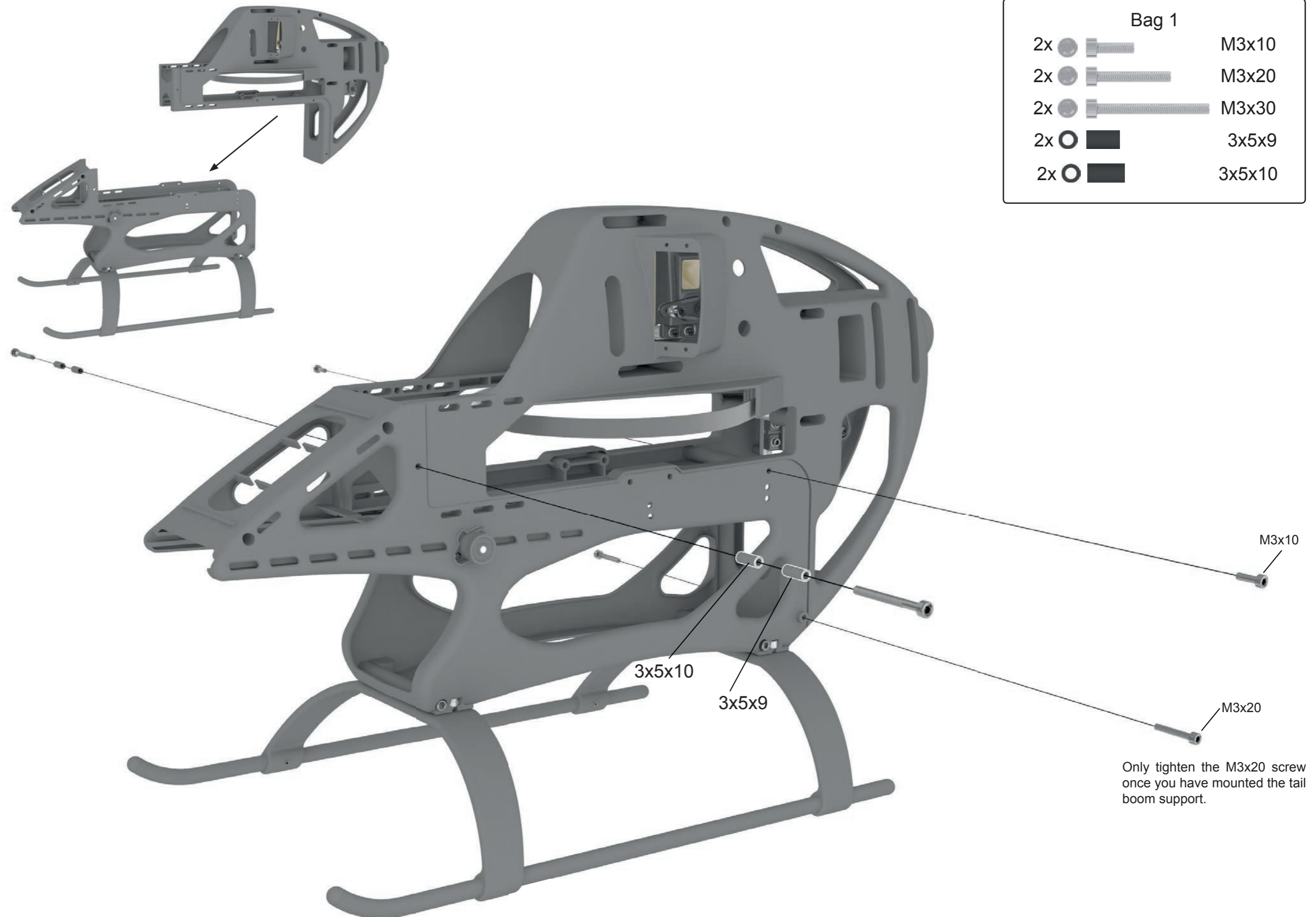

2 Servo Mounting

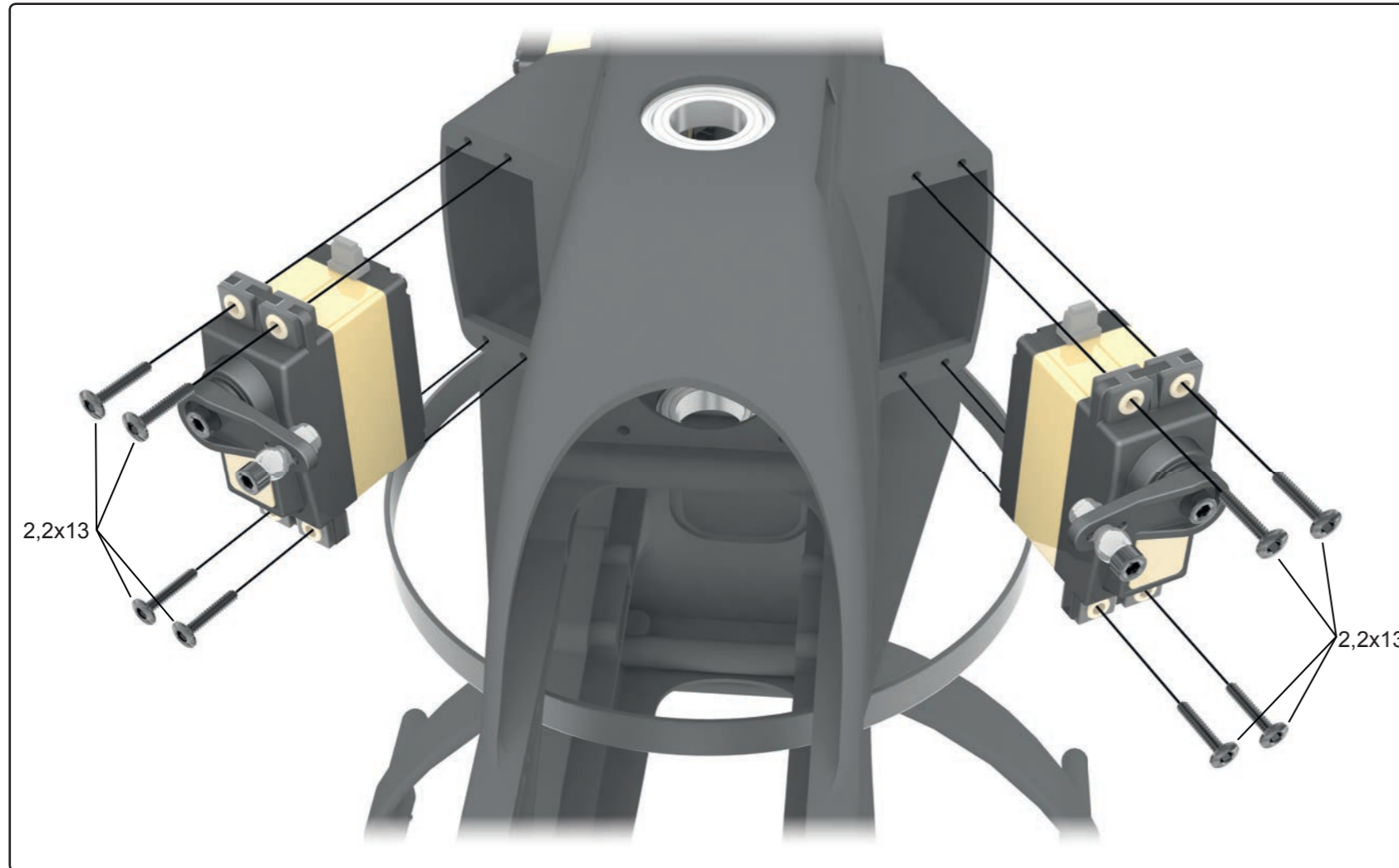

- Bag 3
- 8x M2,2x13
 - 2x M3x12
 - 2x Kugel/ball Ø6mm
 - 2x M3

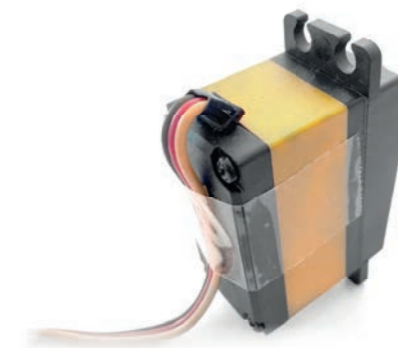

Roll links/ Aileron left
 Fix servo wire to the bottom side of the servo casing using electrical tape or scotch tape.

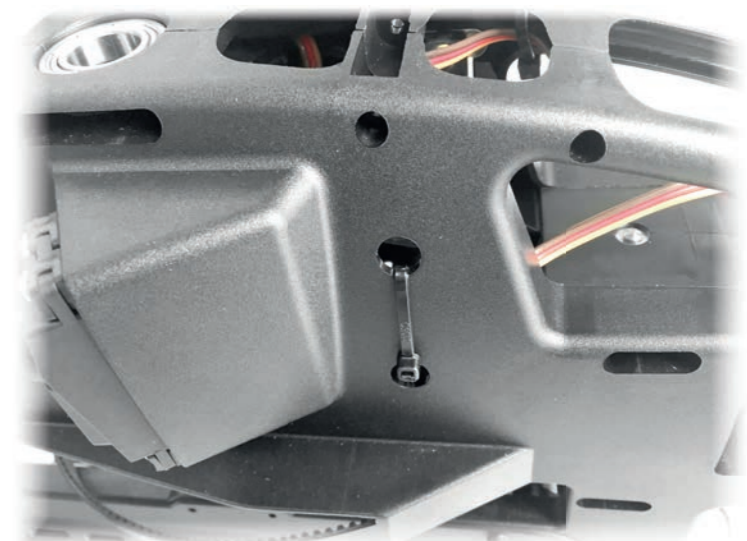
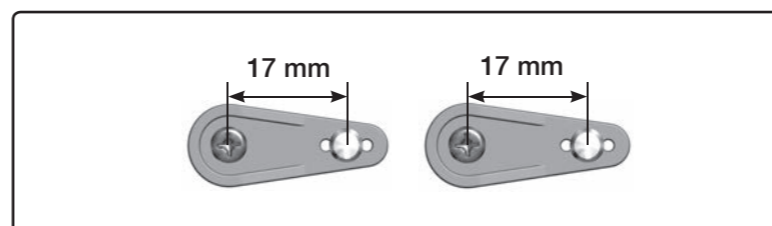
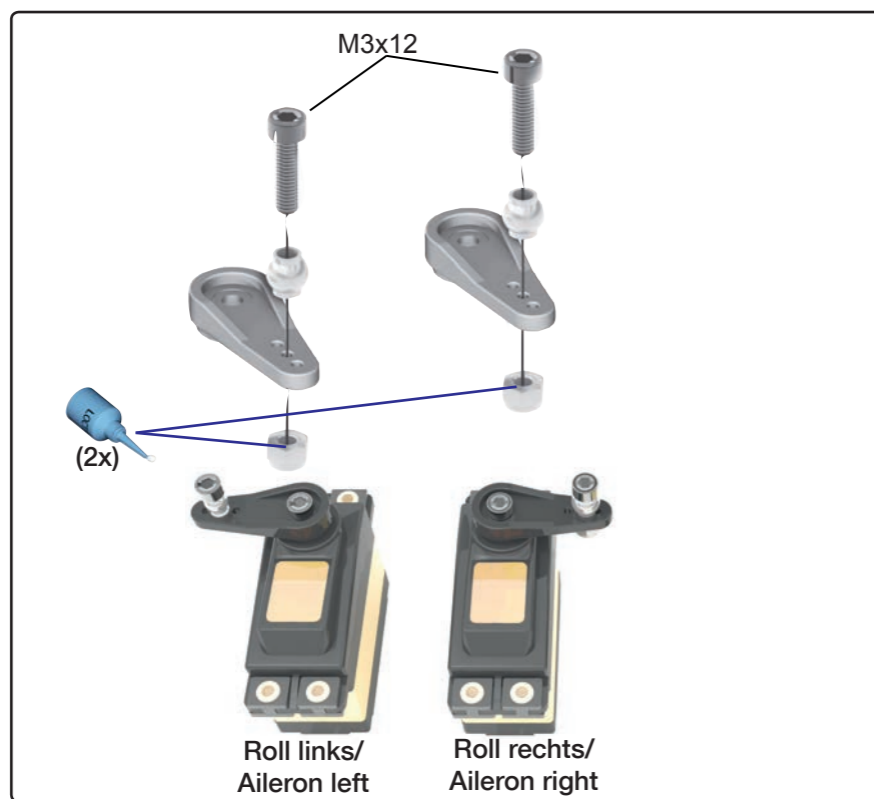

3 Main Gear

1

Prior to mounting the main gear, apply grease to both bevel gears in the tail drive.

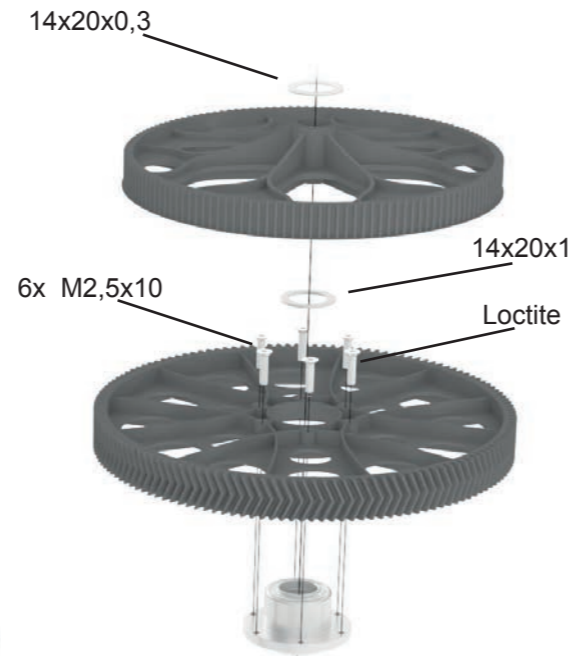

Apply grease to the one way bearing.

2



3



When mounted properly, the main gear has approx. 1 mm axial play.

Bag 4		
6x		M2,5x10
1x		M3x10
4x		M2,5x25
1x		4x20
1x		14x20x1
1x		14x20x0,3

Use the silicone tube provided as a flexible extension, to easily mount the 4x20 mm bolt in the tail gear.

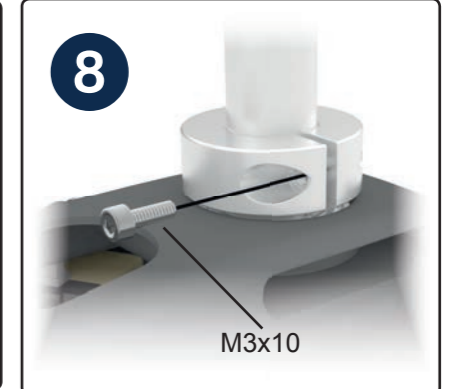
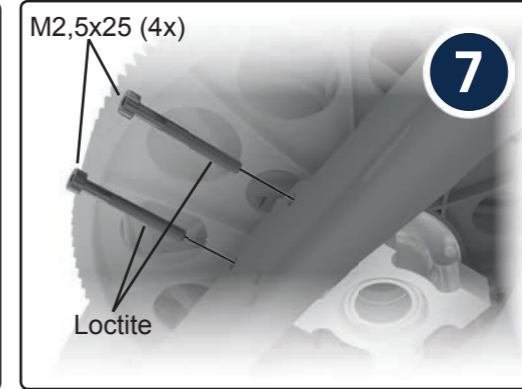
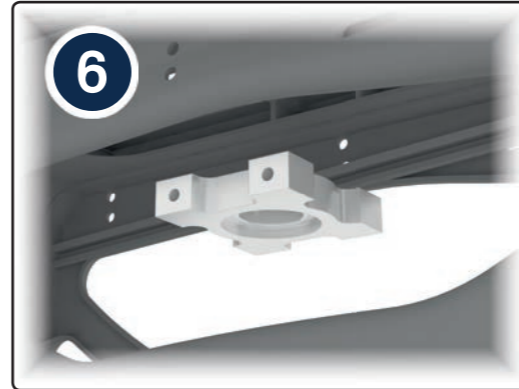
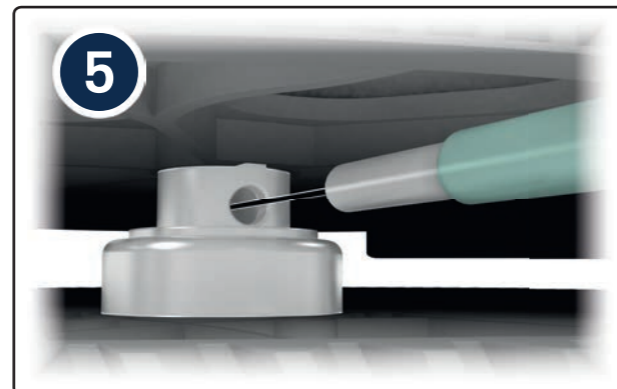
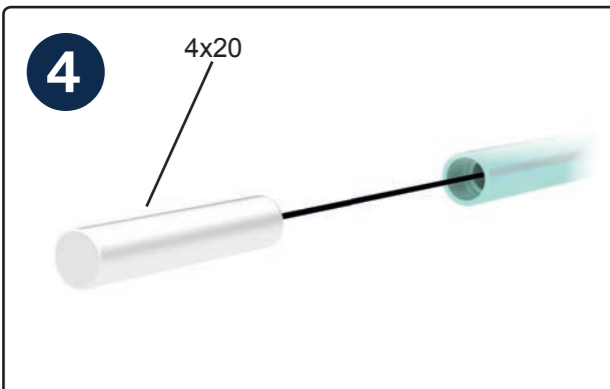

4 Motor Installation

1

M3x10

a

b

M4x20 (x4)

c

d

M3x10

2

3

5x M3x16

5x M3x16

4

Bag 6

4x	●	▬	M3x10
10x	●	▬	M3x16

Mounting the pinion:

- 1) position the pinion on the motor shaft so the grub screw sits in the flat spot on the motor shaft.
- 2) Push motor and pinion against the main gear. The herring bone gear helps with the proper alignment of pinion and main gear.
- 3) There must be next to no backlash between main gear and pinion. Check the gear mesh after the first couple of flights.

5 Tail Rotor

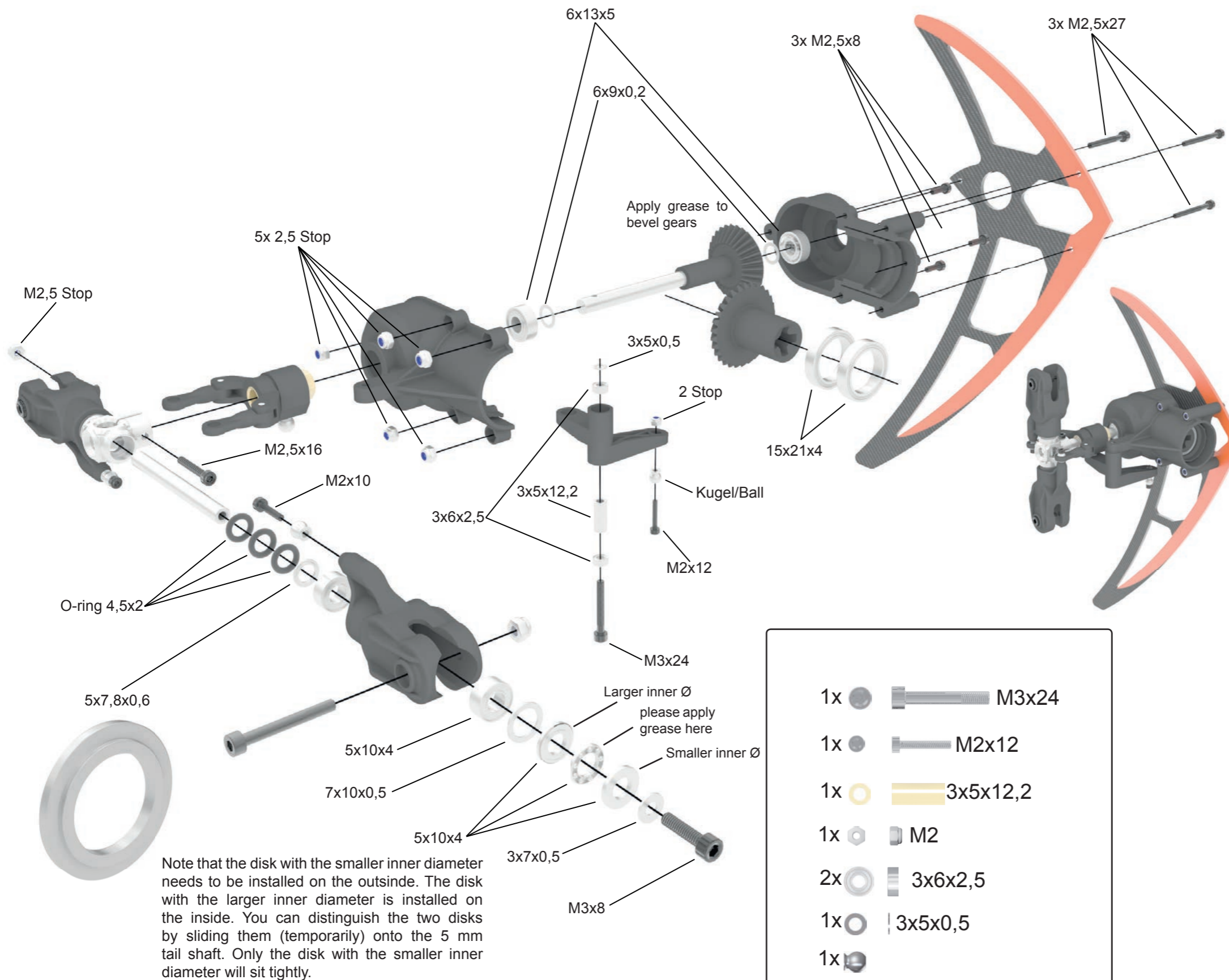

Note that the disk with the smaller inner diameter needs to be installed on the outside. The disk with the larger inner diameter is installed on the inside. You can distinguish the two disks by sliding them (temporarily) onto the 5 mm tail shaft. Only the disk with the smaller inner diameter will sit tightly.

- 1x M3x24
- 1x M2x12
- 1x 3x5x12,2
- 1x M2
- 2x 3x6x2,5
- 1x 3x5x0,5
- 1x

- Bag 7
- 2x 6x13x5
 - 2x 15x21x4
 - 3x M2,5x8
 - 3x M2,5x27
 - 1x M2,5x16
 - 2x M3x24
 - 2x M3
 - 6x M2,5
 - 2x 3x7x0,5
 - 2x 5x10x4
 - 4x 5x10x4
 - 6x 4,5x2
 - 2x 7x10x0,5
 - 2x 5x7,8x0,6
 - 2x
 - 1x M2x10
 - 2x 6x9x0,2

6 Torque Tube

1 Torque Tube assembly

Push the four ball bearing mounted plastic sleeves to the torque tube, use the 10 mm adhesive shrink tubing to hold the bearings in position.

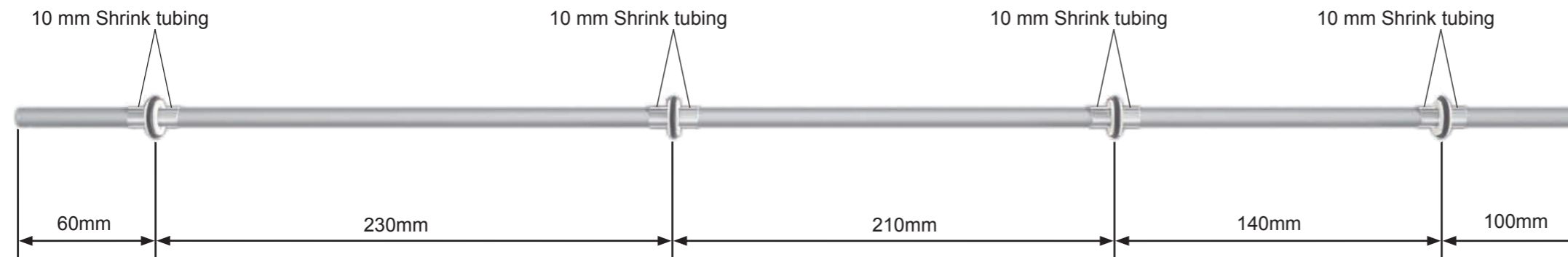

Bag 8 + 12	
2x	M3x16
2x	M3
2x	3mm
2x	M3x16

2

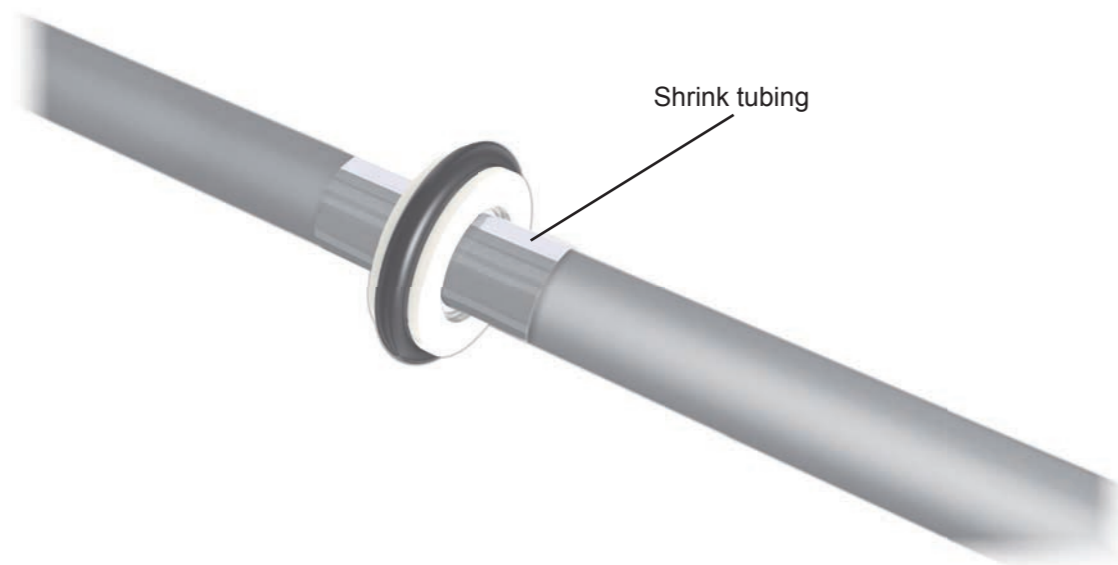

3



Please ensure prior to inserting the torque tube that the tail boom is dirt-free inside. If necessary clean it with a cloth.

Please apply a good amount of grease to the rubber o-rings and to the inside of the tail boom before inserting the torque tube assembly into the tail boom.

4

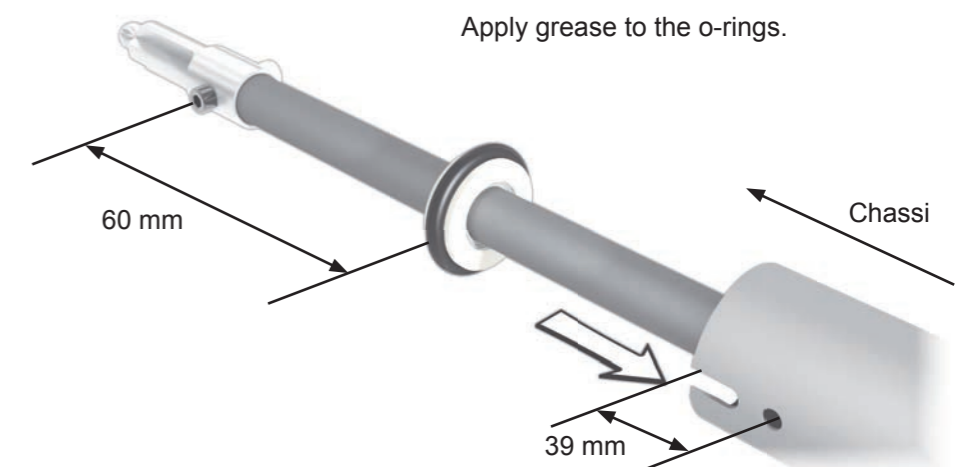

5 Carbon tail rotor push rod

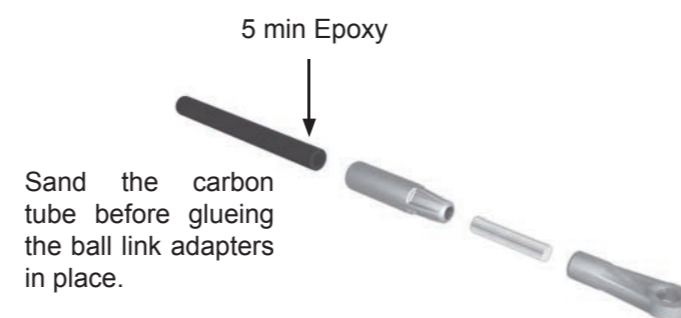

7 Tail Boom Mounting

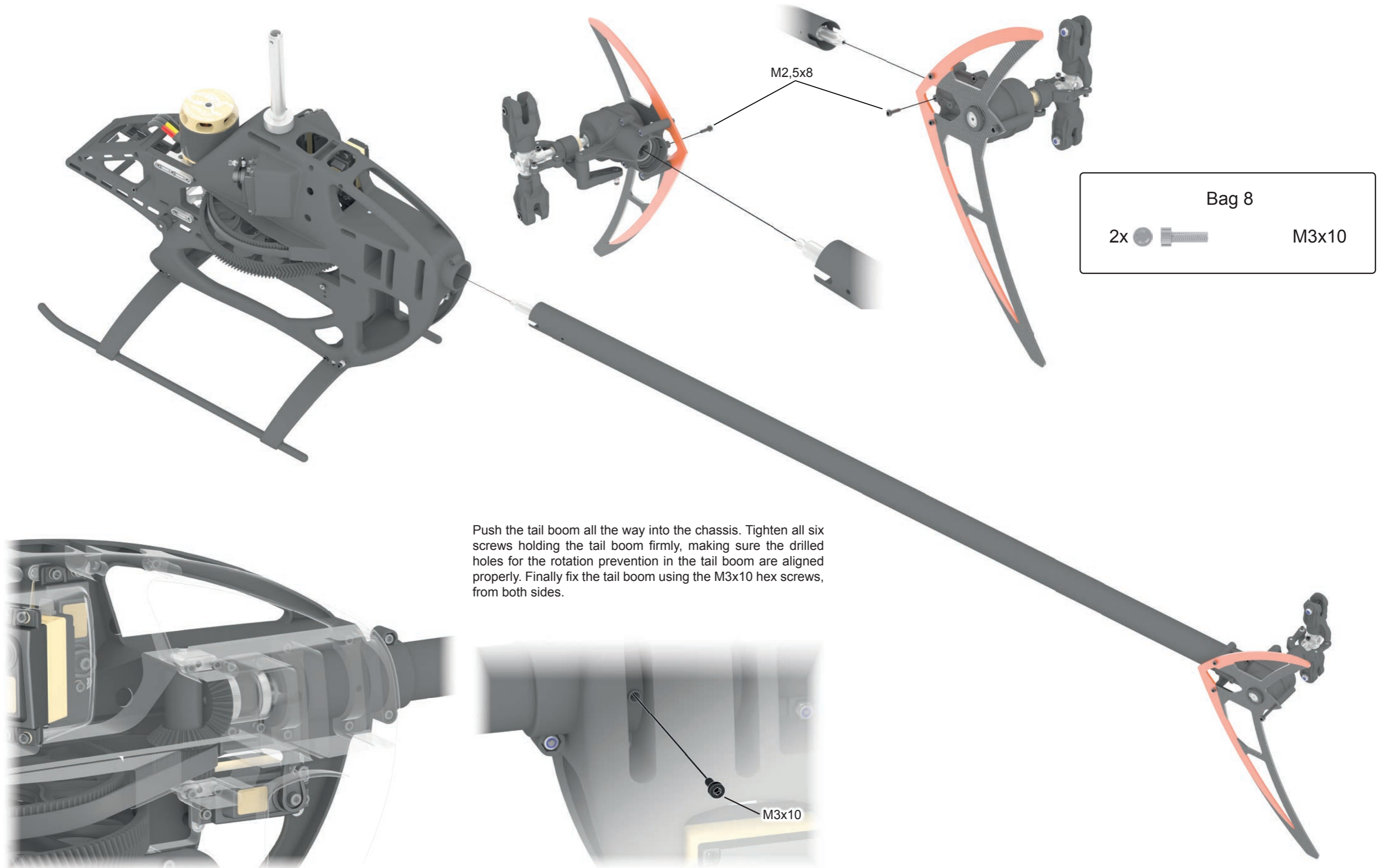

8 Tail Boom Brace

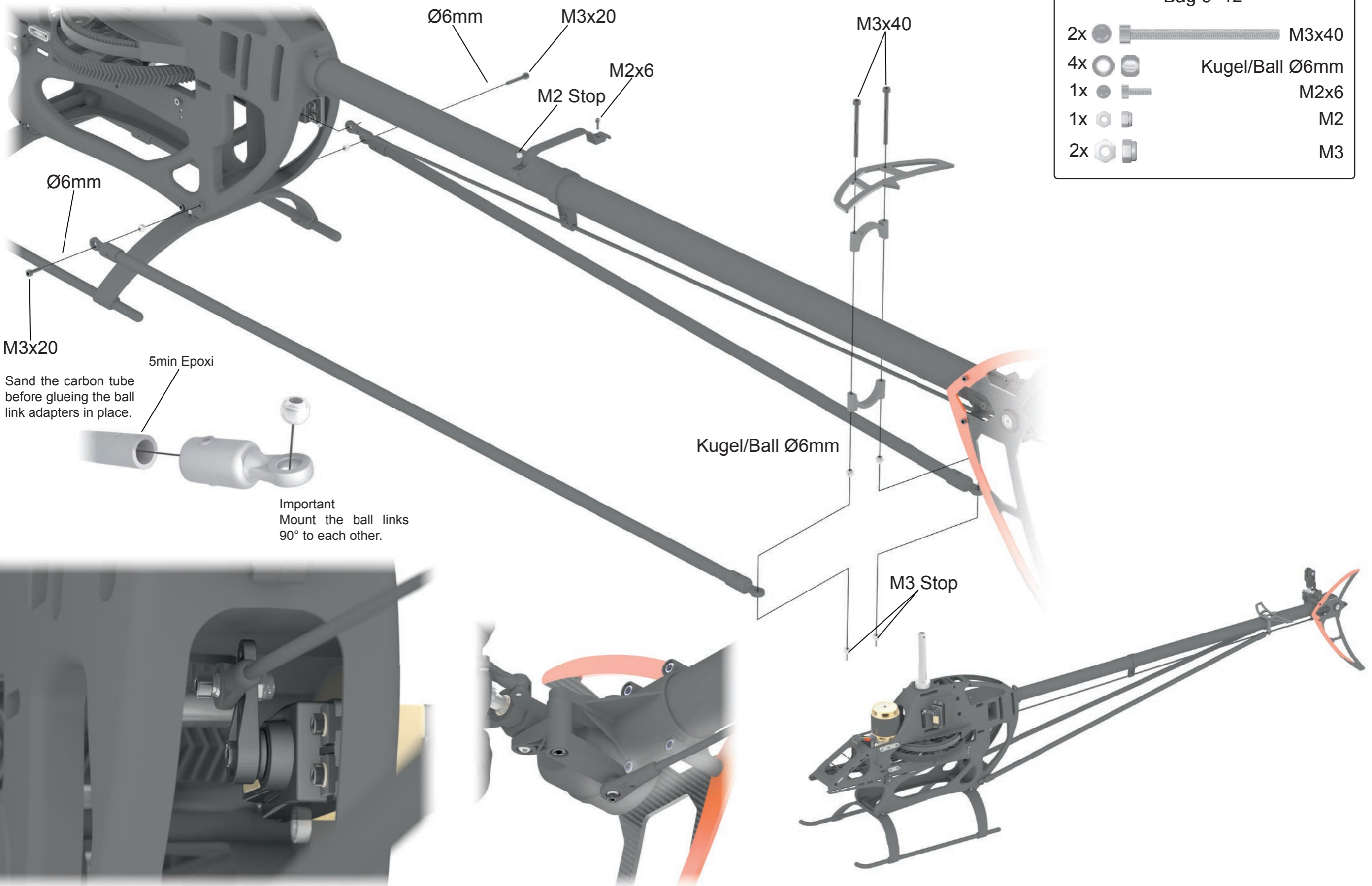

9 Swashplate

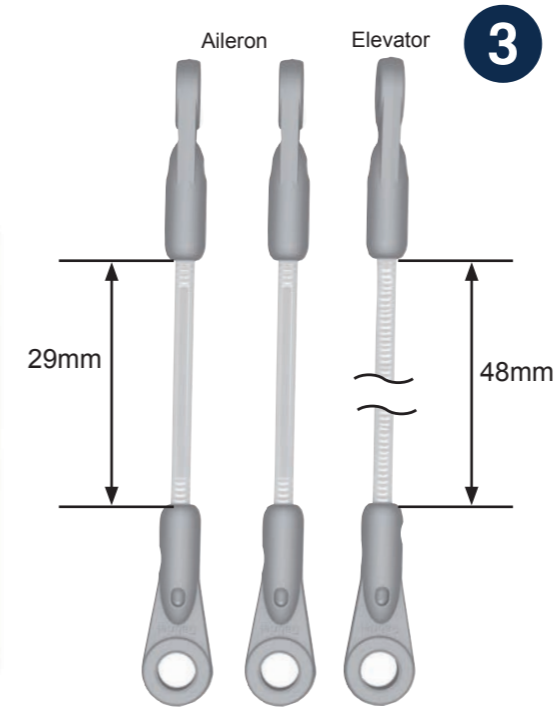
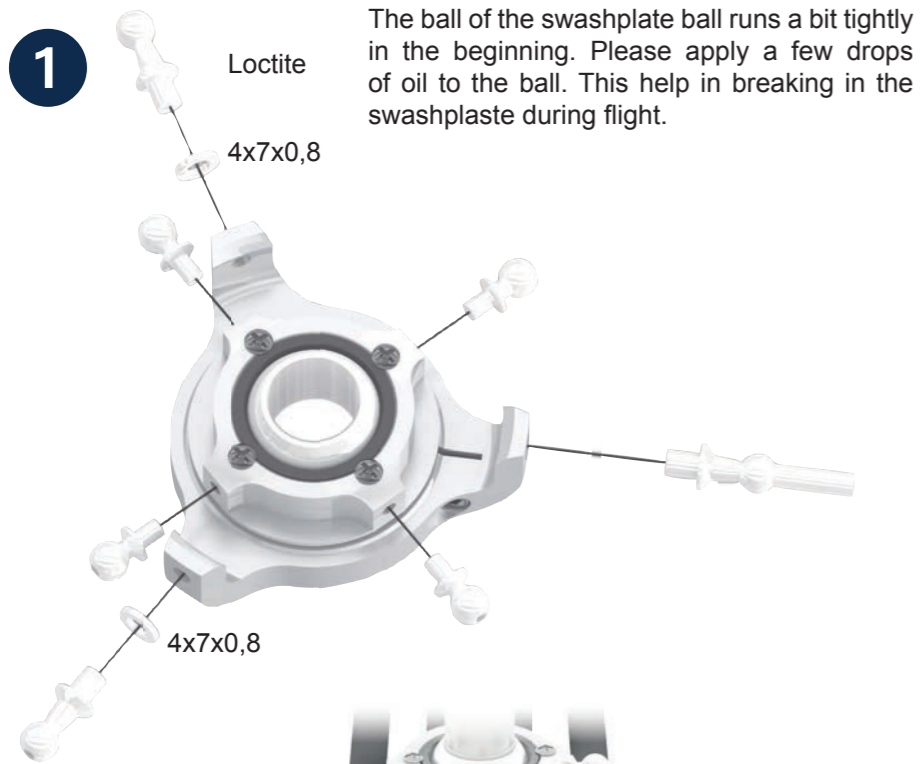

Bag 9

5x			M2,5x6
2x			4x7x1
6x			
2x			3x5x9
2x			

Note when mounting the ball links: One side of the ball link will clip on easily. The other one is too tight to clip on easily. The brand name Gabriel must point outwards.

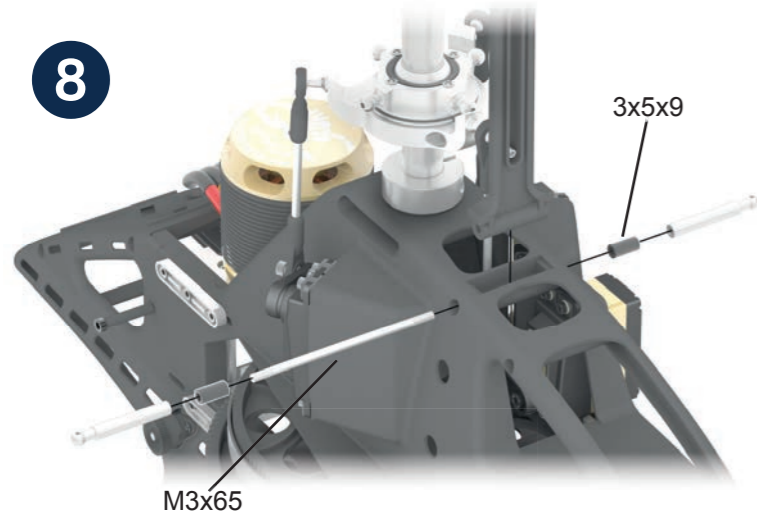
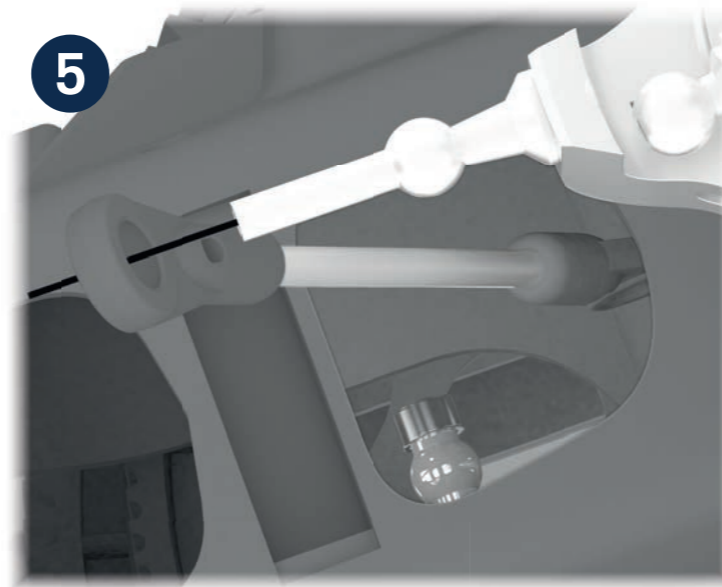
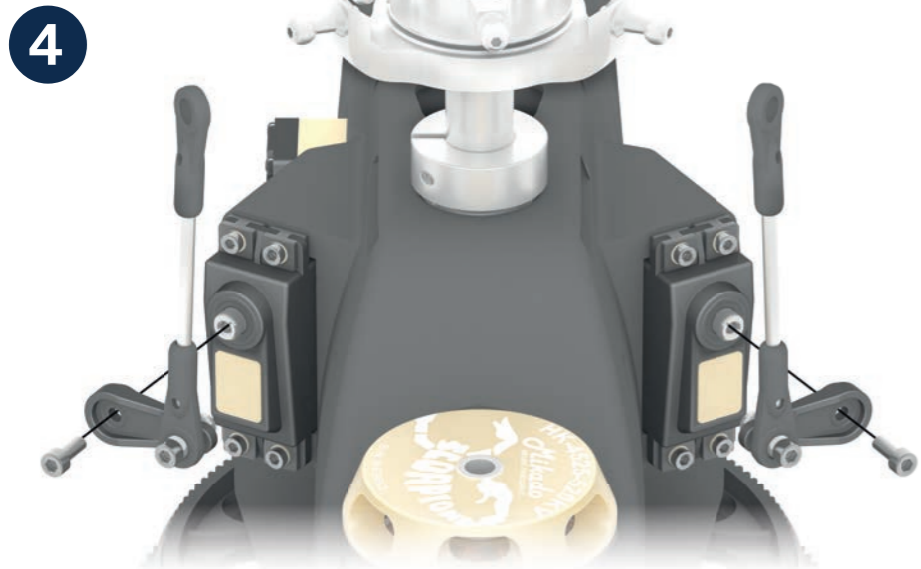

10 Rotor Head

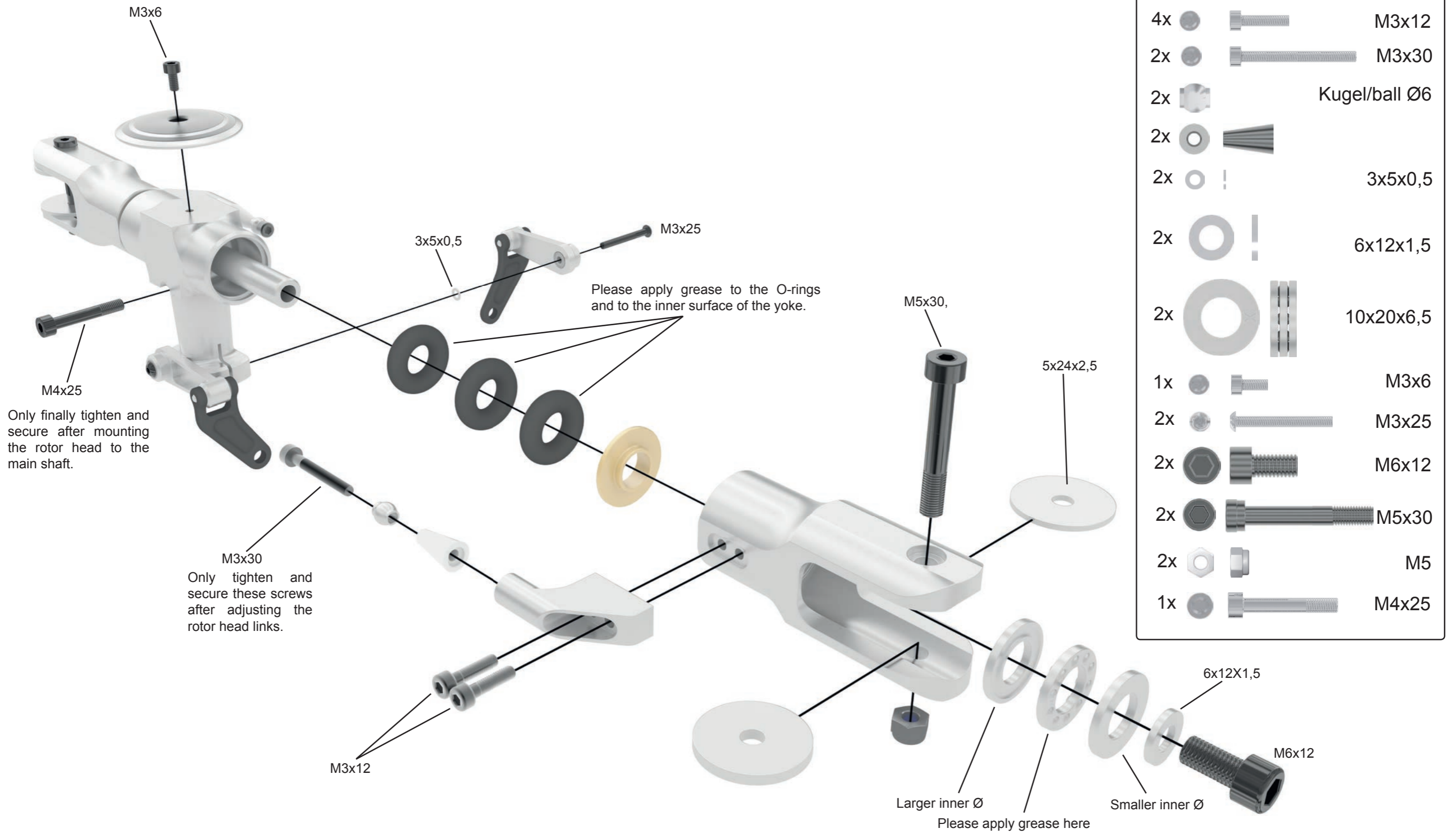

11 Rotor Head Linkage

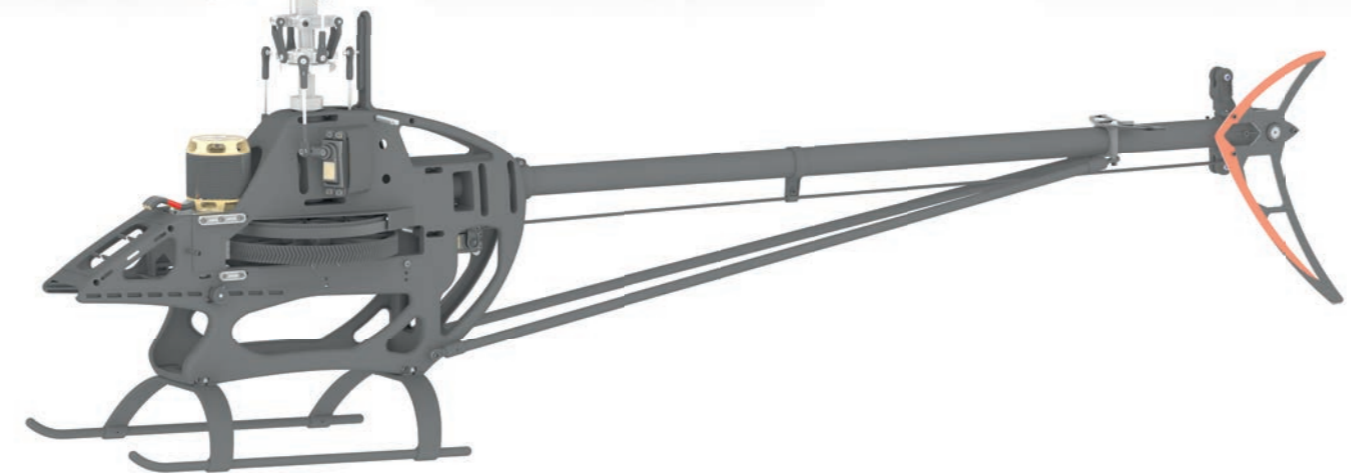
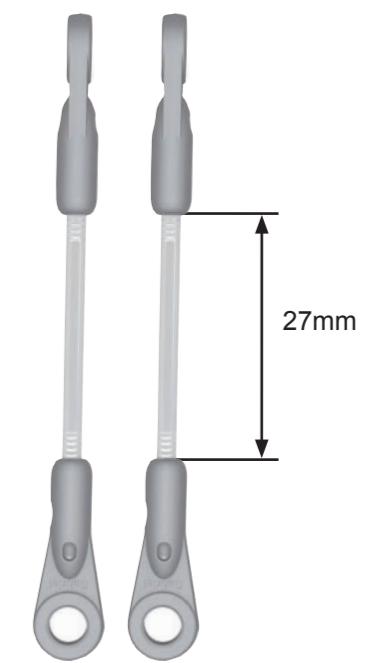
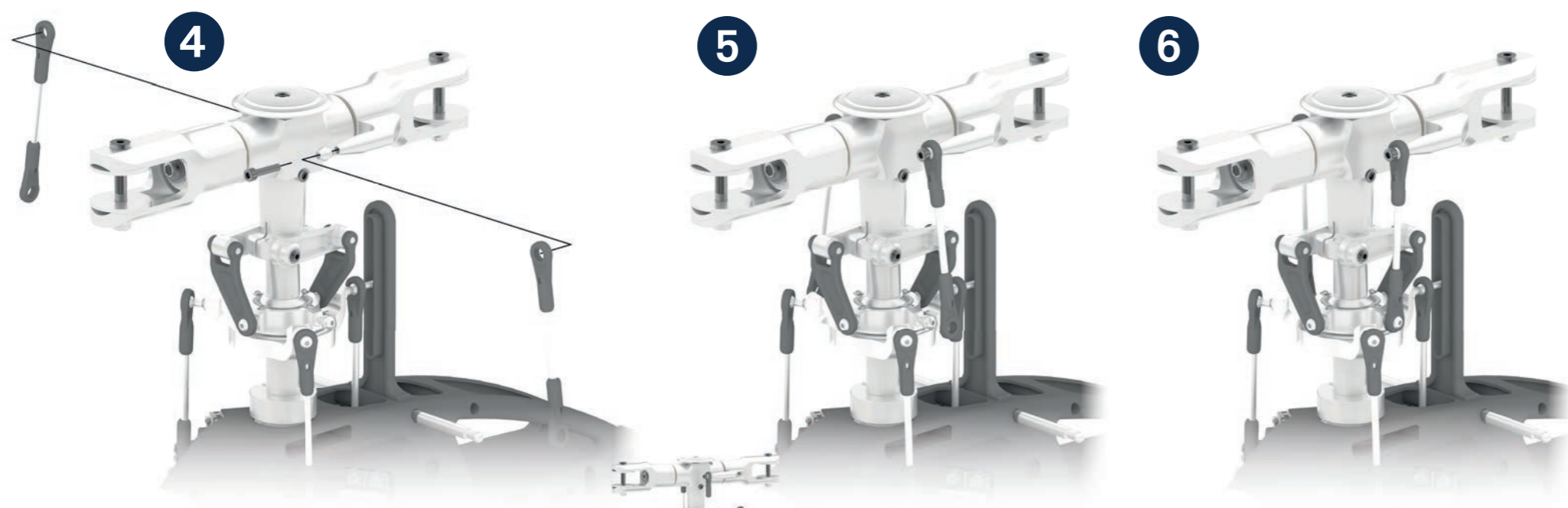
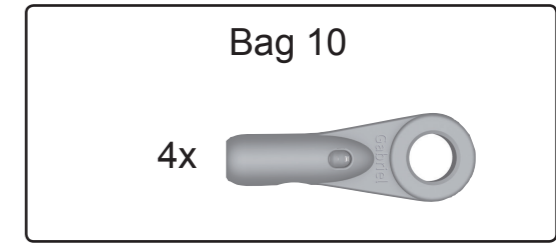

Note when mounting the ball links: One side of the ball link will clip on easily. The other one is too tight to clip on easily. The brand name Gabriel must point outwards.

Tighten and secure the M4x25 screw in the main rotor head, the M3x30 in the blade holders and the M3x25 in the swash plate driver after mounting and adjusting the rotor head and the linkages.

12 Wiring RC Components

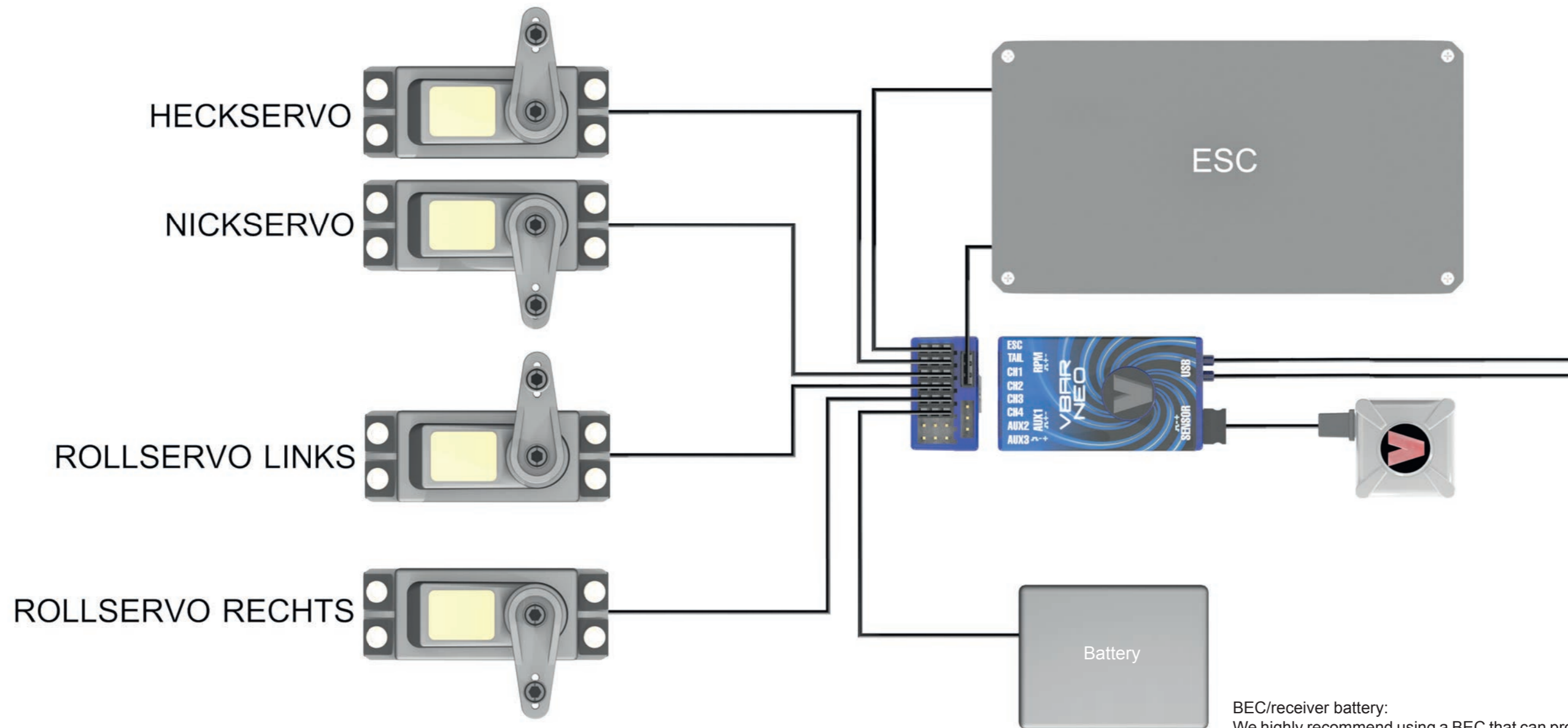

BEC/receiver battery:
We highly recommend using a BEC that can provide two power leads to the Receiver/RC Components.

Wiring:
Please note: All wires must be placed in such a way that they cannot be damaged by any sharp edges during operation of the helicopter. Please apply the fabric tube and the edge guard provided in this kit. Both types of protection are also available individually from Mikado.

13 Mounting ESC/ Battery

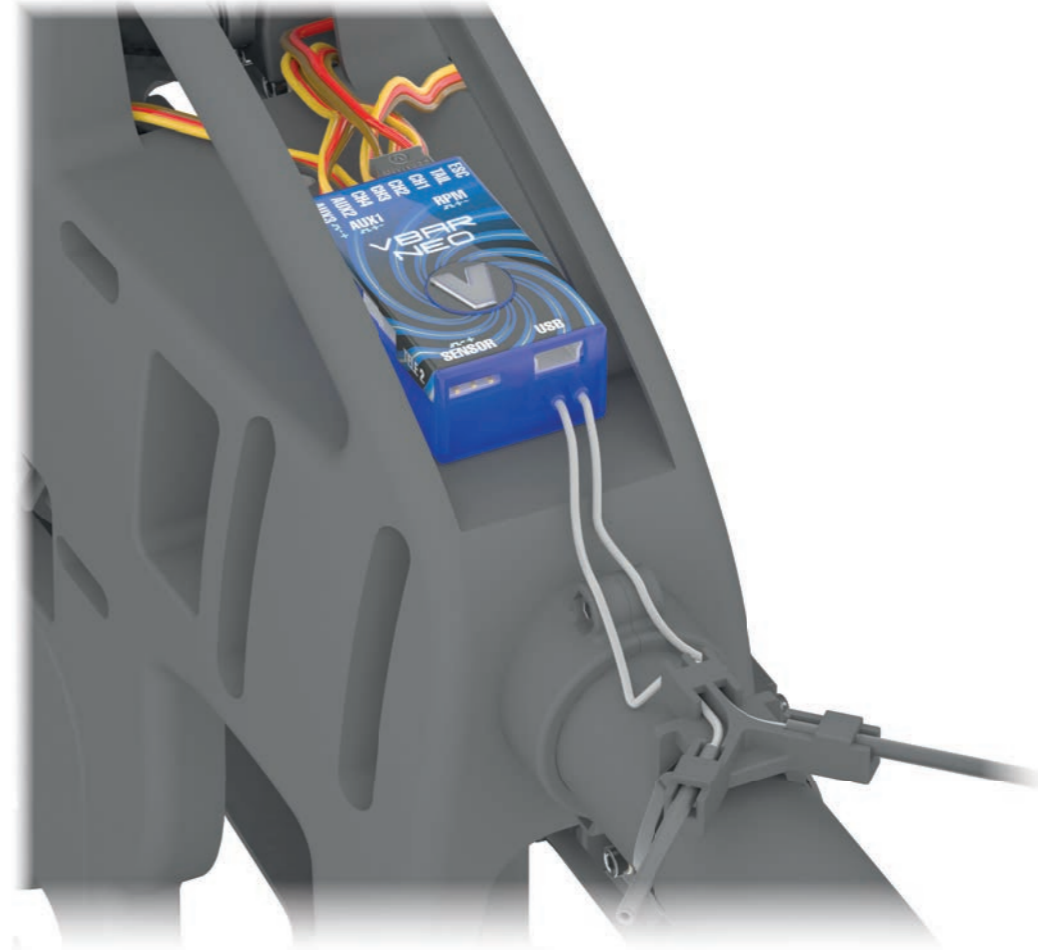
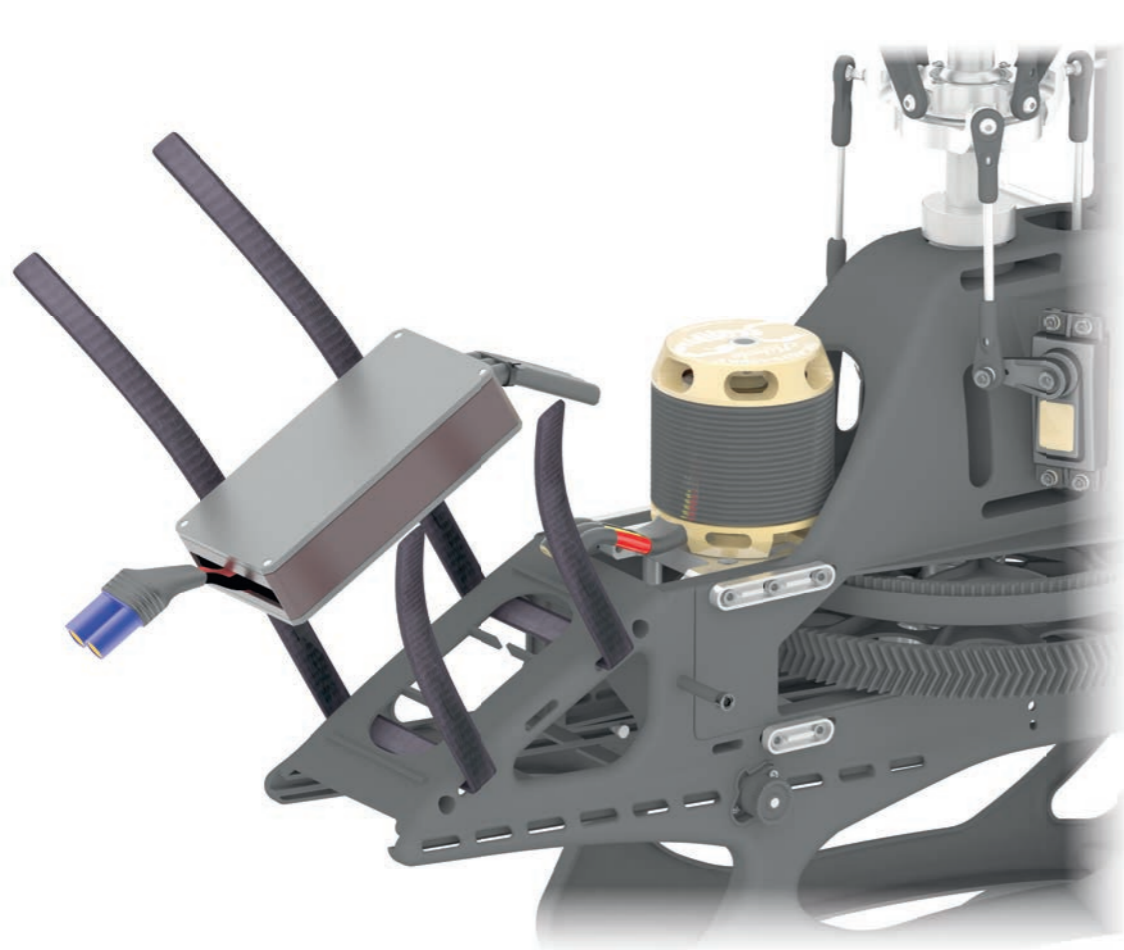

1

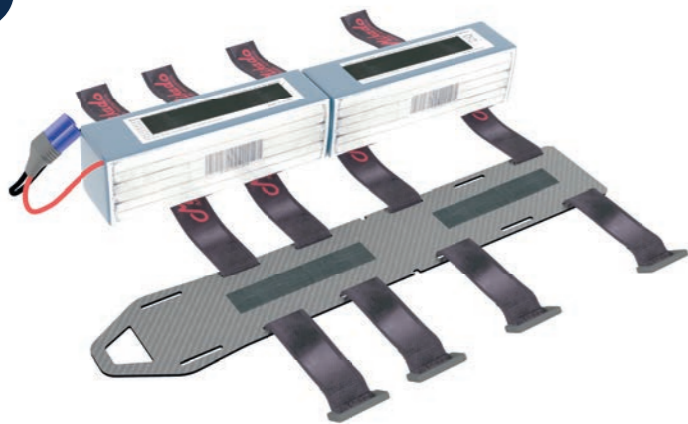

2



3

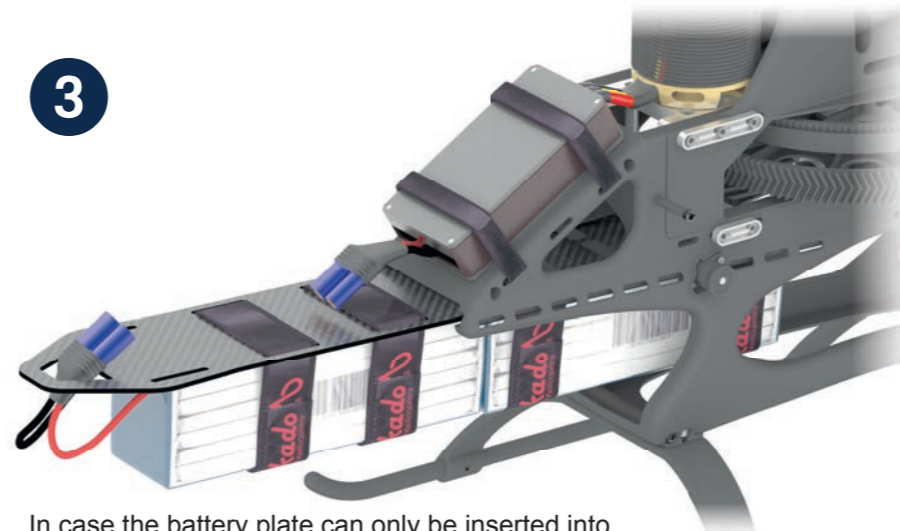

In case the battery plate can only be inserted into the chassis with difficulty in the beginning, please apply a small amount of silicone oil at the edges.



Before each flight make sure that the battery plate is secured with both quick release mechanisms.

14 Canopy and Overview

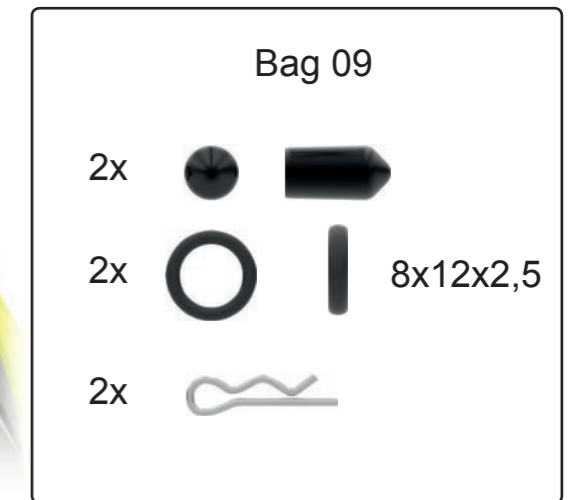
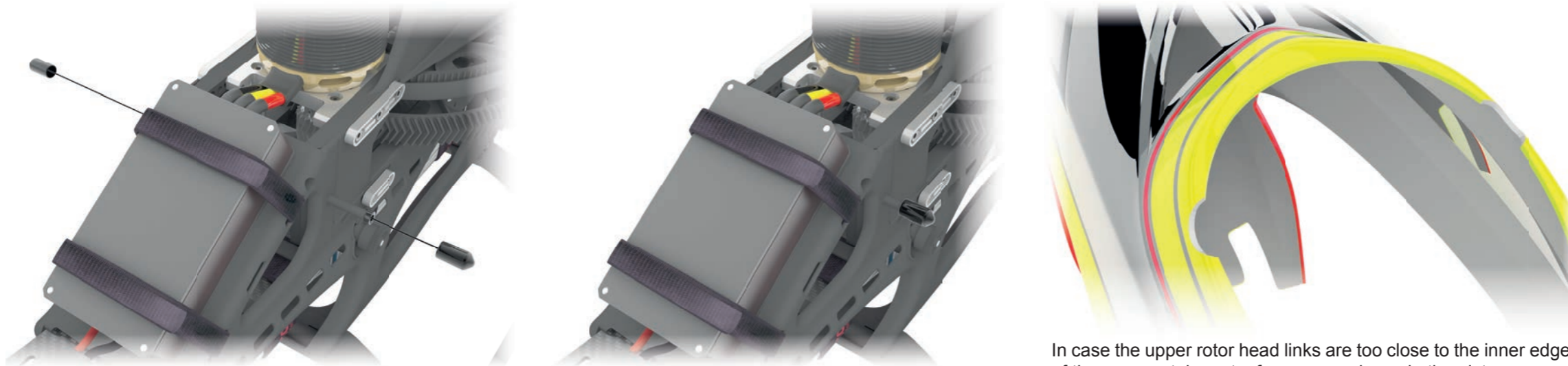

In case the upper rotor head links are too close to the inner edges of the canopy, take out a few mm as shown in the picture.

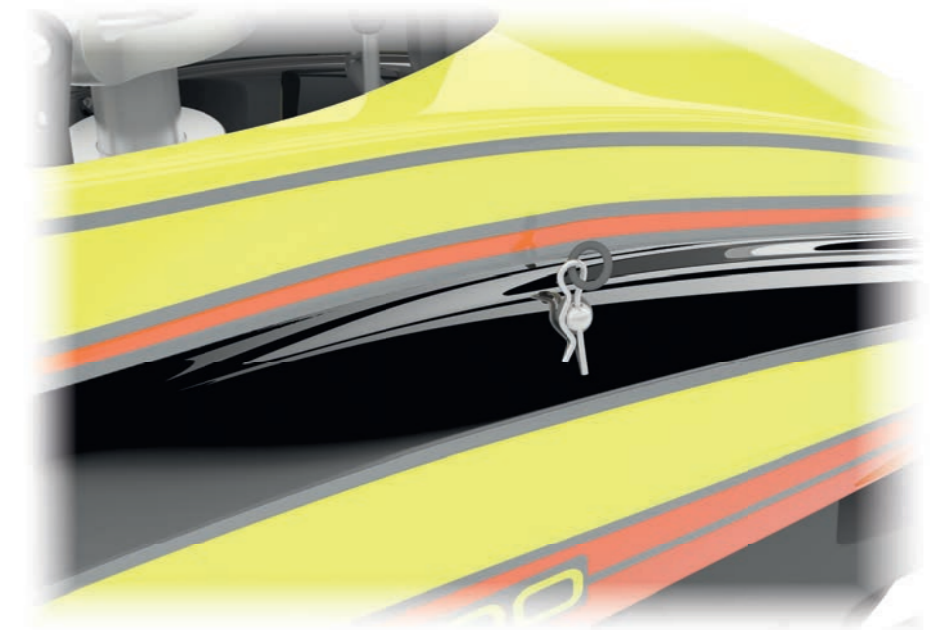
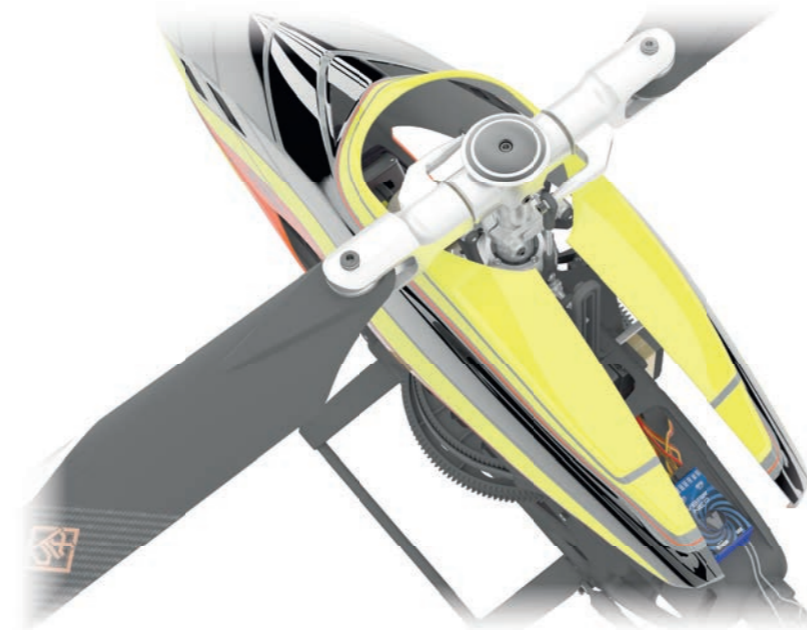

The canopy of the LOGO 700 is mounted via four attachment points. The two attachment points in the front ensure that the canopy sits well on the chassis during flight. have a guiding function. In the back, the canopy is attached by two rubber grommets. You will find another, high-quality, set of rubber grommets included in the kit. You may use these, if desired.

Important note: A special feature of the Logo 700 canopy ist that it the back part is fully closed. This back area is connected via two pins and magnets. Take your time when mounting and dismounting the canopy. Use proper care when sliding the canopy over the rotor shaft.

Before each flight, check that the canopy sits securely. If the canopy sits too lose, this can deteriorate the flight performance of the helicopter. If the canopy becomes lose during flight the helicopter will crash.

This canopy is 100% hand-made. Small irregularities in the surface, the airbrush design or color are normal. They do not constitute a reason for complaint



Please mount here the edge protector strip (included in the kit) and fix it with speed glue.



15 Overview Spare Parts Mainframe

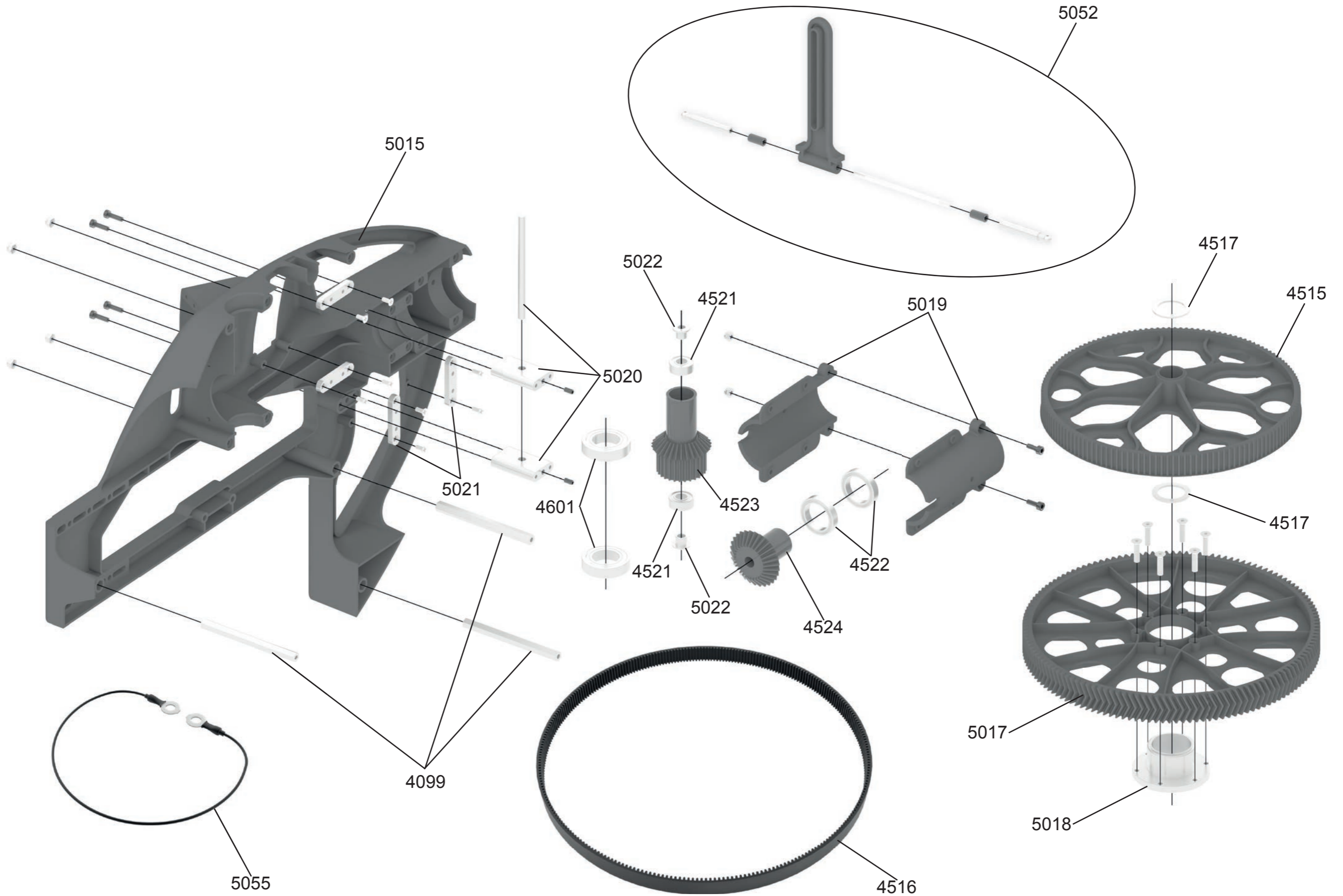

15 Overview Spare Parts Mainframe

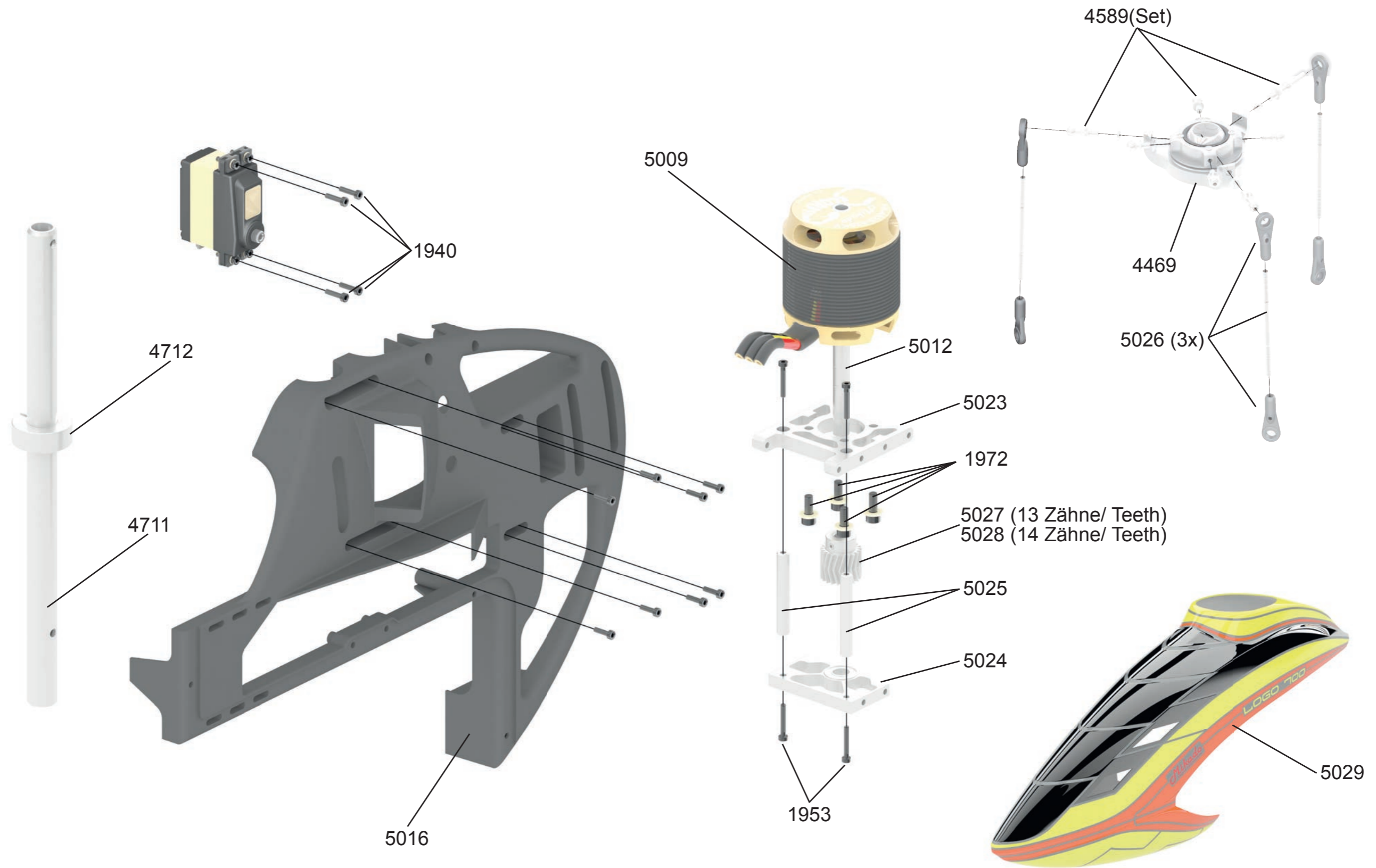

15 Overview Spare Parts Mainframe

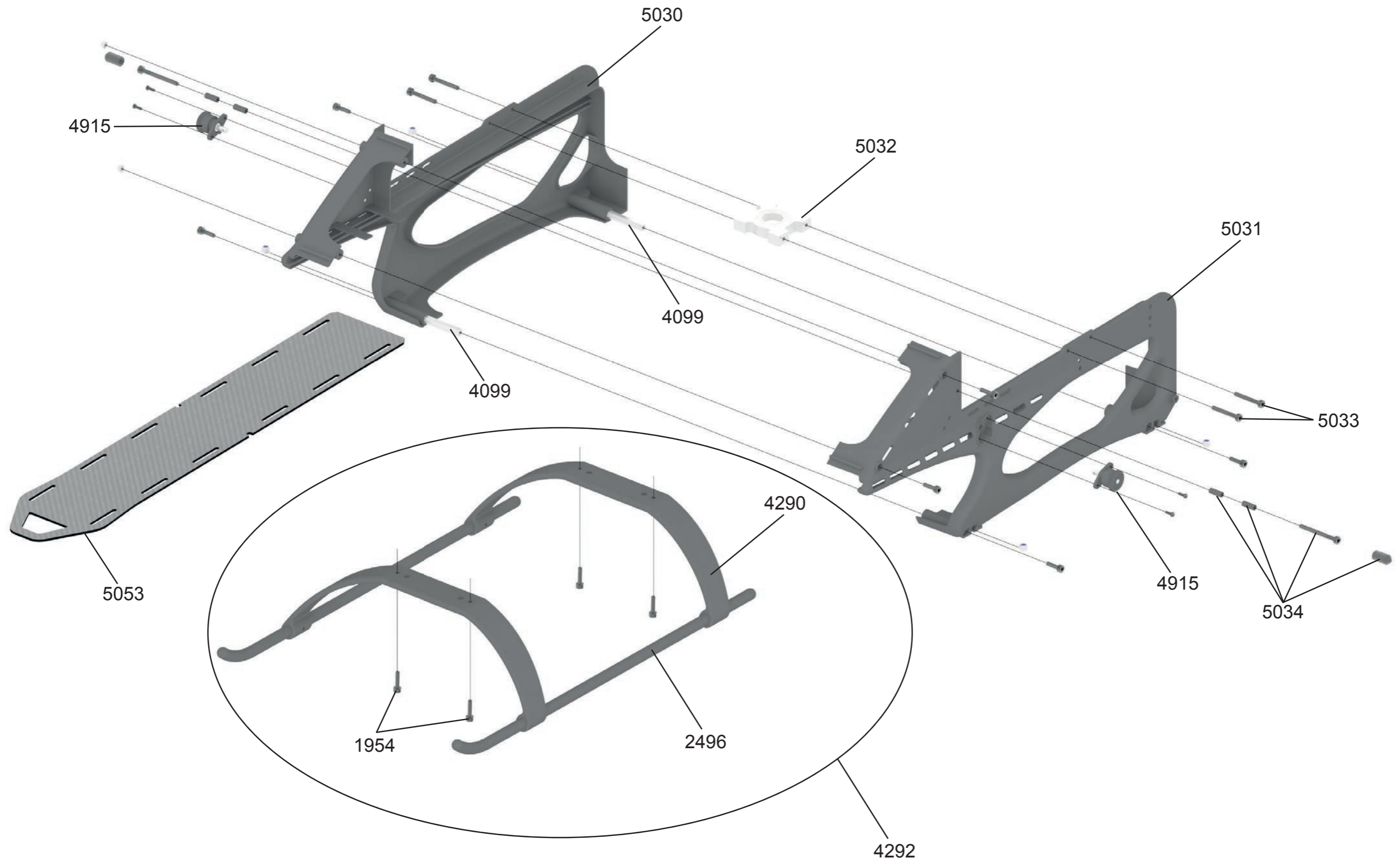

16 Overview Spare Parts Tail Boom

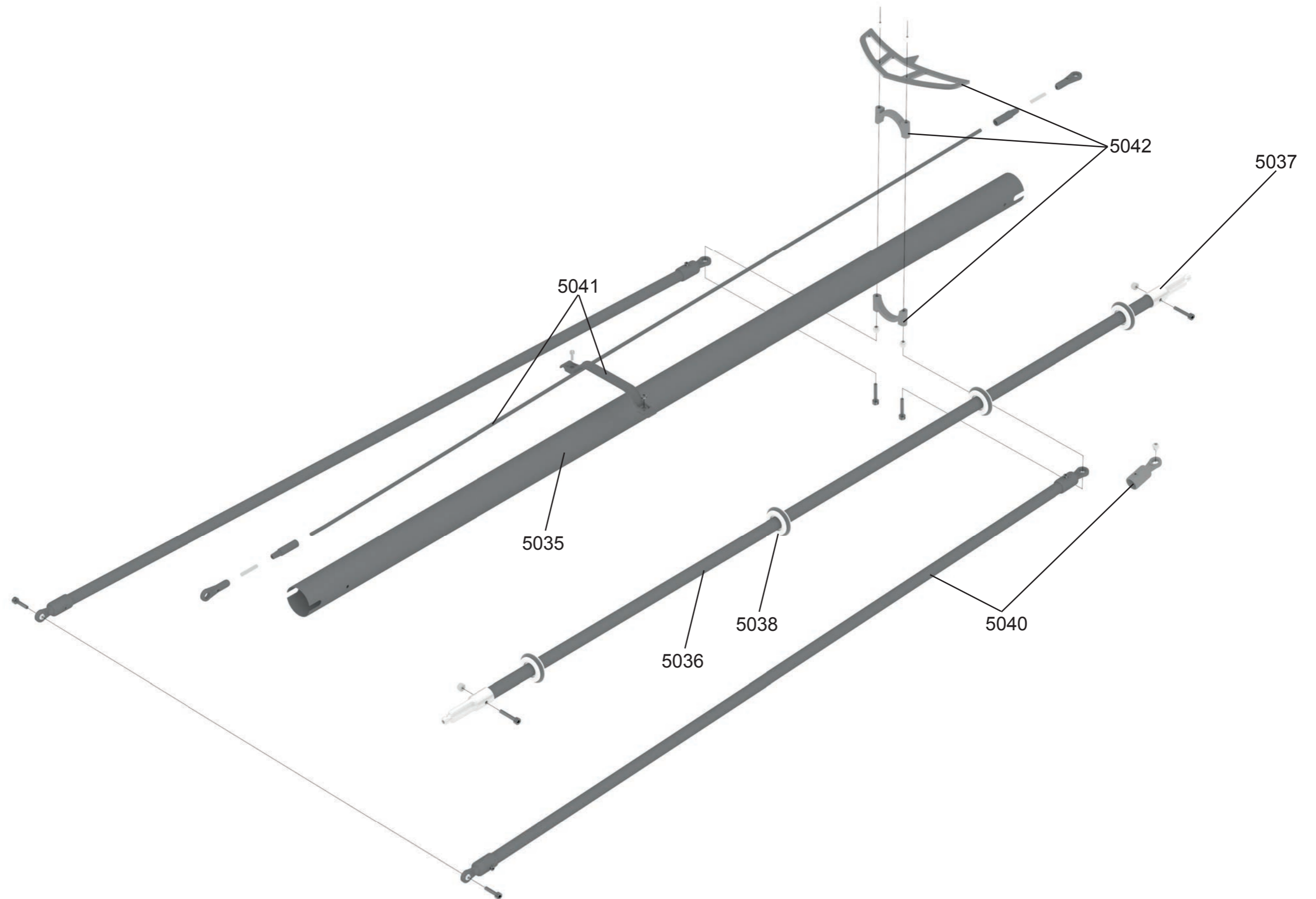

17 Overview Spare Parts Tail Rotor

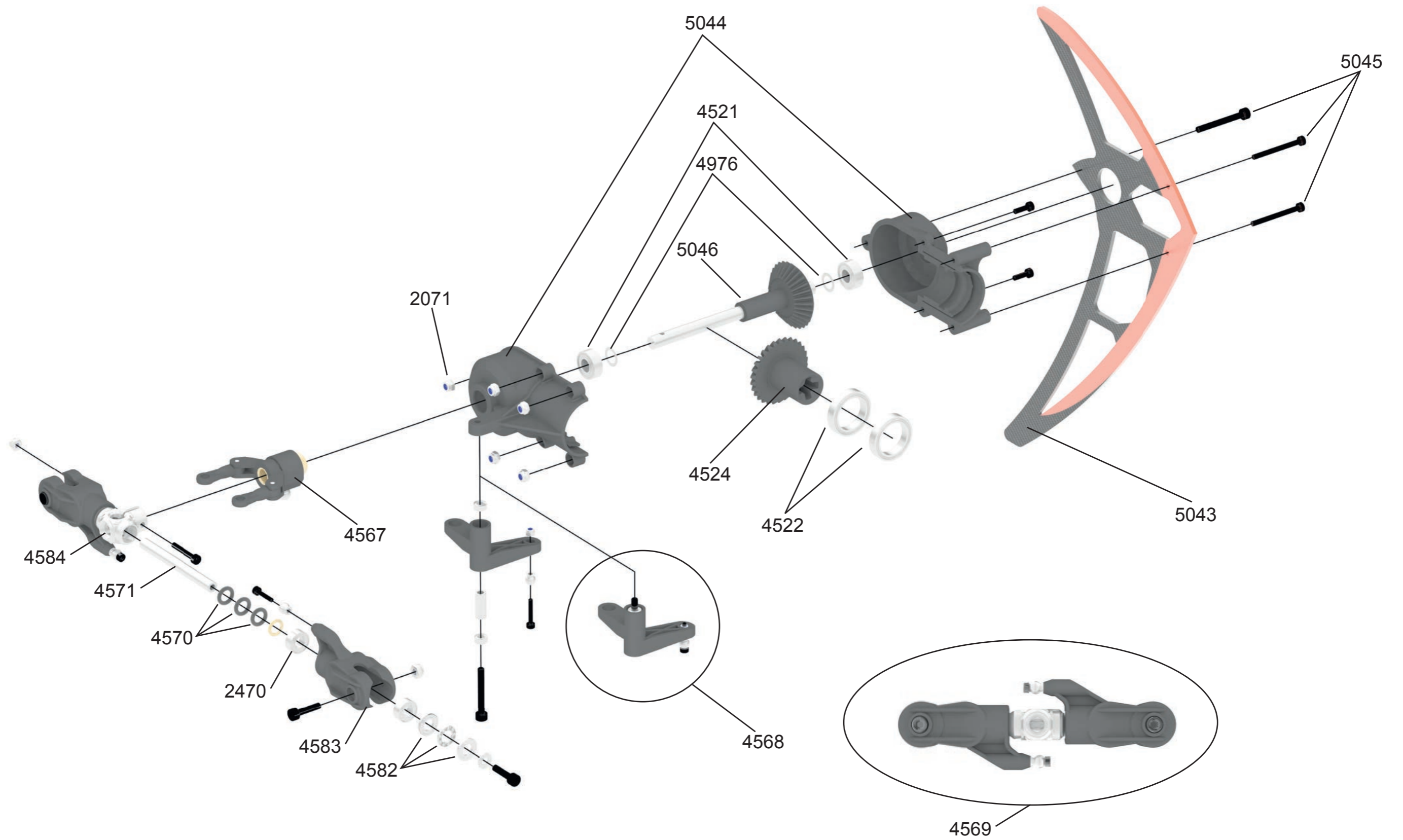

18 Overview Spare Parts Rotor Head

