



HELICOPTER

MANUAL

GOBLIN 570 SPORT 



 SAB HELI DIVISION 

## Goblin 570 Sport Manual

Release 1.0 - March 2018

### WORLD DISTRIBUTION

[www.goblin-helicopter.com](http://www.goblin-helicopter.com)

For sales inquiries, please email: [sales@goblin-helicopter.com](mailto:sales@goblin-helicopter.com)

For info inquiries, please email: [support@goblin-helicopter.com](mailto:support@goblin-helicopter.com)

Attention: If you are a consumer and have questions or need of assistance, please contact in a first time the Goblin retailer where you made the purchase

### EUROPEAN DISTRIBUTION

[www.sabitaly.it](http://www.sabitaly.it)

For sales and information, please email: [sales@sabitaly.it](mailto:sales@sabitaly.it)

Attention: If you are a consumer and have questions or need of assistance, please contact in a first time the Goblin retailer where you made the purchase

### USA DISTRIBUTION

[www.sabusa.it](http://www.sabusa.it)

For sales and information, please email: [sales@sabusa.it](mailto:sales@sabusa.it)

Attention: If you are a consumer and have questions or need of assistance, please contact in a first time the Goblin retailer where you made the purchase

Please read this user manual carefully, it contains instructions for the correct assembly of the model.  
Please refer to the web site [www.goblin-helicopter.com](http://www.goblin-helicopter.com) for updates and other important information.

**VERY IMPORTANT**

In the Manual bag you will find a product card your with serial number. Please take a moment to register your kit online via our web site at:

<http://www.goblin-helicopter.com/>

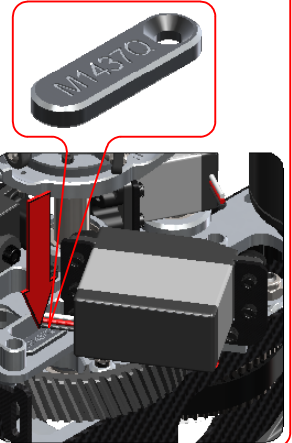


It is extremely important that you take a moment to register your helicopter with us. This is the only way to ensure that you are properly informed about changes to your kit, such as upgrades, retrofits and other important developments. SAB Heli Division cannot be held responsible for issues arising with your model and will not provide support unless you register your serial number.

To mount the serial number tag on your helicopter, please refer to page 25.

*Thank you for your purchase, we hope you enjoy your new Goblin helicopter!*

SAB Heli Division



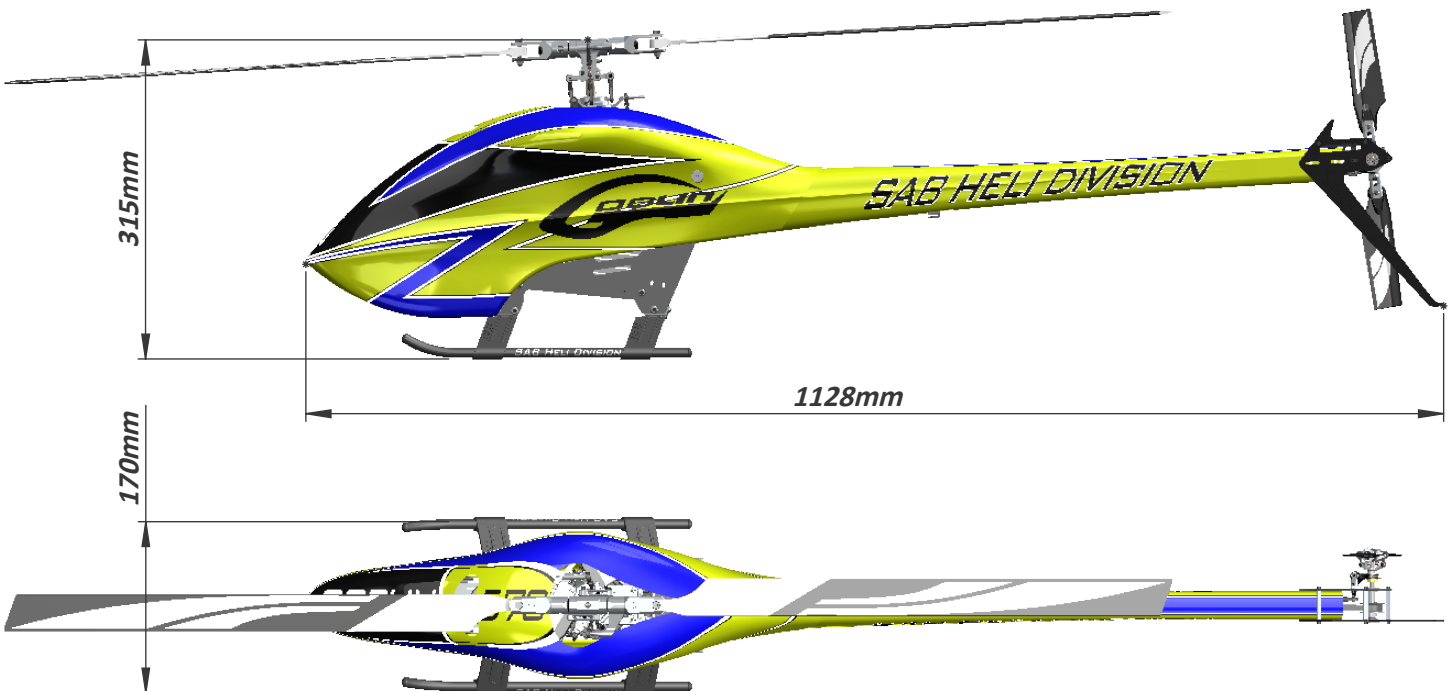
**INDEX**

- Chapter 01 – Specifications
- Chapter 02 – **Important Notes** ⚠
- Chapter 03 – In The Box
- Chapter 04 – Carbon Frame Assembly
- Chapter 05 – Transmission Assembly
- Chapter 06 – Main Rotor Assembly

- Chapter 07 – Installation Of The Servos
- Chapter 08 – Assembling The Modules
- Chapter 09 – Installation Of The Motor
- Chapter 10 – Installation Of The ESC
- Chapter 11 – Installation Of The FBL and Bec
- Chapter 12 – Tail Assembly

- Chapter 13 – Installation of The Boom
- Chapter 14 – Battery
- Chapter 15 – Canopy & Serial Number
- Chapter 16 – **In Flight / Maintenance** ⚠
- Chapter 17 – Spare Parts

**SPECIFICATIONS**



- Main rotor diameter: 1278mm (with 570mm Blades)
- Tail rotor diameter: 260mm (with 95mm Tail Blades)
- Air frame weight: 2370g ( Excluding Batteries )
- Motor size: Maximum 52mm diameter, maximum height 56mm.
- Battery compartment:
  - \* 6S–5000/5500 mAh : Max dimension 50x60x200mm.
  - \* 12S–2600/3300 mAh : Max dimension 50x45x280mm.

**IMPORTANT NOTES**

- \*This radio controlled helicopter is not a toy.
  - \*This radio controlled helicopter can be very dangerous.
  - \*This radio controlled helicopter is a technically complex device which has to be built and handled very carefully.
  - \*This radio controlled helicopter must be built following these instructions. This manual provides the necessary information to correctly assemble the model. It is necessary to carefully follow all the instructions.
  - \*Inexperienced pilots must be monitored by expert pilots.
  - \*All operators must wear safety glasses and take appropriate safety precautions.
  - \*A radio controlled helicopter must only be used in open spaces without obstacles, and far enough from people to minimize the possibility of accidents or of injury to property or persons.
  - \*A radio controlled helicopter can behave in an unexpected manner, causing loss of control of the model, making it very dangerous.
  - \*Lack of care with assembly or maintenance can result in an unreliable and dangerous model.
- \*Neither SAB Heli Division nor its agents have any control over the assembly, maintenance and use of this product. Therefore, no responsibility can be traced back to the manufacturer. You hereby agree to release SAB Heli Division from any responsibility or liability arising from the use of this product.**

**SAFETY GUIDELINES**

- \*Fly only in areas dedicated to the use of model helicopters.
- \*Follow all control procedures for the radio frequency system.
- \*It is necessary that you know your radio system well. Check all functions of the transmitter before every flight.
- \*The blades of the model rotate at a very high speed; be aware of the danger they pose and the damage they may cause.
- \*Never fly in the vicinity of other people.

**DAMAGE LIMITS**

SAB HELI DIVISION SHALL NOT BE LIABLE FOR SPECIAL, INDIRECT OR CONSEQUENTIAL DAMAGES, LOSS OF PROFITS OR PRODUCTION OR COMMERCIAL LOSS IN ANY WAY CONNECTED WITH THE PRODUCT, WHETHER SUCH CLAIM IS BASED IN CONTRACT, WARRANTY, NEGLIGENCE, OR STRICT LIABILITY. Further, in no event shall the liability of SAB Heli Division exceed the individual price of the Product on which liability is asserted. As SAB Heli Division has no control over use, setup, final assembly, modification or misuse, no liability shall be assumed nor accepted for any resulting damage or injury. By the act of use, setup or assembly the user accepts all resulting liability. If you as the Purchaser or user are not prepared to accept the liability associated with the use of this Product, you are advised to return this Product immediately in new and unused condition to the place of purchase.

**LIMITED WARRANTY.**

SAB Heli Division reserves the right to change or modify this warranty without notice and disclaims all other warranties, express or implied.

**(a)** This warranty is limited to the original Purchaser (“Purchaser”) and is not transferable. REPLACEMENT AS PROVIDED UNDER THIS WARRANTY IS THE EXCLUSIVE REMEDY OF THE PURCHASER This warranty covers only those Products purchased from an authorized SAB Heli Division dealer. Third party transactions are not covered by this warranty. Proof of purchase is required for warranty claims.







**(b)** Limitations- SAB HELI DIVISION MAKES NO WARRANTY OR REPRESENTATION, EXPRESS OR IMPLIED, ABOUT NONINFRINGEMENT, MERCHANTABILITY OR FITNESS FOR A PARTICULAR PURPOSE OF THE PRODUCT. THE PURCHASER ACKNOWLEDGES THAT THEY ALONE HAVE DETERMINED THAT THE PRODUCT WILL SUITABLY MEET THE REQUIREMENTS OF THE PURCHASER’S INTENDED USE.

**(c)** Purchaser Remedy- SAB Heli Division’s sole obligation hereunder shall be that SAB Heli Division will, at its option, replace any Product determined by SAB Heli Division to be defective In the event of a defect, this is the Purchaser’s exclusive remedy. Replacement decisions are at the sole discretion of SAB Heli Division. This warranty does not cover cosmetic damage or damage due to acts of God, accident, misuse, abuse, negligence, commercial use, or modification of or to any part of the Product. This warranty does not cover damage due to improper installation, operation, maintenance or attempted repair by anyone

**NOTES FOR ASSEMBLY**

Please refer to this manual for assembly instructions for this model. Follow the order of assembly indicated. The instructions are divided into chapters, which are structured in a way that each step is based on the work done in the previous step. Changing the order of assembly may result in additional or unnecessary steps.

Use thread lockers and retaining compounds as indicated. In general, each bolt or screw that engages with a metal part requires thread lock. It is necessary to pay attention to the symbols listed below:

 <p><b>Important</b></p>	 <b>Bag xx</b> <p>Indicates that for this assembly phase you need materials that are in bag xx.</p>	 <p>Use retaining compound ( SAB HA115-S )</p>
 <p>Use Thread Locker Medium Strength ( SAB HA116-S )</p>	 <p>Use CA Glue</p>	 <p>Use Proper Lubricant</p>

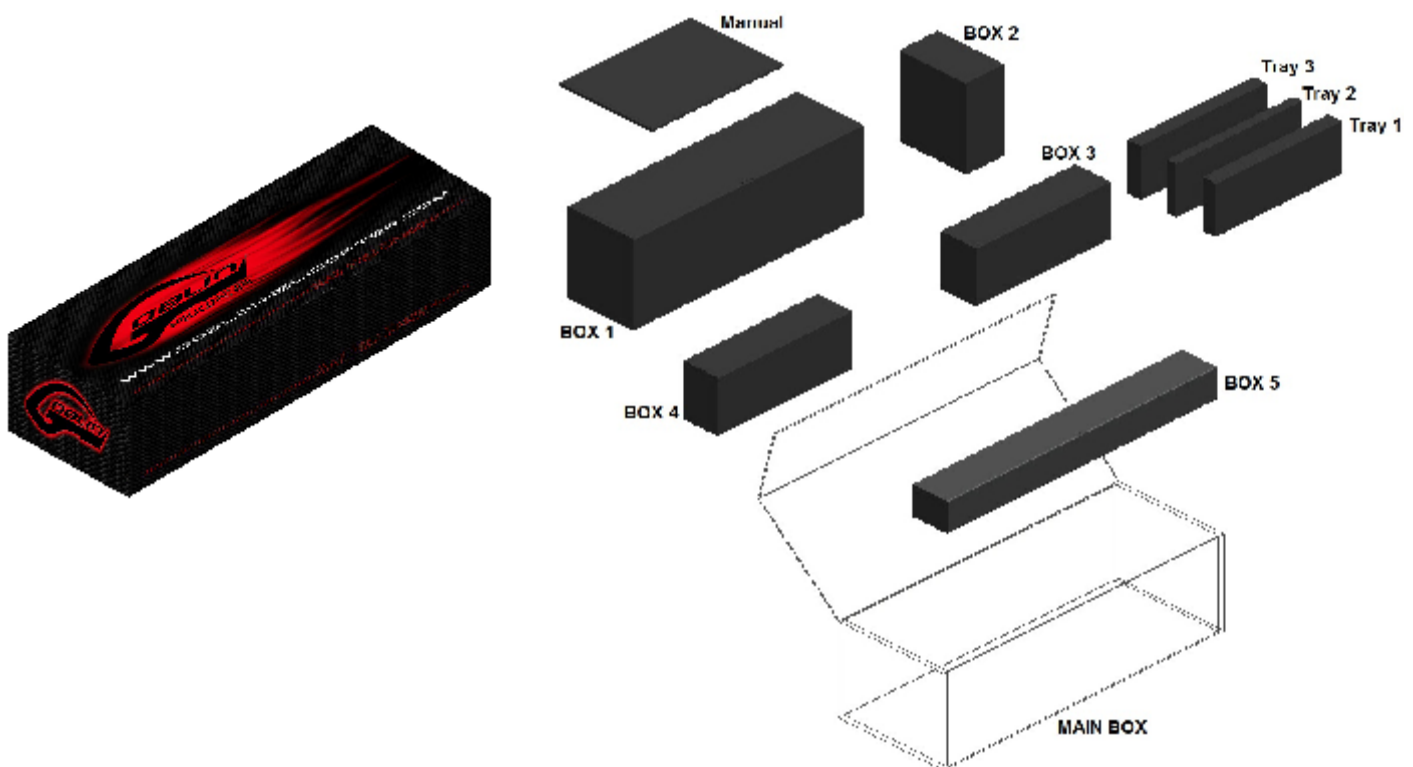
**ADDITIONAL COMPONENTS REQUIRED**

- \*Electric Motor: 6S–1000/1400 Kv, 12S–500/700 Kv maximum diameter 52mm, maximum height 56mm, pinion shaft diameter 5 - 6mm ( 6mm is suggested )
- \*Speed controller: 6S minimum 100A, 12S minimum 80A
- \*Batteries: 6S–5000/5500 mAh, 12S–2600/3300 mAh
- \*1 flybarless 3 axis control unit
- \*Radio power system, if not integrated with the ESC
- \*3 cyclic servos
- \*1 tail rotor servo
- \*6 channel radio control system on 2.4 GHz

**TOOLS, LUBRICANTS, ADHESIVES**

- \*Generic pliers
- \*Hexagonal driver, size 1.5, 2, 2.5, 3, 4 mm
- \*4mm T-Wrench
- \*5.5mm Socket wrench (for M3 nuts)
- \*7mm Hex fork wrench (for M4 nuts)
- \*Medium threadlocker (eg. SAB HA116-S)
- \*Strong retaining compound (eg. SAB HA115-S)
- \*Spray lubricant (eg. Try-Flow Oil)
- \*Synthetic grease (eg. Tri-Flow Synthetic Grease)
- \*Grease (eg. Vaseline Grease)
- \*Cyanoacrylate adhesive
- \*Pitch Gauge (for set-up)
- \*Soldering equipment (for motor wiring)

**Inside the box:**



**Inside The Box:**

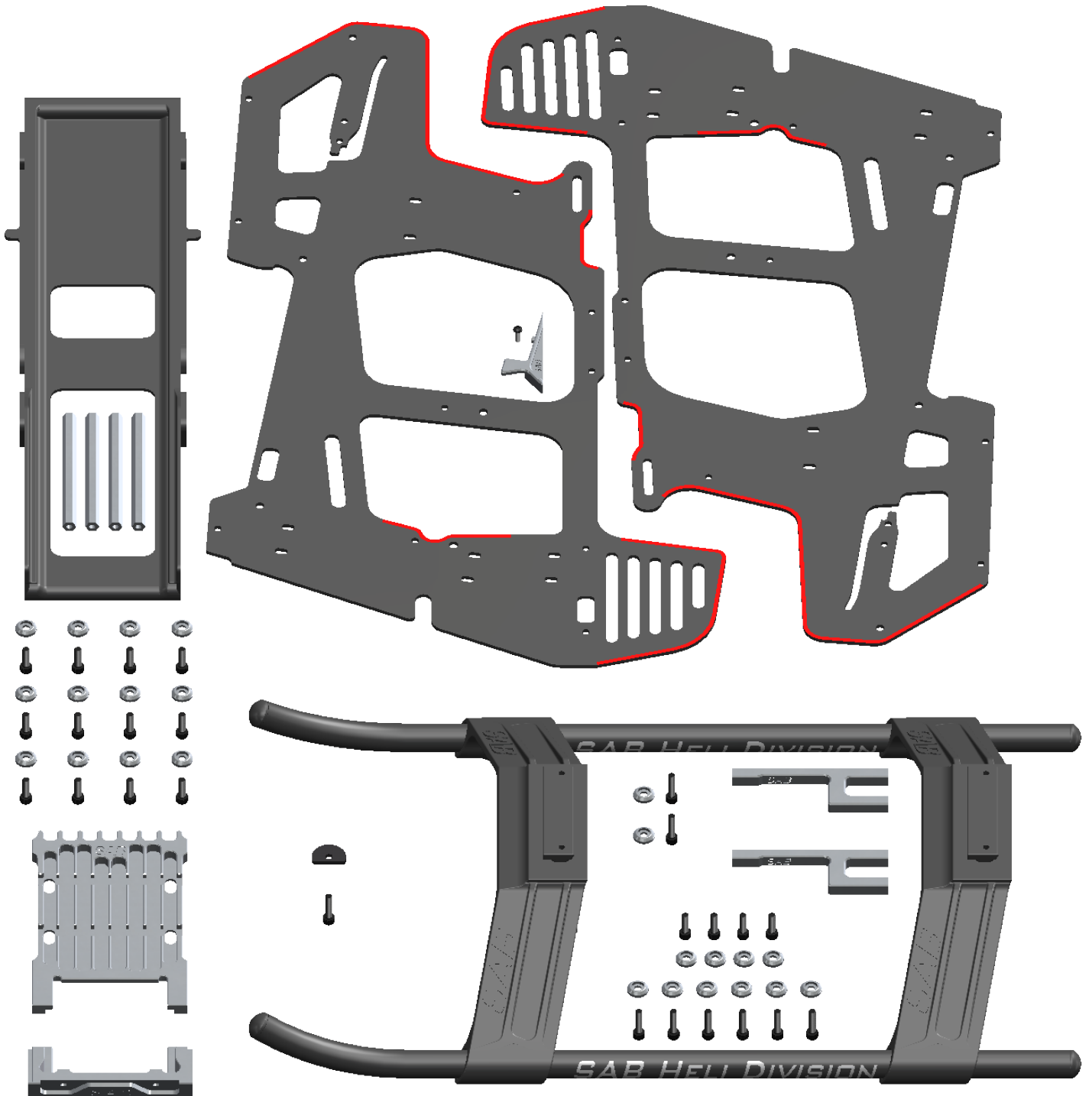
- Box 1: Canopy, Bags A, B, C, D, E .
- Box2: Optional Combo Components
- Box 3: Mechanical Parts in 3 trays:
  - Tray 1: Head parts
  - Tray 2: Main structure
  - Tray 3: Transmission parts
- Box 4: Bags
- Box 5: Blades, Tail Blades, Boom, Carbon Rod

The assembly process is described in the following chapters. Each chapter provides you with the box, bag and/or foam tray numbers you will need for that chapter. The information is printed in a red box in the upper right hand corner of the page at the beginning of every chapter.

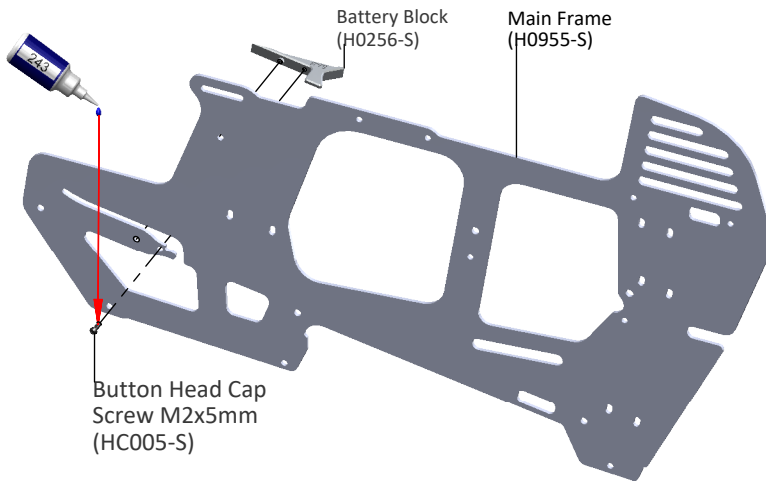
# 4-Carbon Frame



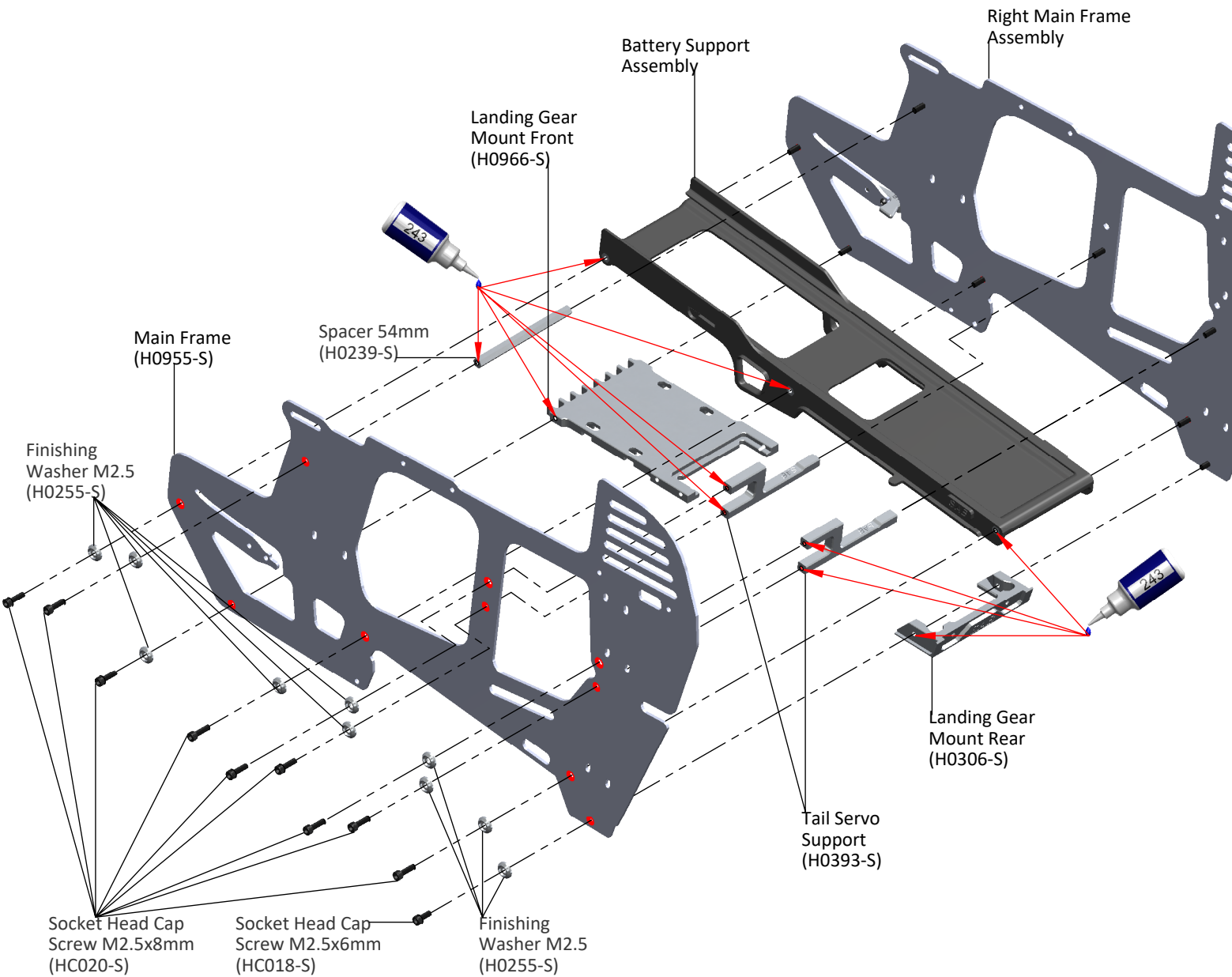
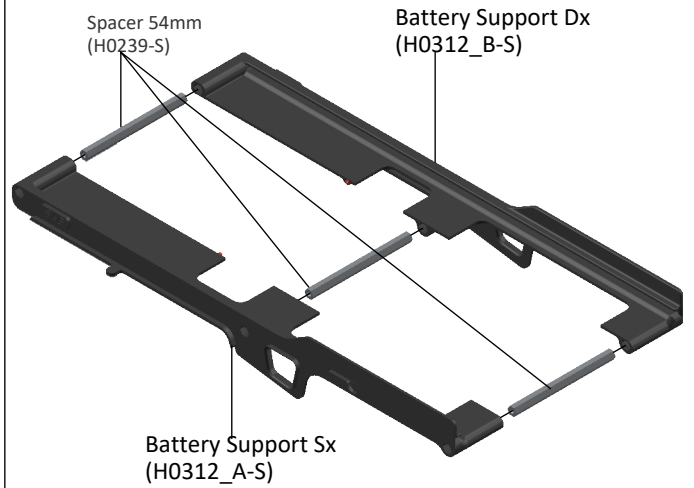
The manufacturing process of the carbon parts often leaves micro-burrs and sharp edges. We recommend de-burring the edges to minimize the risks of electrical wire cuts, etc. Very Important in red line zone.



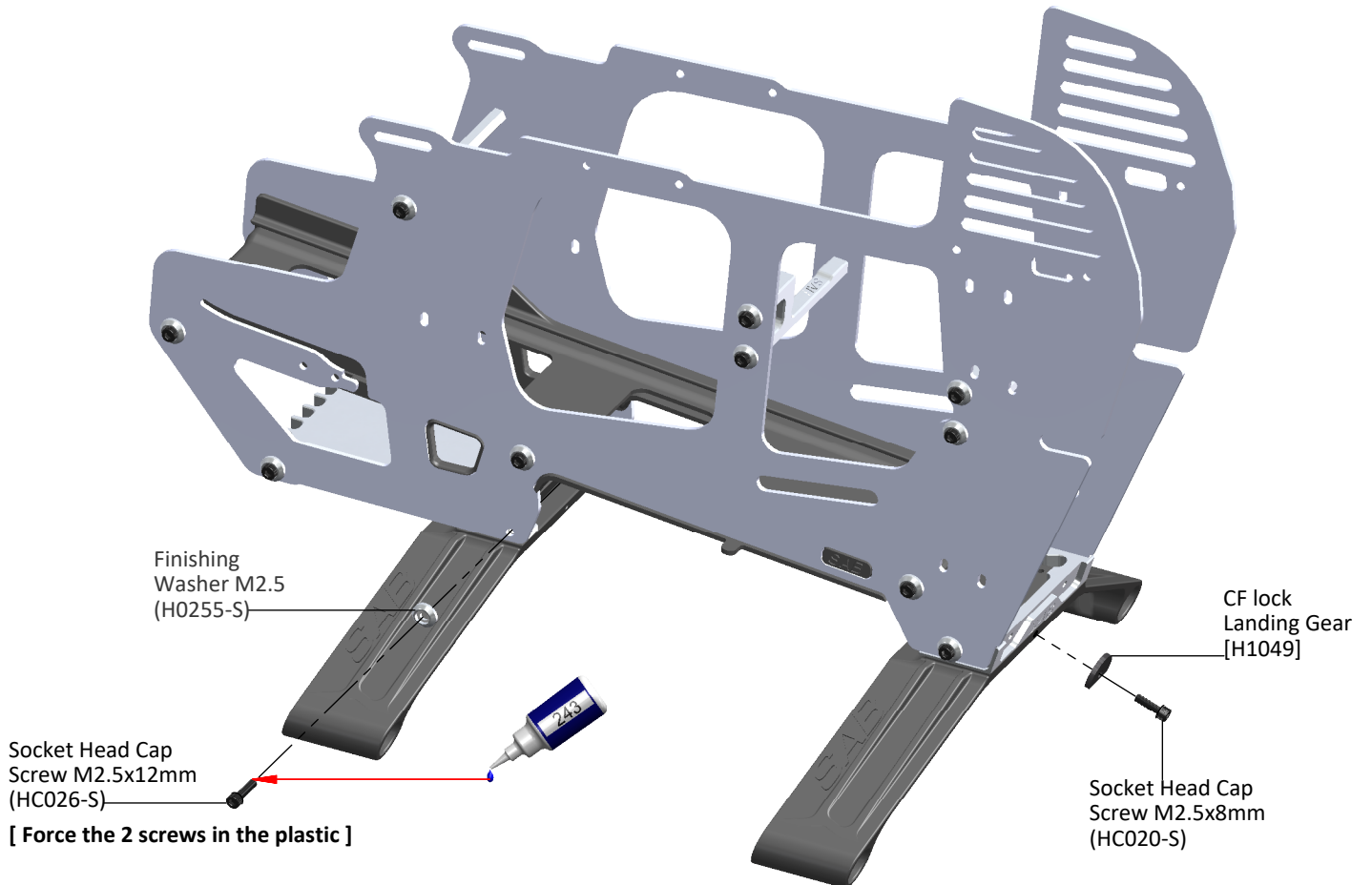
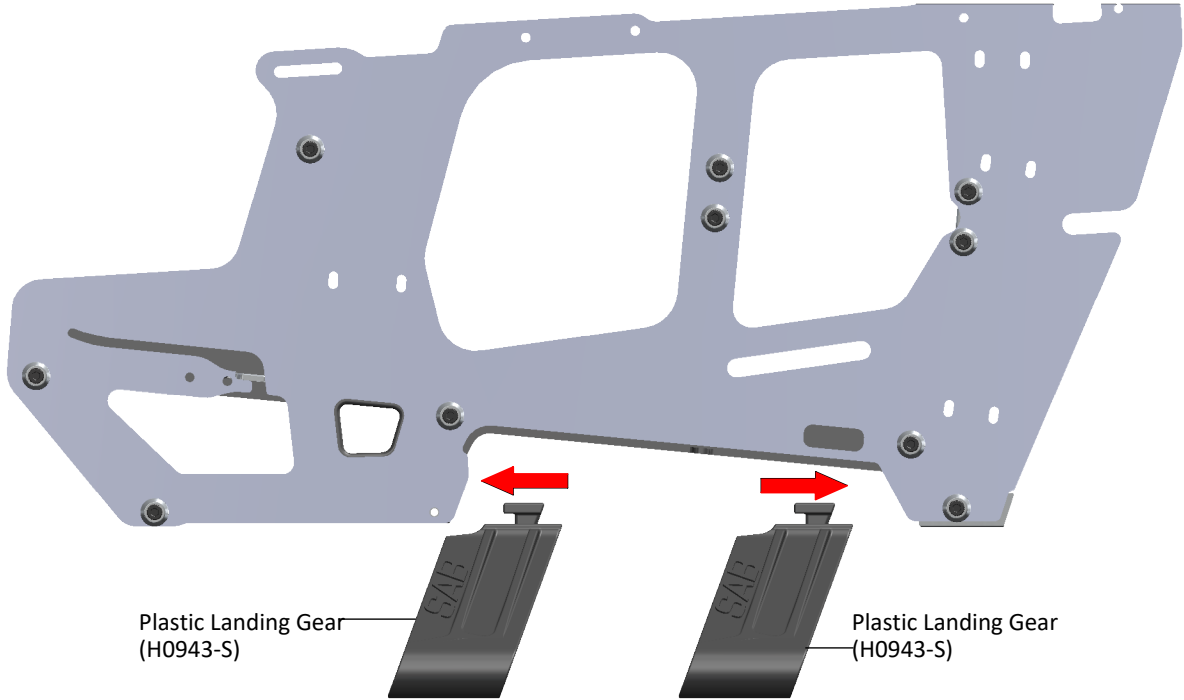
**Right Main Frame Assembly**



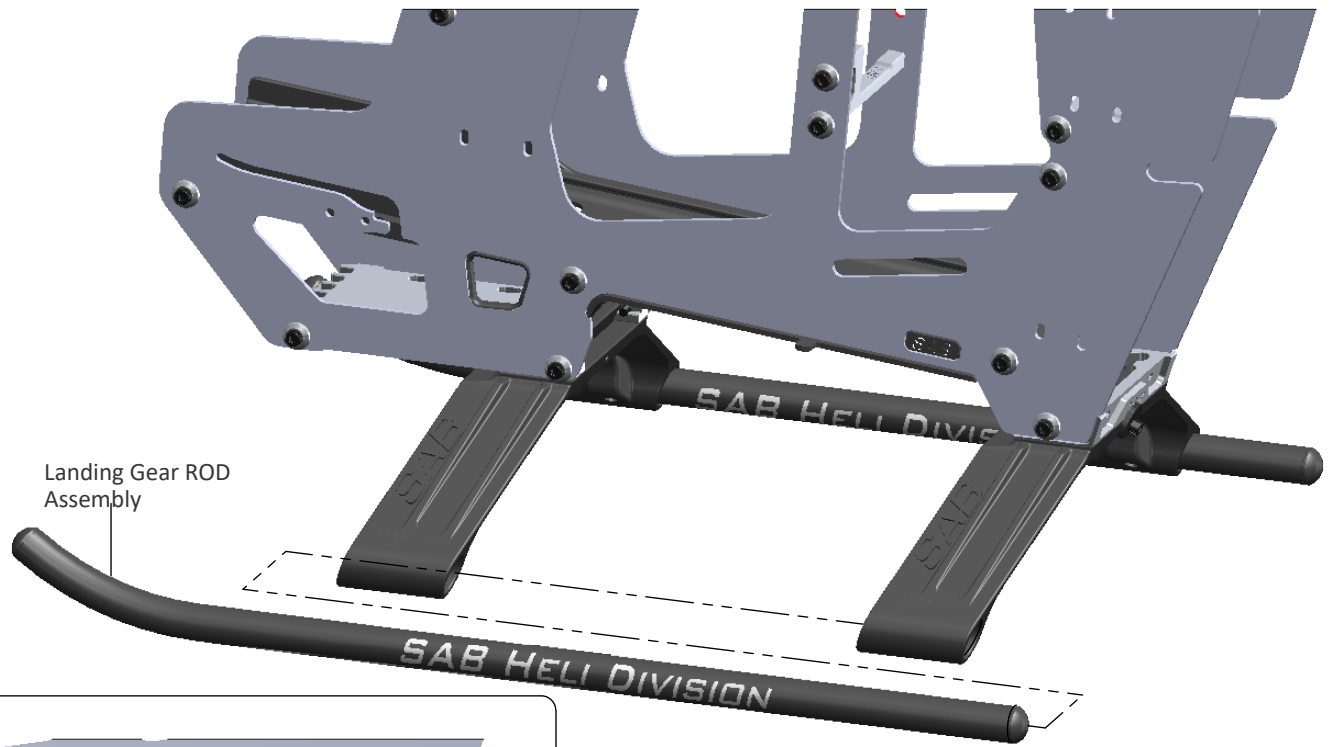
**Battery Support Assembly**



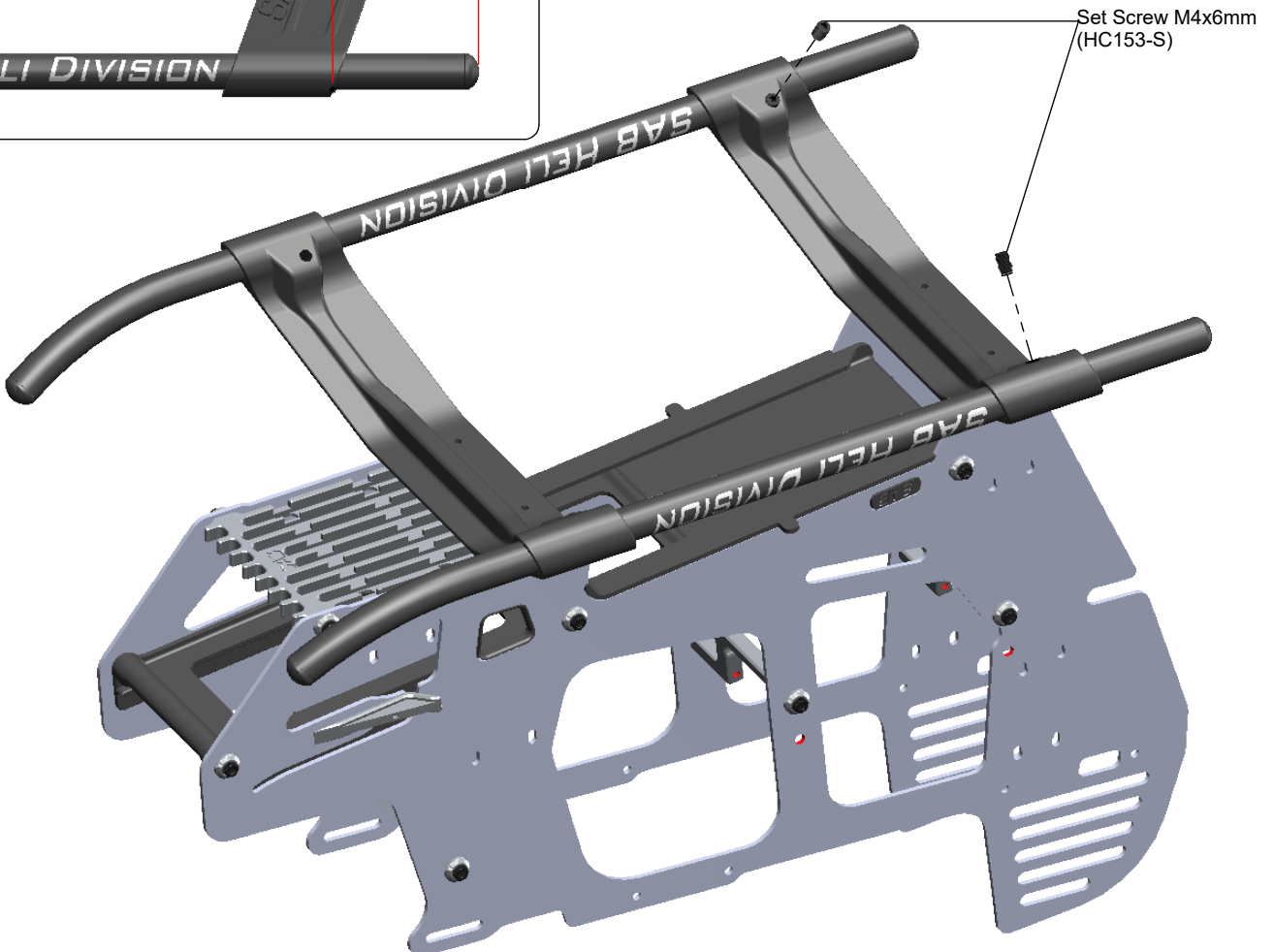
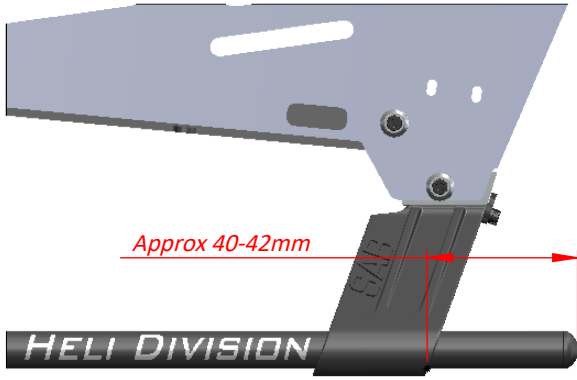
Landing Gear ROD Assembly ...x2

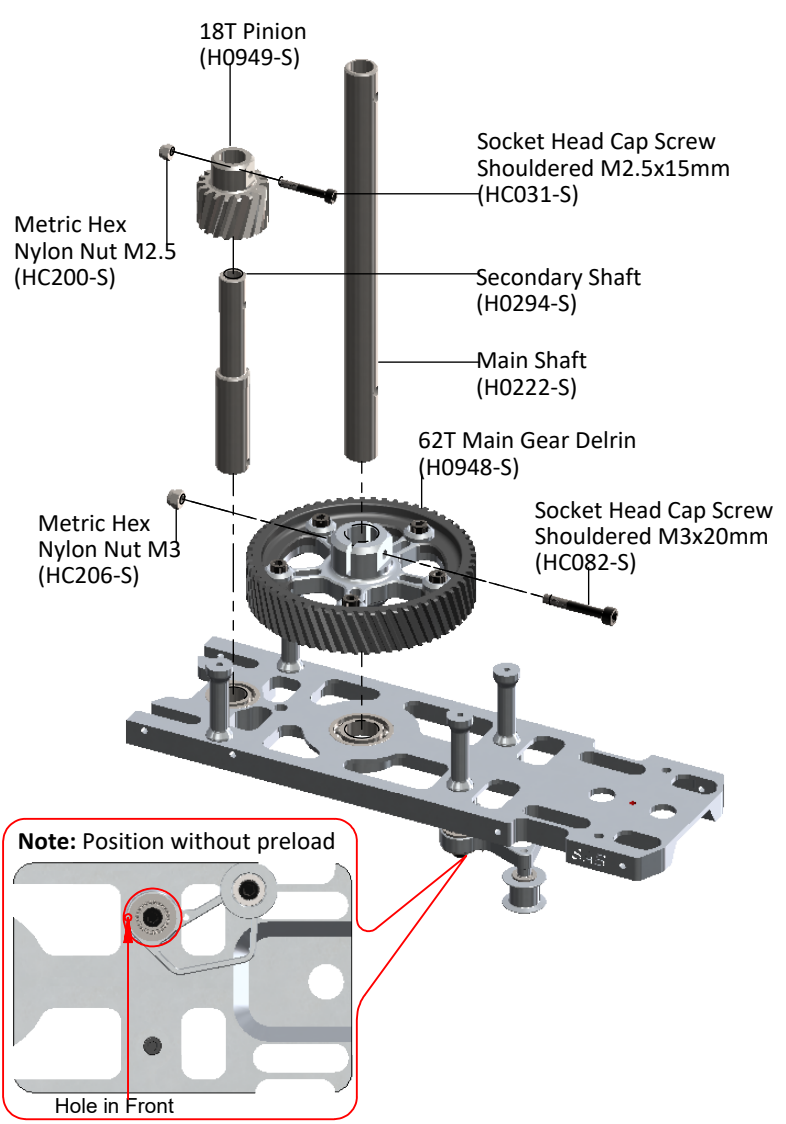
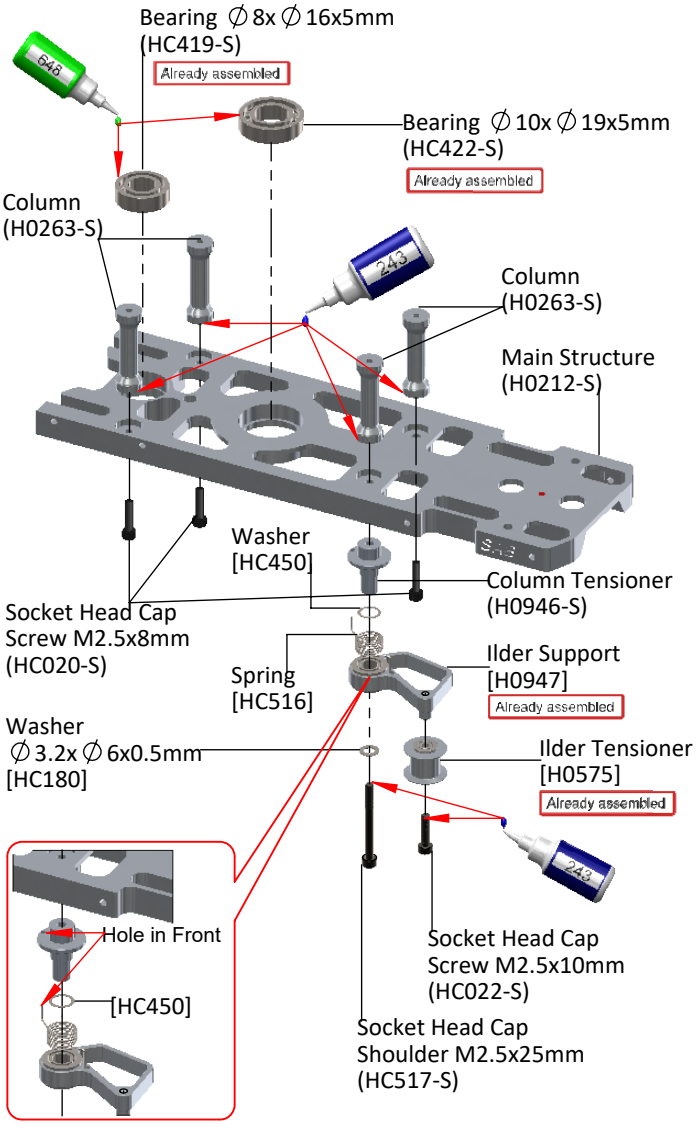




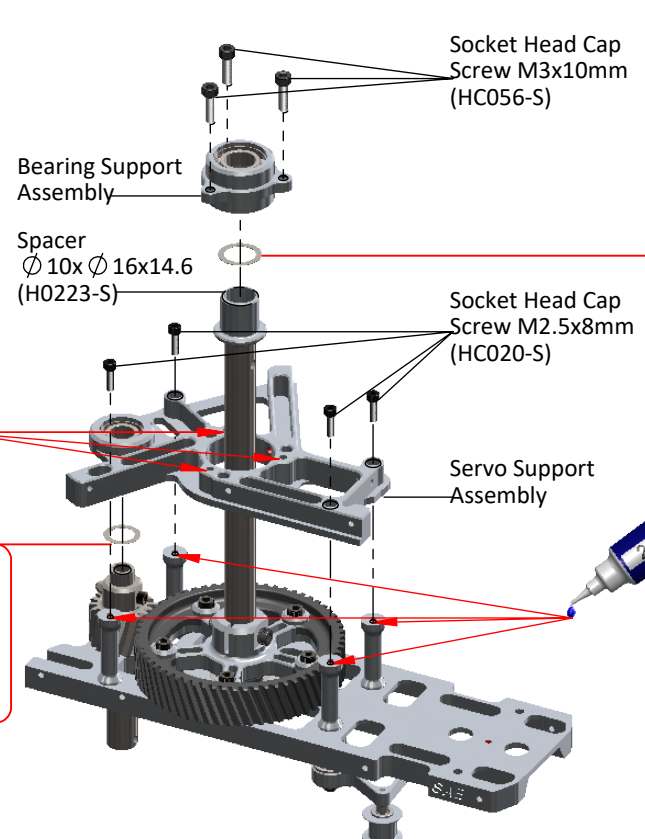
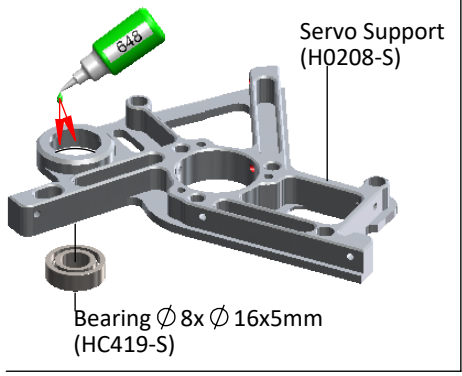


NOTE





Servo Support Assembly



Washer  $\phi 10 \times \phi 16 \times 0.1 \text{mm}$  (HC234-S)  
Tighten the three screw M3. After tightening, check the axial play of the main shaft. It is possible to reduce any axial play by adding shims.

**IMPORTANT:** Very carefully check to make sure you can turn the main shaft freely. If you feel too much friction, you have used too many shims, you can remove a shim until the shaft turns freely.

Washer  $\phi 8 \times \phi 14 \times 0.2 \text{mm}$  (HC228-S)  
**(Use additional shims to remove any axial play)**  
[Already assembled]

60T Pulley Assembly

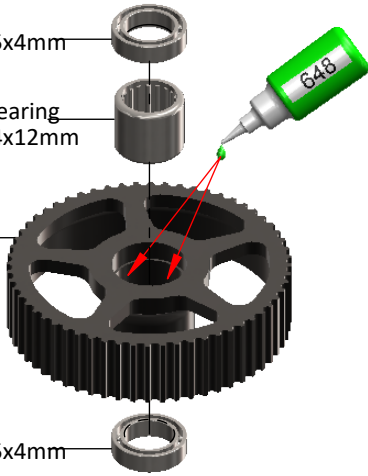
Already assembled

Bearing  
 $\varnothing 10 \times \varnothing 15 \times 4 \text{mm}$   
 (HC420-S)

One Way Bearing  
 $\varnothing 10 \times \varnothing 14 \times 12 \text{mm}$   
 (HC442-S)

60T Pulley  
 (H0295-S)

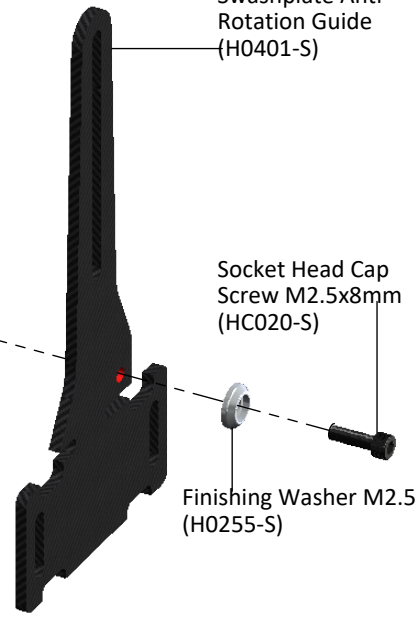
Bearing  
 $\varnothing 10 \times \varnothing 15 \times 4 \text{mm}$   
 (HC420-S)



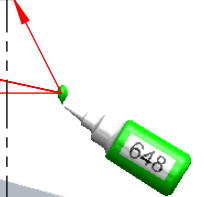
Swashplate Anti-Rotation Guide  
 (H0401-S)

Socket Head Cap Screw M2.5x8mm  
 (HC020-S)

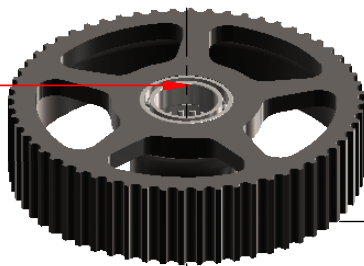
Finishing Washer M2.5  
 (H0255-S)



Sensor Support  
 (H0224-S)



eg: HUDY One Way Pulley Oil



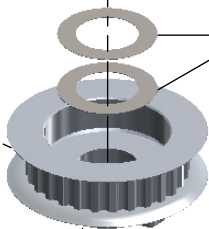
60T Pulley Assembly

Washer  $\varnothing 10 \times \varnothing 16 \times 0.1 \text{mm}$   
 (HC234-S)  
 (Use additional shims to remove any axial play)

Socket Head Cap Screw Shoudered M2.5x19mm  
 (HC033-S)



28T Front Tail Pulley Assembly  
 (H0304-S)

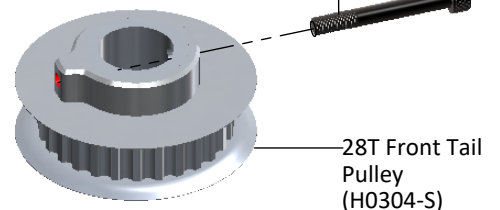


Socket Head Cap Screw M2.5x6mm  
 (HC018-S)

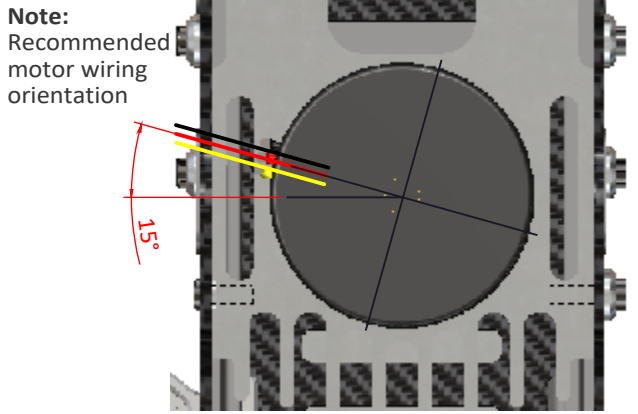
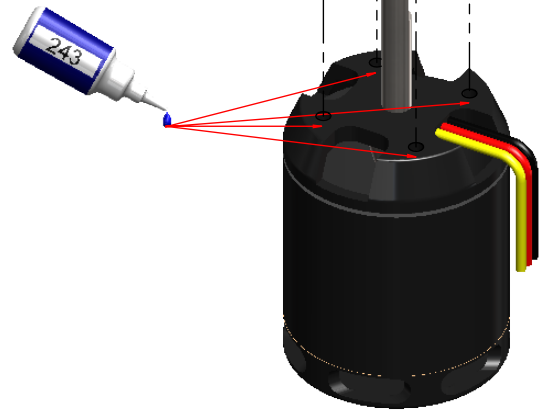
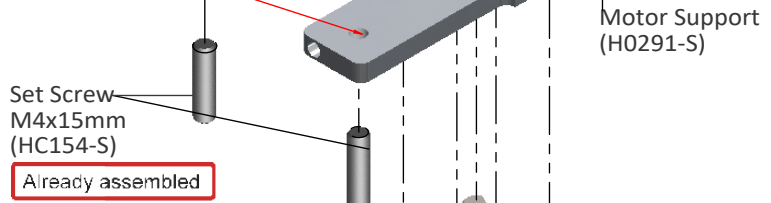
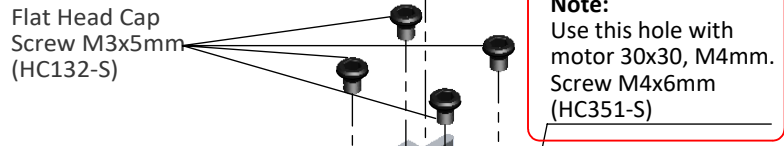
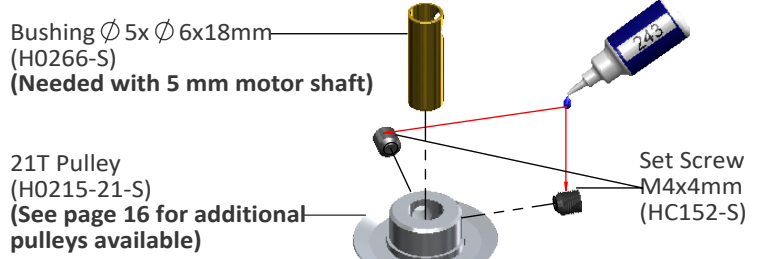
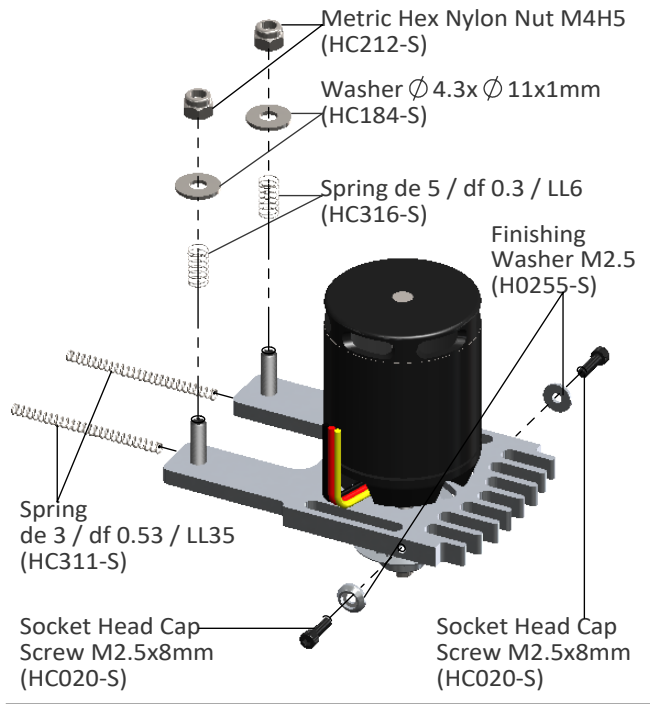
Front Tail Pulley

Already assembled

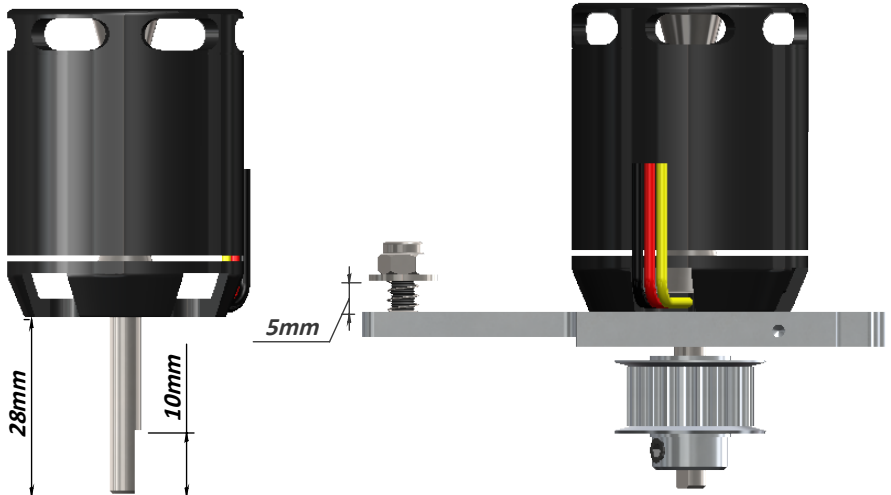
Socket Head Cap Screw Shoudered M2.5x19mm  
 (HC033-S)



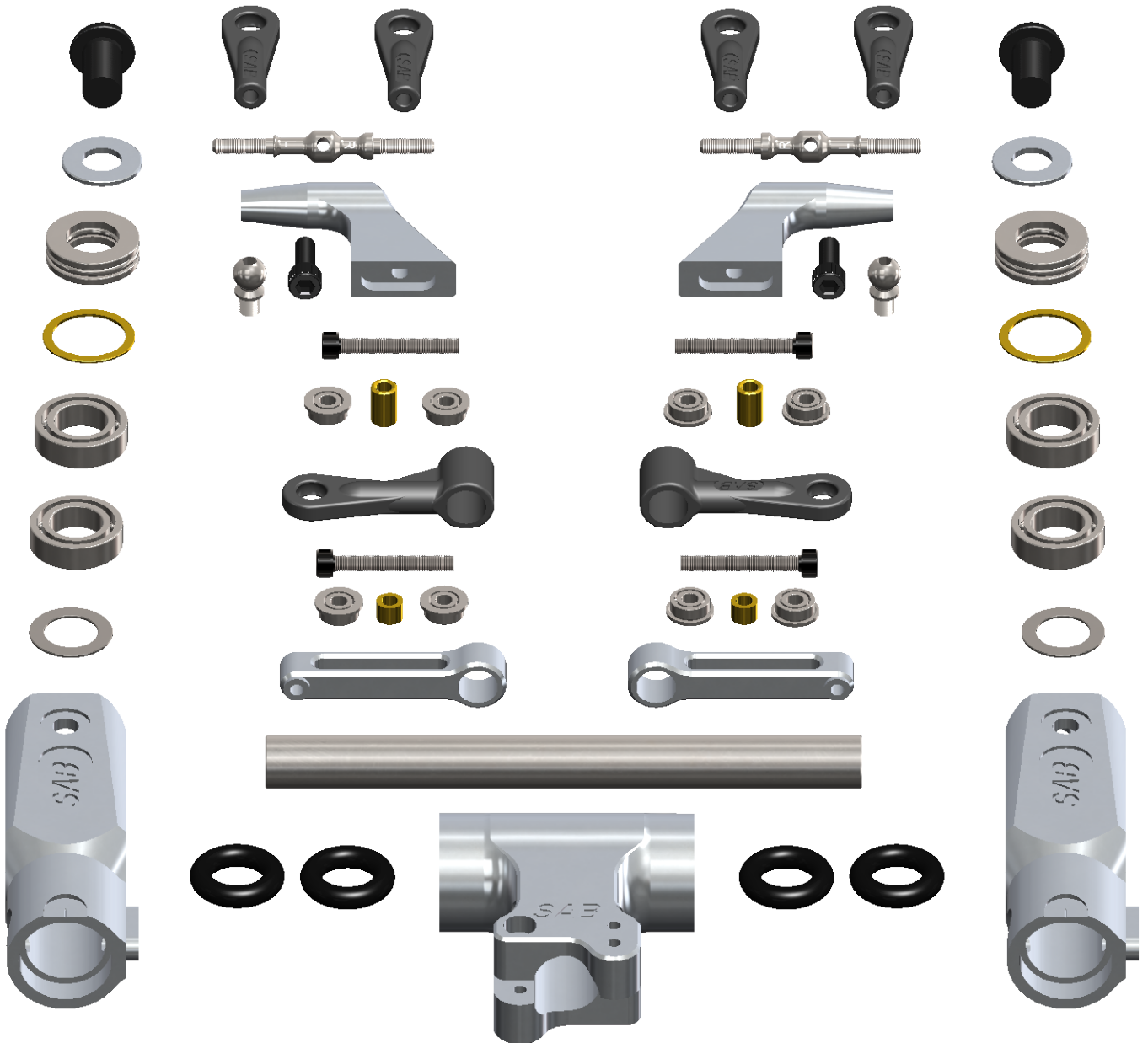
28T Front Tail Pulley  
 (H0304-S)



**Note:**  
 To maximize space for the batteries, it is advisable to shorten the motor shaft. Follow the dimensions given in this drawing. For the cut, you can use an electric tool like a "Dremel" with a cut-off disc. Additionally, ensure the motor shaft has an appropriate 'flat' for one of the set screws.

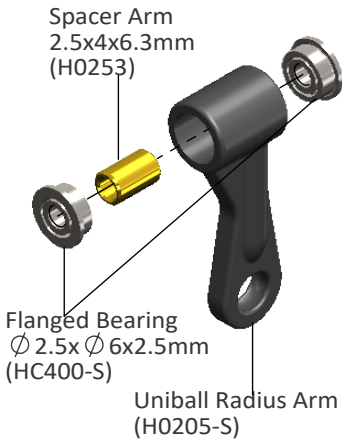


**6-Main Rotor**

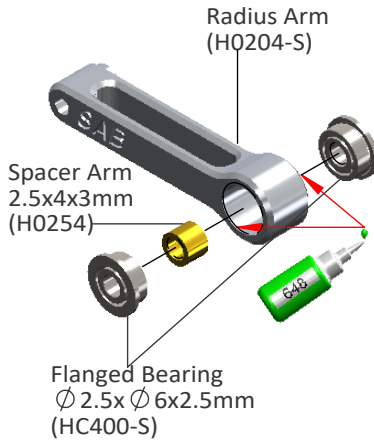




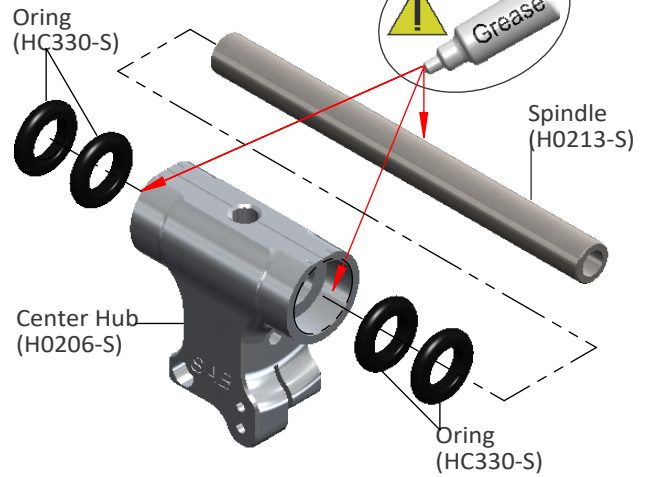
**Uniball Radius Arm ... x 2 Assembly**



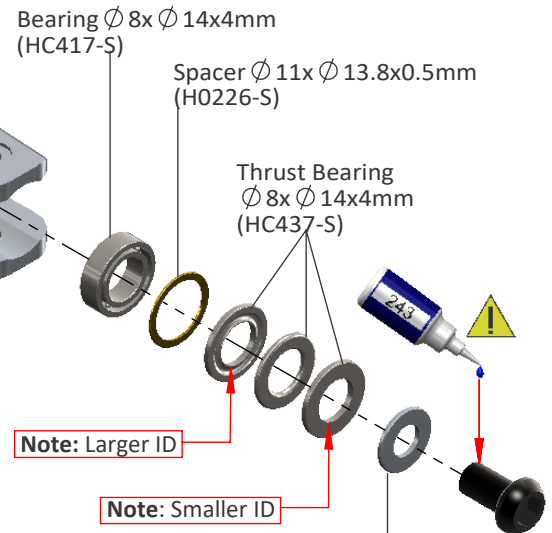
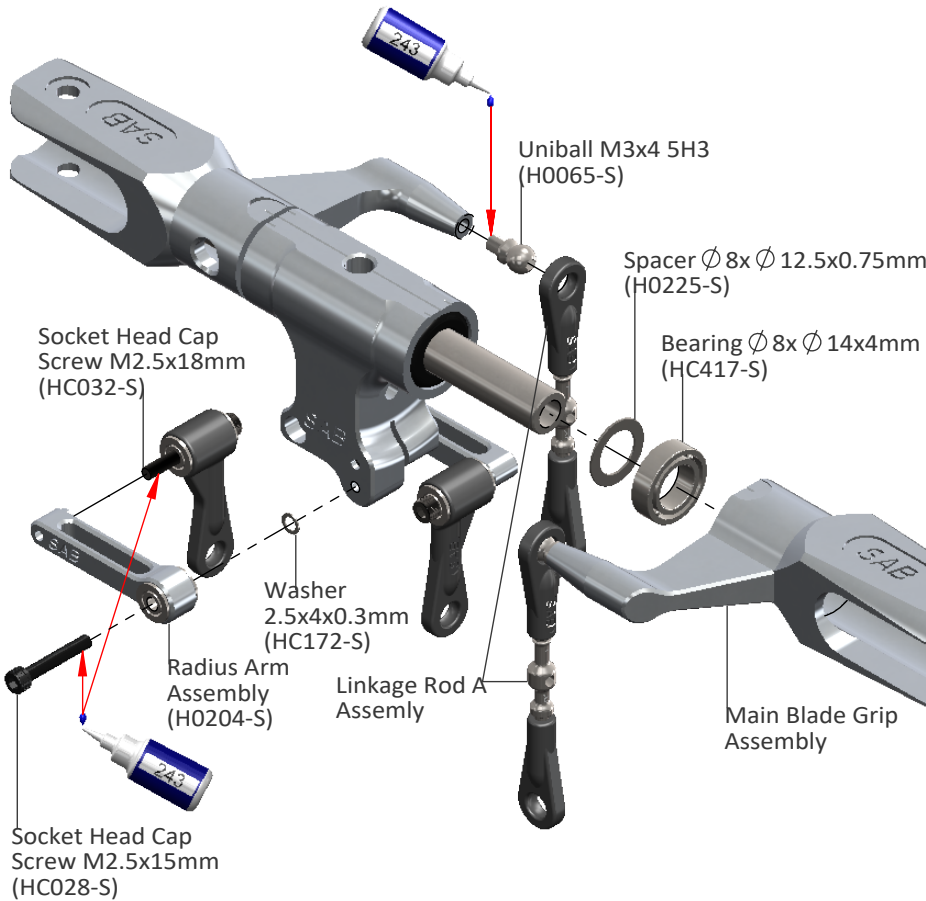
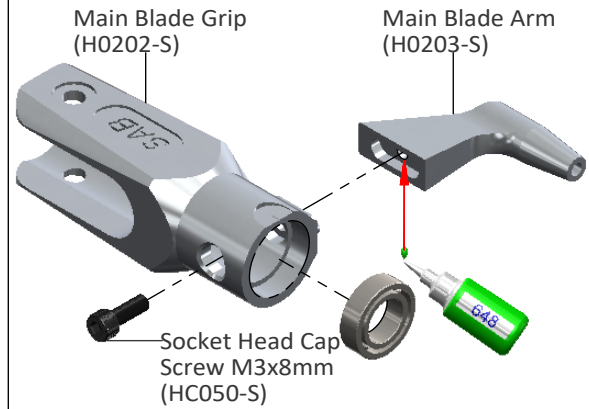
**Radius Arm ... x 2 Assembly**



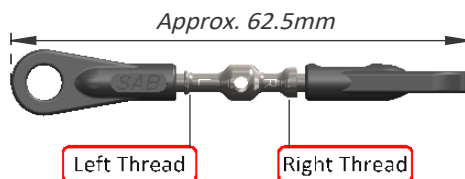
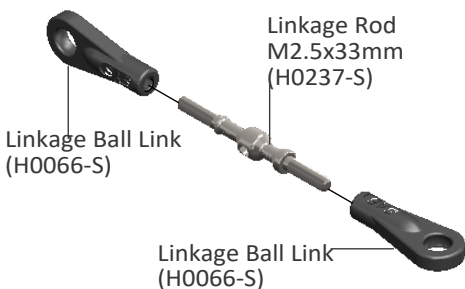
**Center Hub Assembly**



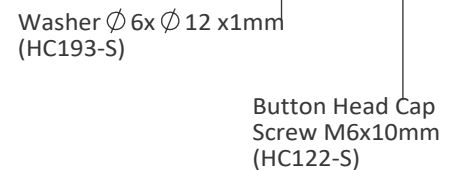
**Main Blade Grip Assembly ....x2**



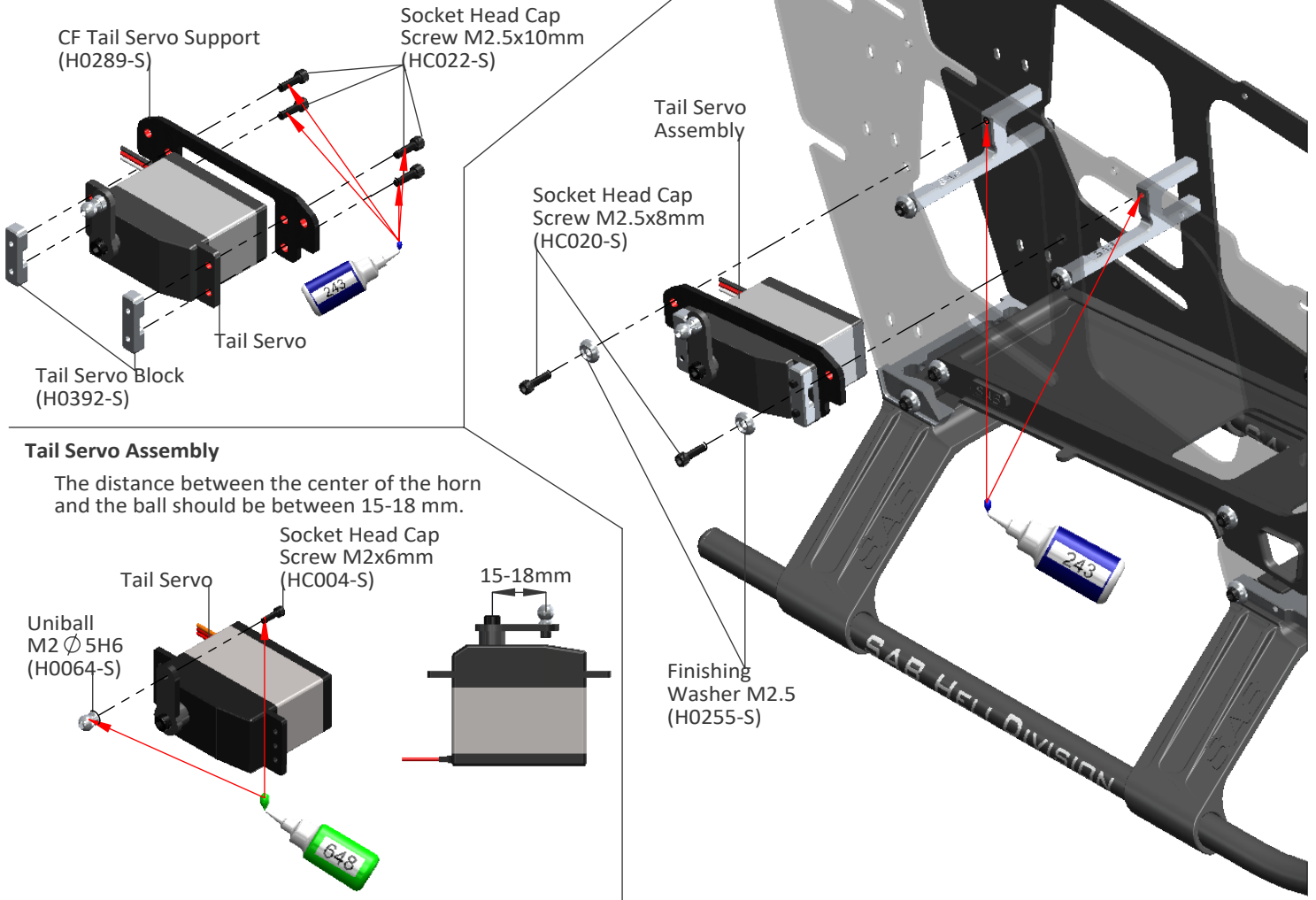
**Linkage Rod A Assembly . . . .x2**



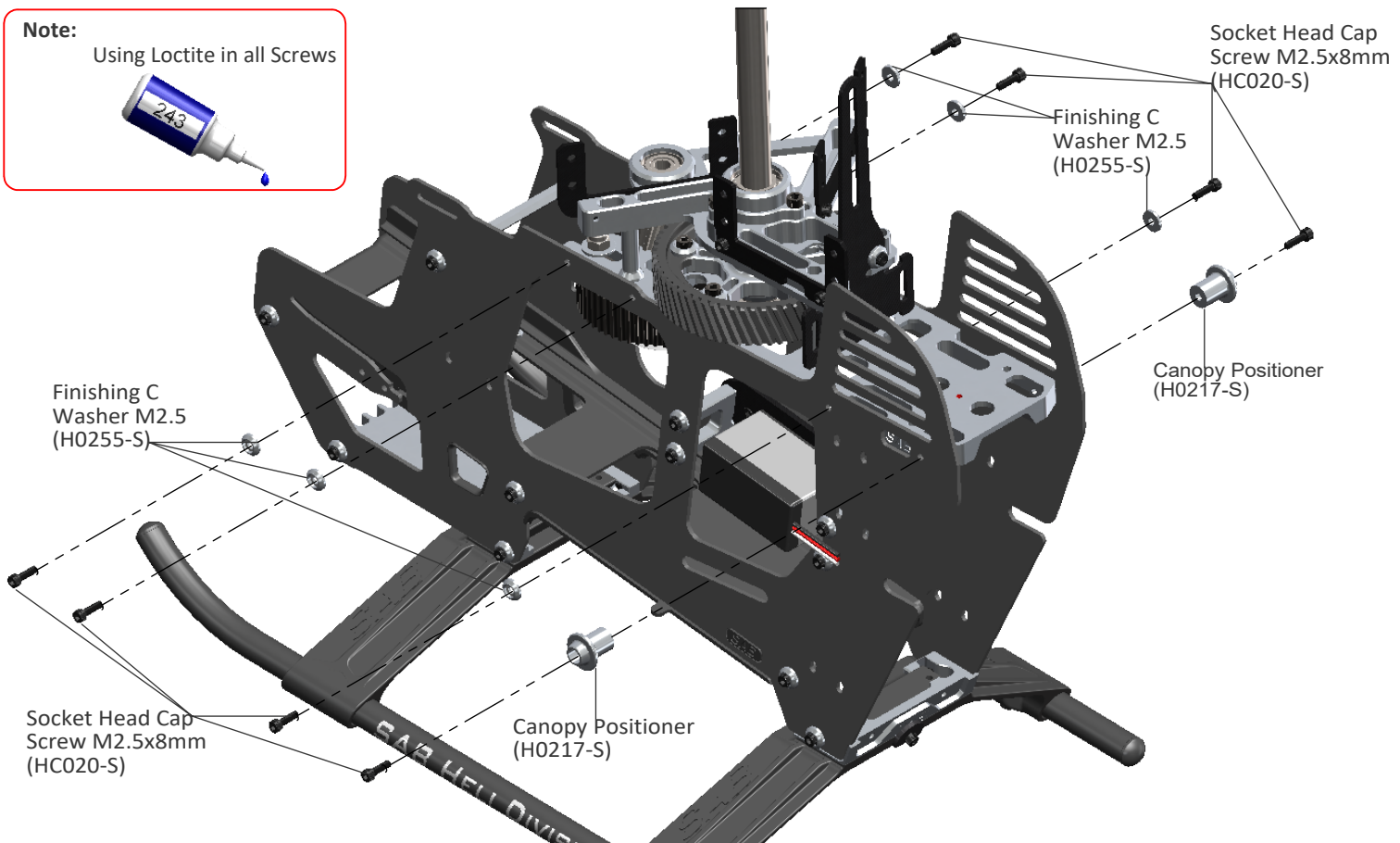
(Initial length for the rods from the swashplate to the blade grip.)



**Tail Servo Assembly**

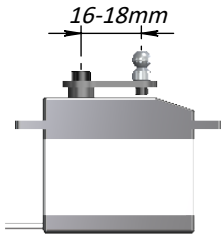


**Note:** Using Loctite in all Screws



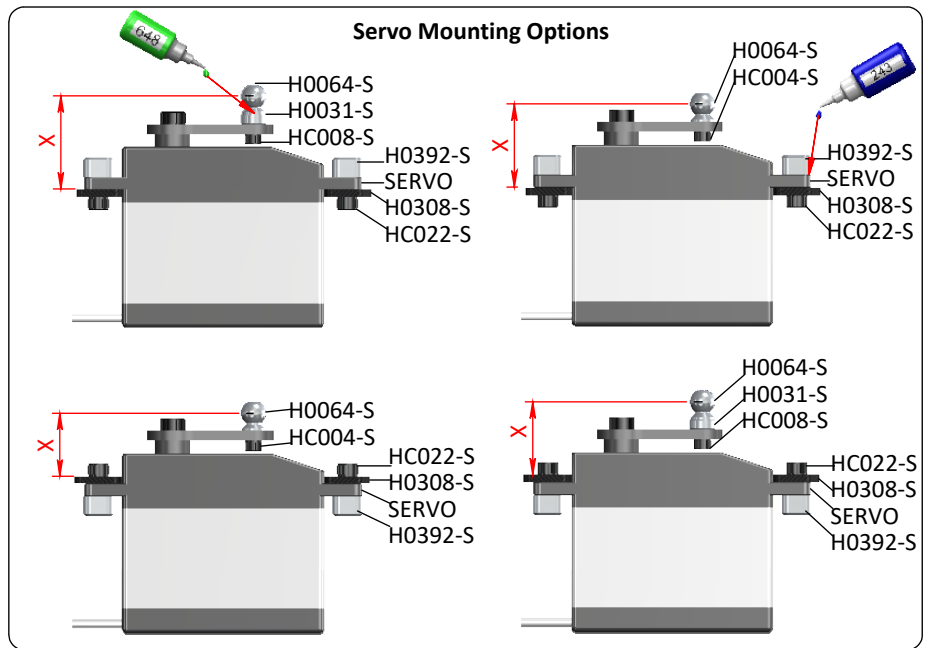
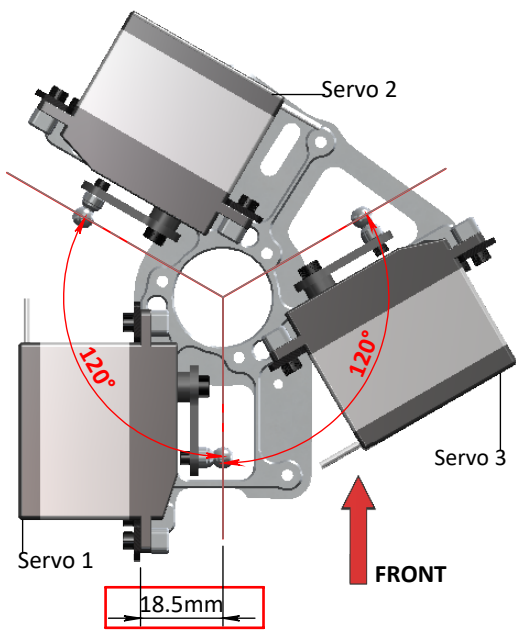
**Installation Of The Swashplate Servos**

The distance between the center of the horn and the ball should be between **16-18 mm**). Select the carbon fiber servo mount that is suitable for the size of servos to be used.

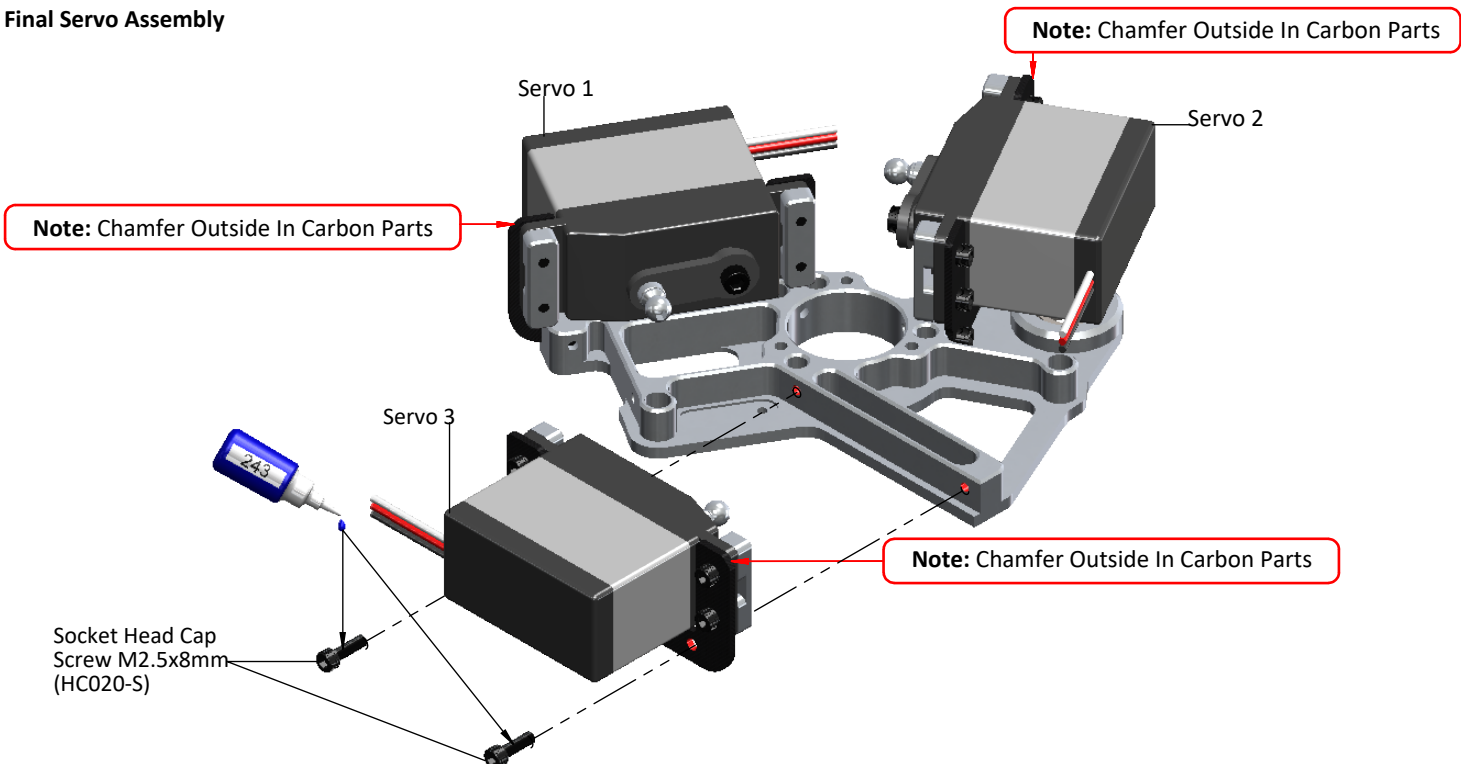


**Servo Mounting**

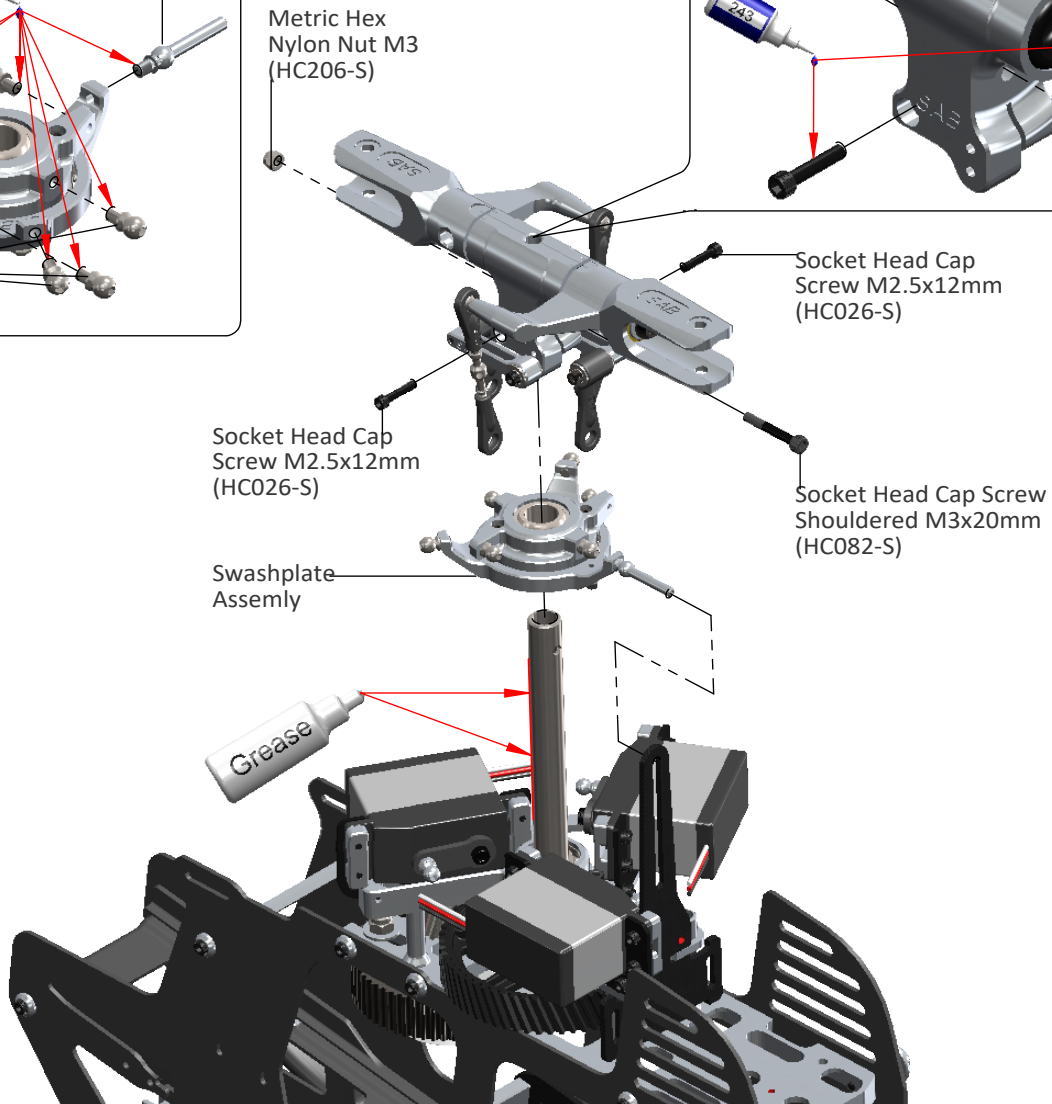
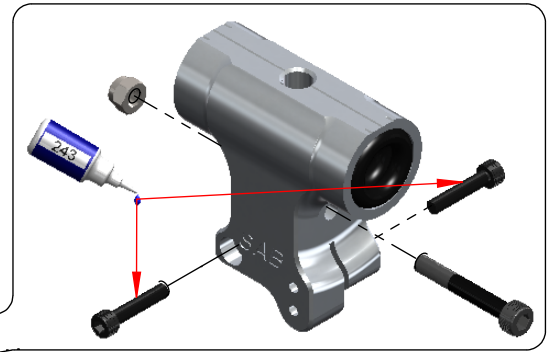
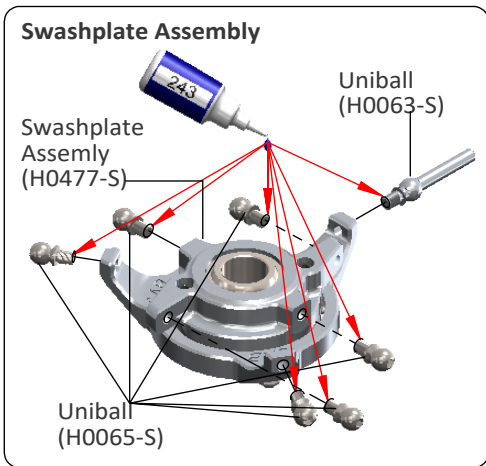
The servo linkages must be aligned correctly. In order to do this, you must choose from one of the options shown here. Figure 3 shows the installation of the servos at 120 degrees. Note that the distance between the carbon fiber servo mount and the center of the ball should be 18.5mm. Figure 4 shows 4 different mounting options, the distance "X" should be as close as possible to 18.5mm.



**Final Servo Assembly**

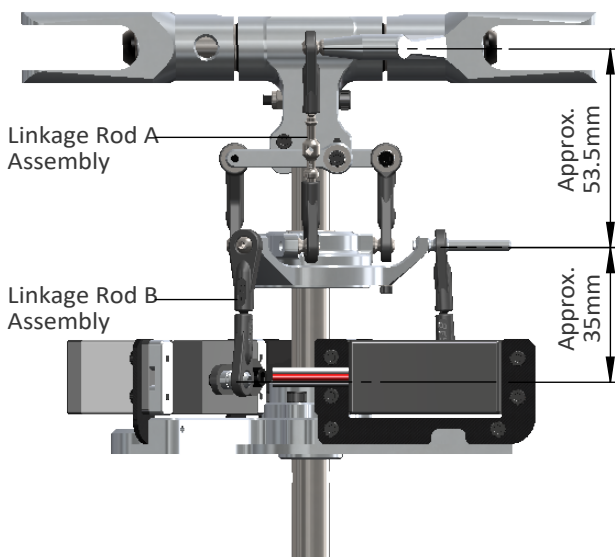




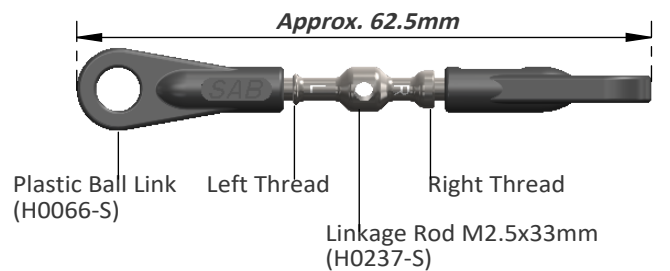


**Preliminary Head Setup**

Adjust the linkages as shown. You can change the tracking without disconnecting the plastic ball links by inserting a small tool through the rod hole and turning it.

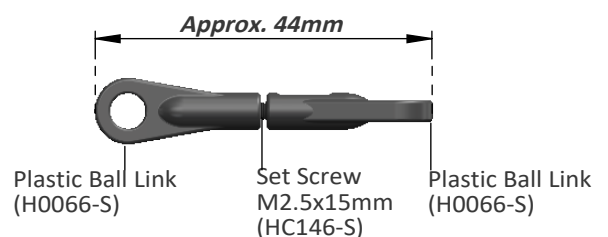


**Linkage Rod A Assembly . . . x2**



(Initial length for the rods from the swash plate to the Blade Grip.)

**Linkage Rod B Assembly . . . x3**



(Initial length for the rods from the servos to the swash plate.)



**TRANSMISSION SETUP**

It is important to choose the right reduction ratio to maximize efficiency based on your required flight performance. The Goblin has many possible reduction ratios at your disposal. It is possible to optimize any motor and battery combination. It is recommended to use wiring and connector appropriate for the currents generated in a helicopter of this class.

If you are using a head speed calculator which requires a main gear and pinion tooth count, use 206 teeth for main gear (this takes into account the two stage reduction) and the tooth count of your pulley as the pinion count.

Below is a list of available reduction ratios:

H0215-16-S-16T	Pinion = ratio 12.9:1	H0215-20-S-20T	Pinion = ratio 10.3:1
H0215-17-S-17T	Pinion = ratio 12.2:1	H0215-21-S-21T	Pinion = ratio 9.8:1
H0215-18-S-18T	Pinion = ratio 11.5:1	H0215-22-S-22T	Pinion = ratio 9.4:1
H0215-19-S-19T	Pinion = ratio 10.9:1	H0215-23-S-23T	Pinion = ratio 9:1
		H0215-24-S-24T	Pinion = ratio 8.5:1

These are pulleys for motors with a 6 mm shaft. Each pulley includes an adapter for motors with a 5 mm shaft.

**Some example configurations:**

<b>GOBLIN 570 SPORT CONFIGURATIONS</b>						
Performance	Battery	Motor	ESC	Pinion	RPM Max	Pitch
<b>GENERAL and 3D</b>	<b>6S - 5500</b> (5000 / 5500)	Kontronik Pyro 650-1030	EDGE 130	<b>24T</b>	<b>2250</b>	<b>± 13</b>
			Jive 100LV HW 120A V4	<b>24T</b>	<b>2300</b>	
		Scorpion HKIII 4025-1100  X-NOVA 4025-1120	EDGE 130	<b>22T / 23T</b>	<b>2300 / 2400</b>	
			Jive 100LV HW 120A V4	<b>21T / 22T</b>		
<b>3D and HARD 3D</b>	<b>12S - 3200</b> (3000 / 3300)	Scorpion HKIII 4025-550  X-NOVA 4025-560	EDGE 120 HV	<b>22T / 23T / 24T</b>	<b>2400 / 2500 / 2600</b>	<b>± 13</b>
			Jive 120HV HW 130A V4	<b>21T / 22T / 23T</b>		
		Kontronik Pyro 650-620	EDGE 120 HV	<b>20T / 21T / 22T</b>	<b>2400 / 2500 / 2600</b>	
			Jive 120HV HW 130A V4	<b>19T / 20T / 21T</b>		

**Note:** Although the Goblin can fly at high RPM, for safety reasons we recommend not exceeding 2600 RPM.

### Motor Belt Tension

- Install the motor and pulley to the motor mount plate.
- Place the motor assembly in position.
- Compress the springs by pushing the motor towards the main shaft.
- At max compression, tighten one of the slide screws temporarily.
- Put the belt around the motor pulley first, then put it around the big pulley.
- Rotate the motor a few times by hand to allow the belt to site properly.
- Loosen up the slide screw; the springs will tension the belt.
- Help the springs by pulling the motor and tighten.
- The belt must be very tight.
- Make sure to tighten all screws and nuts.

Check for proper vertical alignment of the motor pulley. Simply turn the motor several times by hand in the direction of normal rotation (counter clock-wise when viewed from above) and check to see if the belt is aligned with the big pulley. If the belt is riding too high, simply loosen up the motor pulley and drop it a bit, if it is riding too low, loosen up the motor pulley and raise it a bit (Fig 1 - 2).

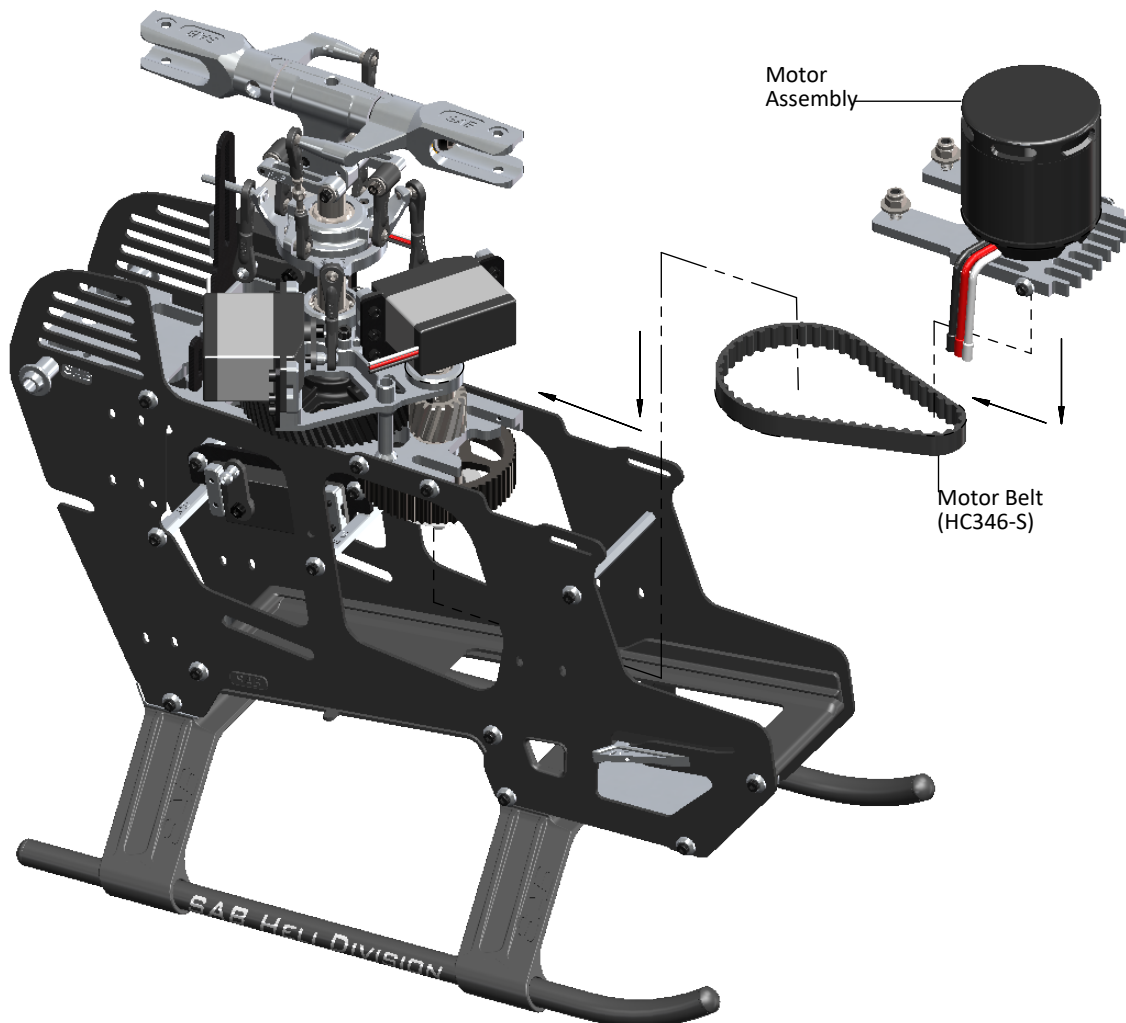


Fig. 1

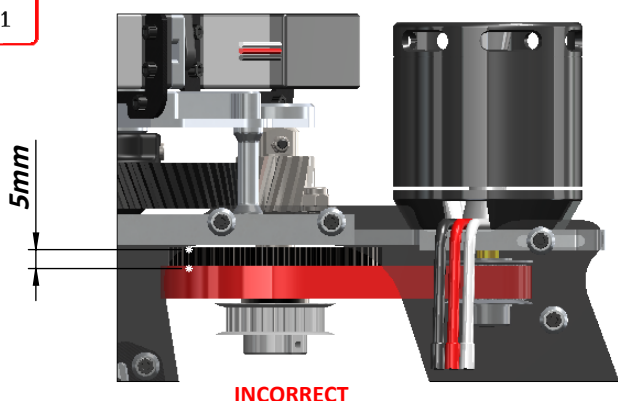
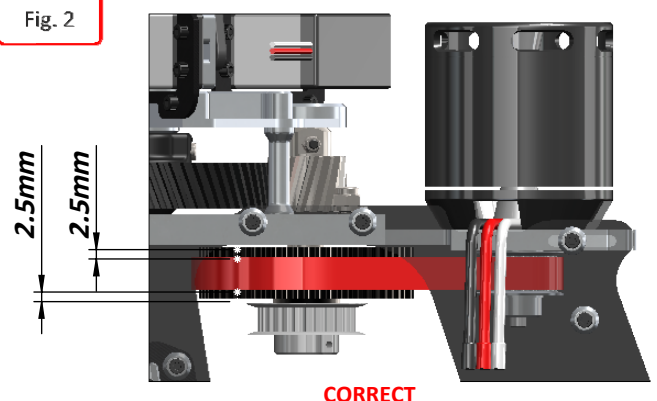


Fig. 2



**De-Burr The Side Frames**

We recommend de-burring the edges of the carbon parts in areas where electrical wires run. See Page 4.



**ESC Installation**

The electronic speed control (ESC) is installed in the front part of the helicopter.

You can easily fasten the ESC with cable ties as shown in figures 1 and 2. Take care of orient the closure of the ties as show in Figure 3.

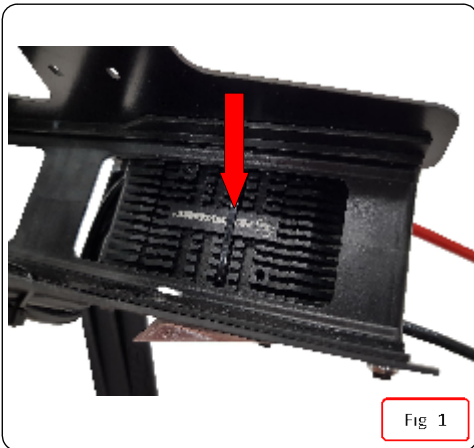


Fig 1

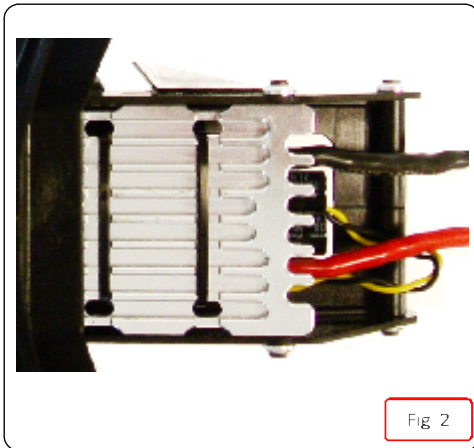


Fig 2

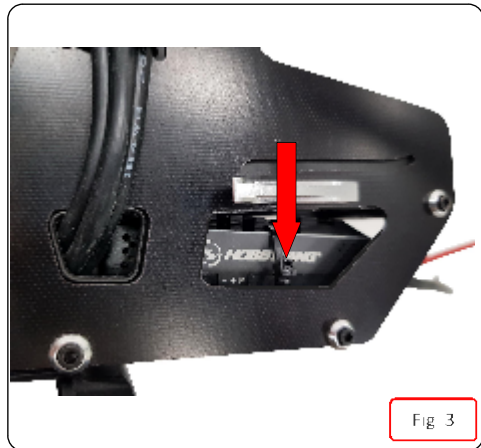
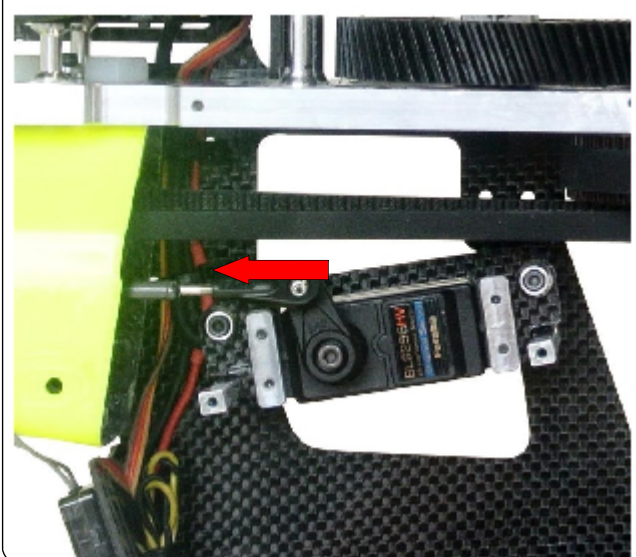
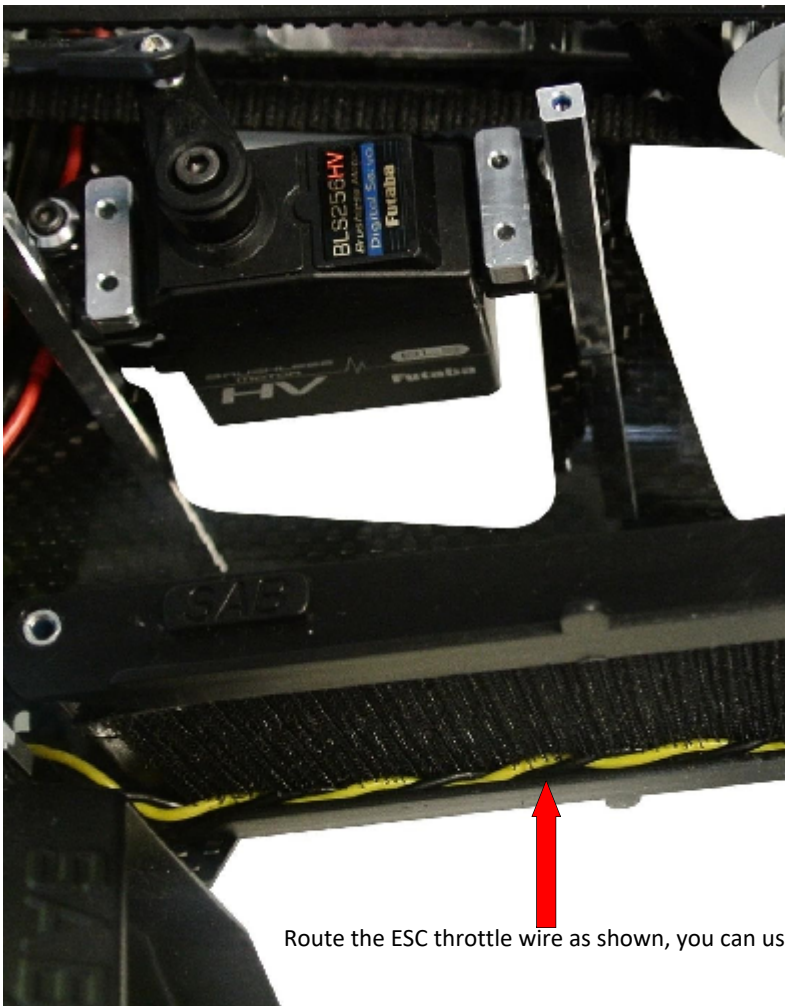


Fig 3

**Figure 4:** You can see the wiring for connecting the ESC to the central unit.

Use cable ties to fasten the wires as indicated by the arrows.



Route the ESC throttle wire as shown, you can use hot glue to keep the wire in place.

**FBL System Installation**

We recommend the use of a one unit flybarless system, i.e. Mini vBar, Microbeast, etc. However, a two unit flybarless system can also be installed.

For one unit systems, the unit is installed as shown in position 1. See Fig 1,2,3.

Position 2 and 3 can be used for RX System.

Two unit FBL systems can be installed as follows: control unit in position 1 and sensor in position 4 or vice-versa.

To obtain the position 4 use H0313 [Bag 8.1].

Fig. 1

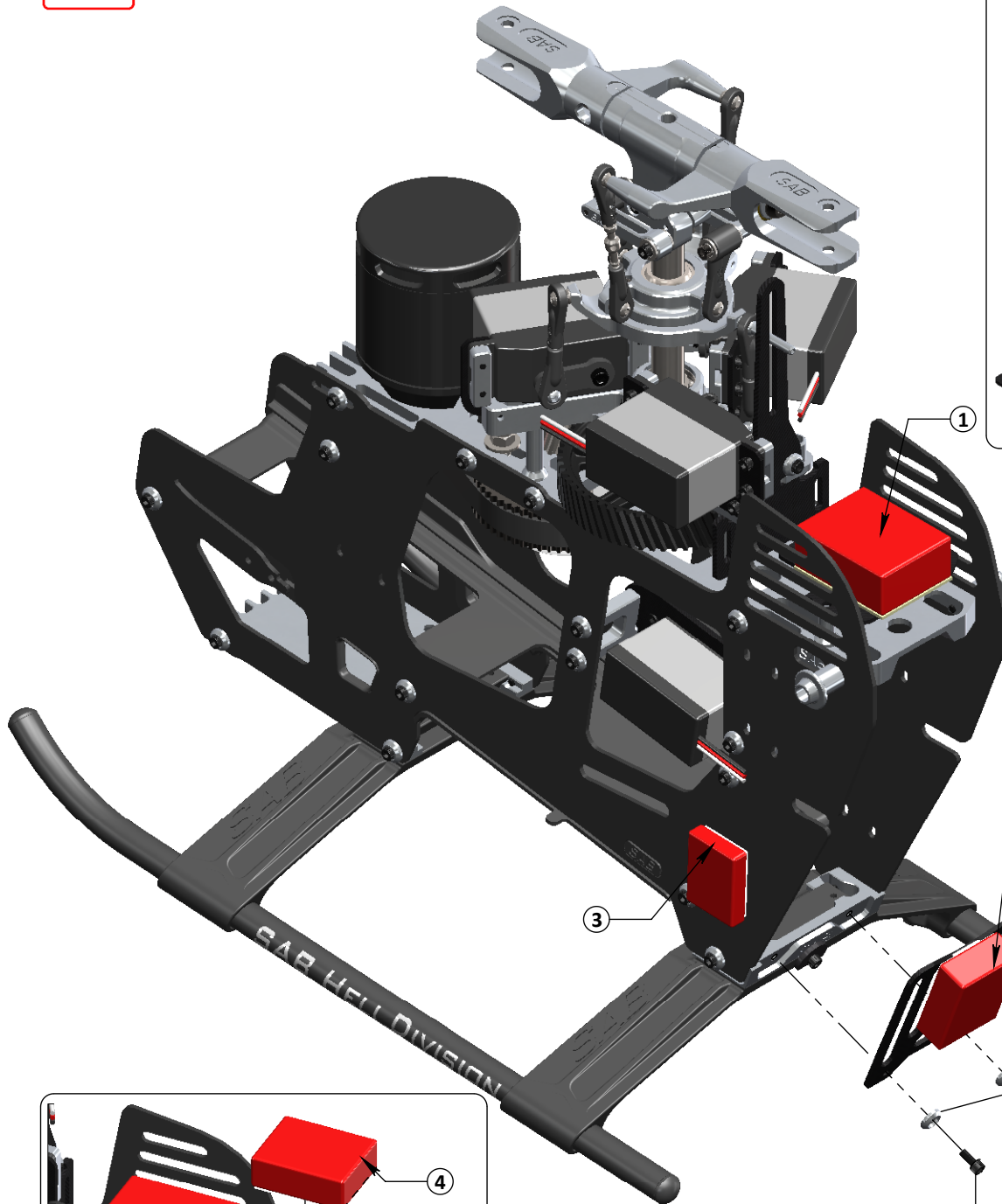

**FBL Assembly**

Fig. 2

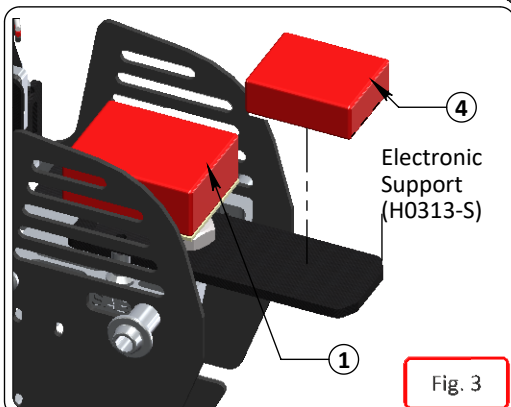
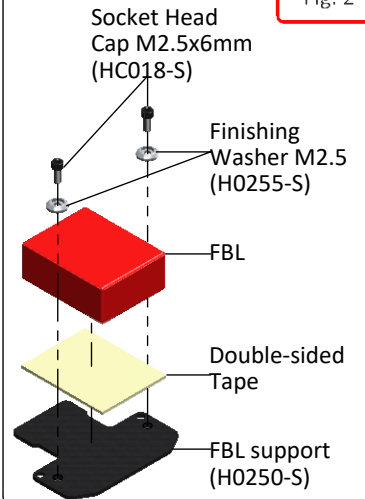
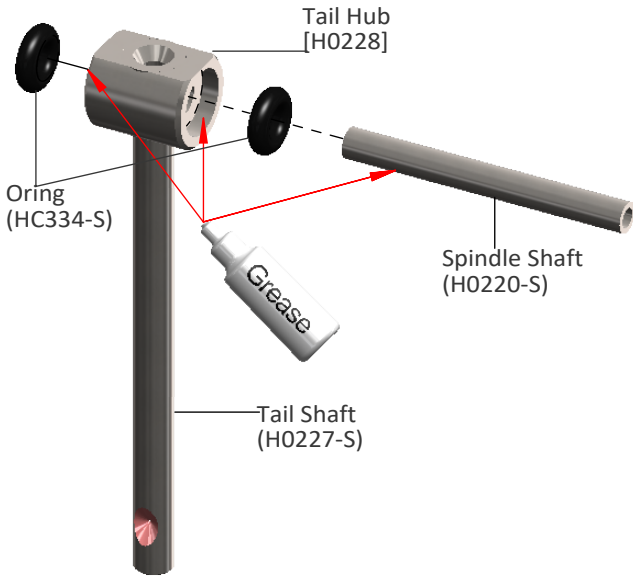


Fig. 3

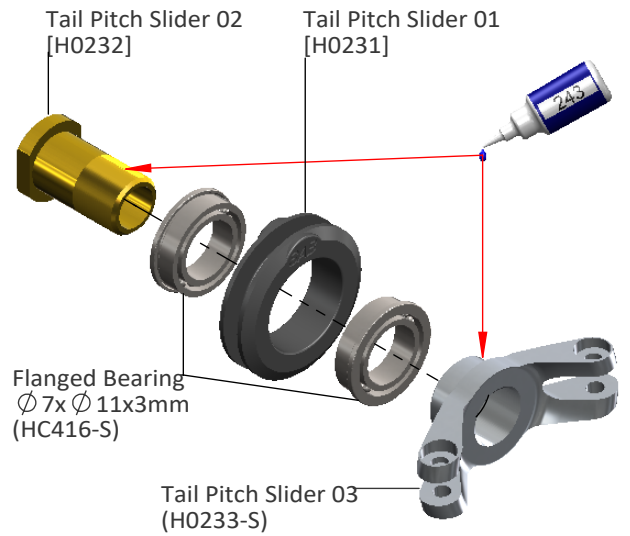


Tail Rotor Hub Assembly



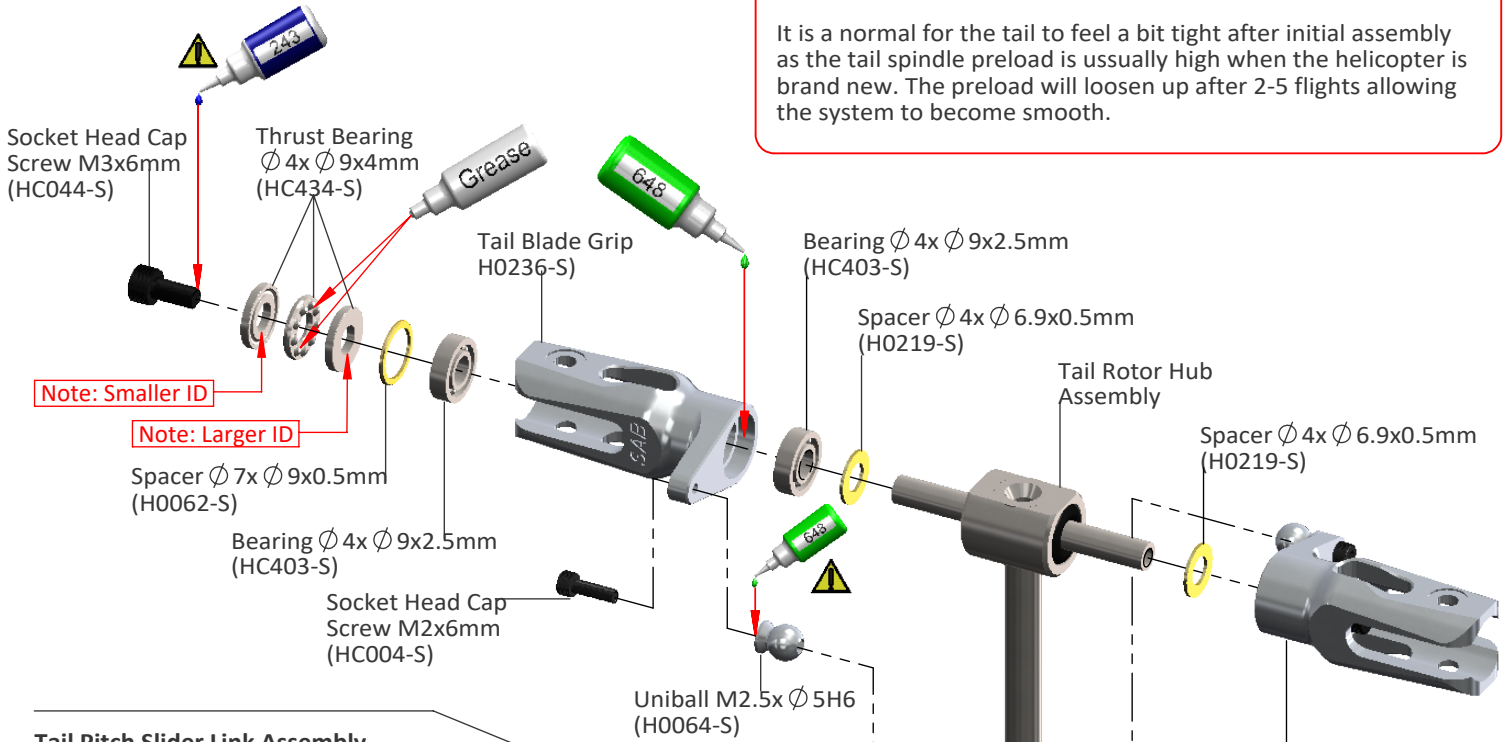
Tail Pitch Slider Assembly

Already assembled

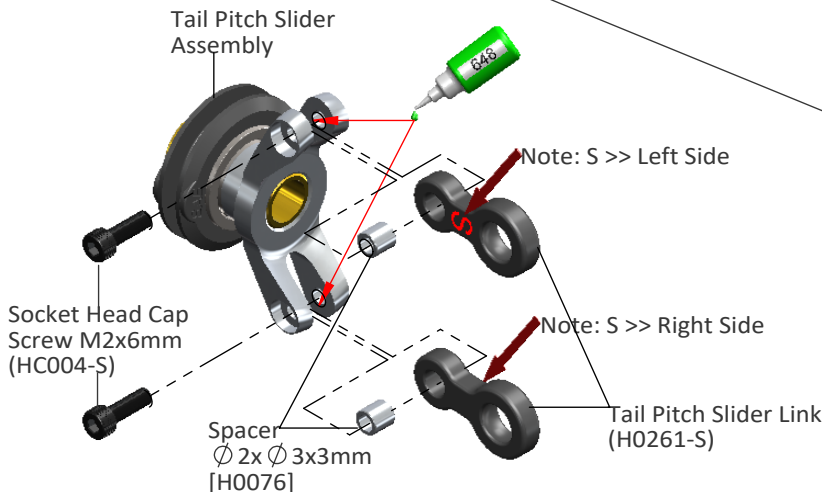


Note:

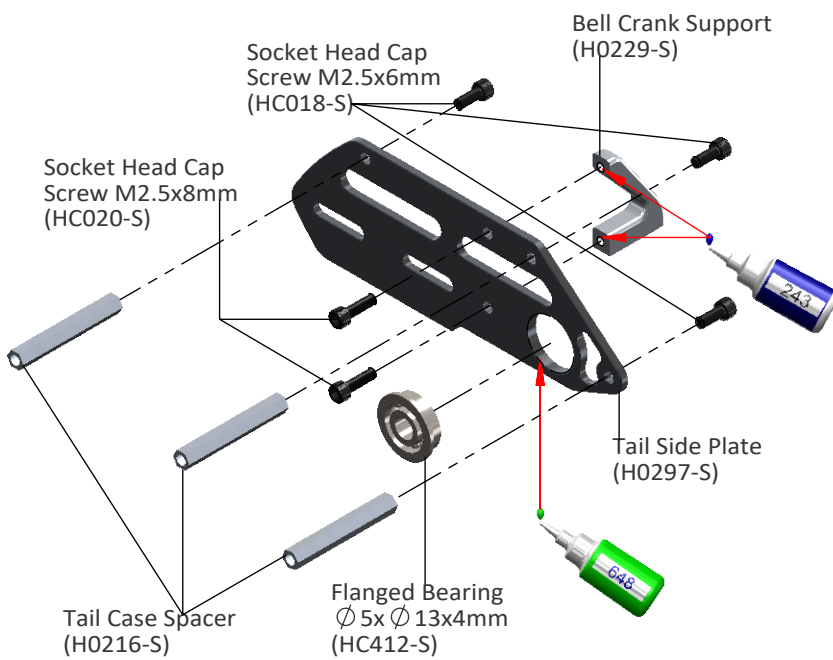
It is a normal for the tail to feel a bit tight after initial assembly as the tail spindle preload is usually high when the helicopter is brand new. The preload will loosen up after 2-5 flights allowing the system to become smooth.



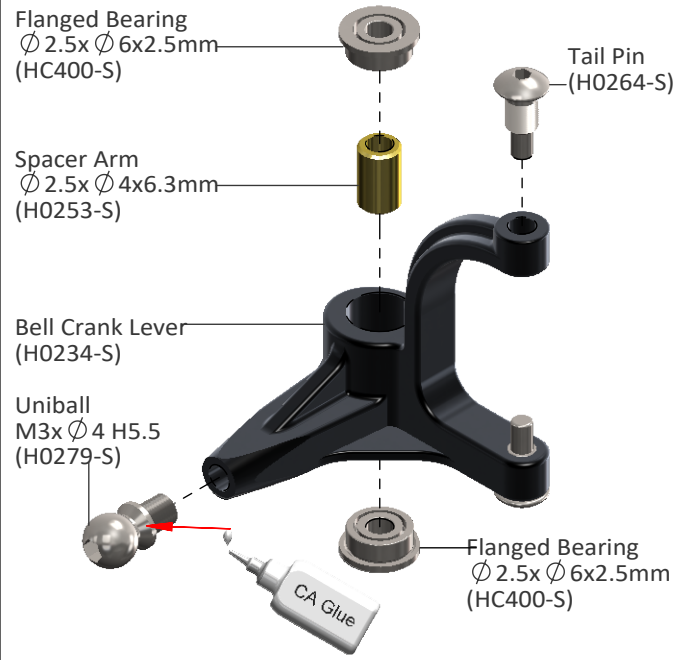
Tail Pitch Slider Link Assembly



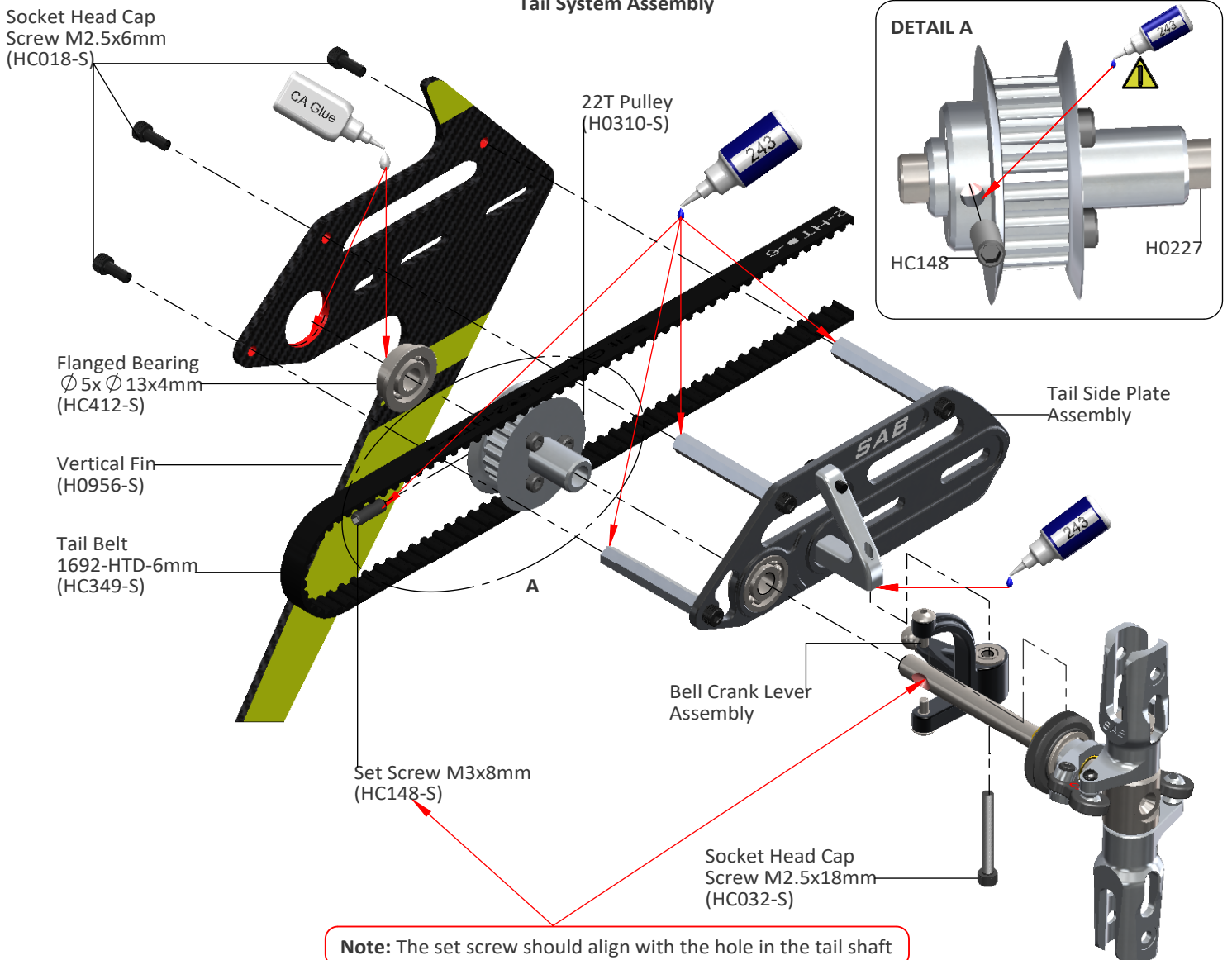
**Tail Side Plate Assembly**



**Bell Crank Lever Assembly**

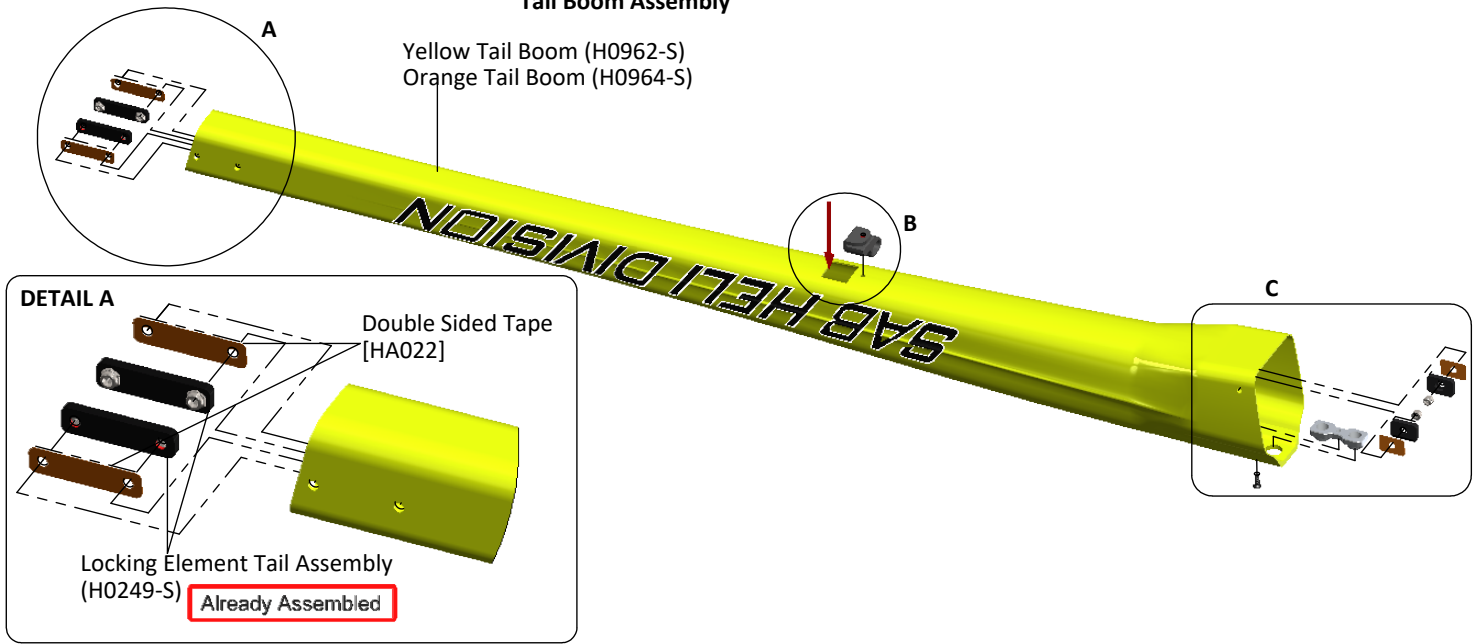


**Tail System Assembly**

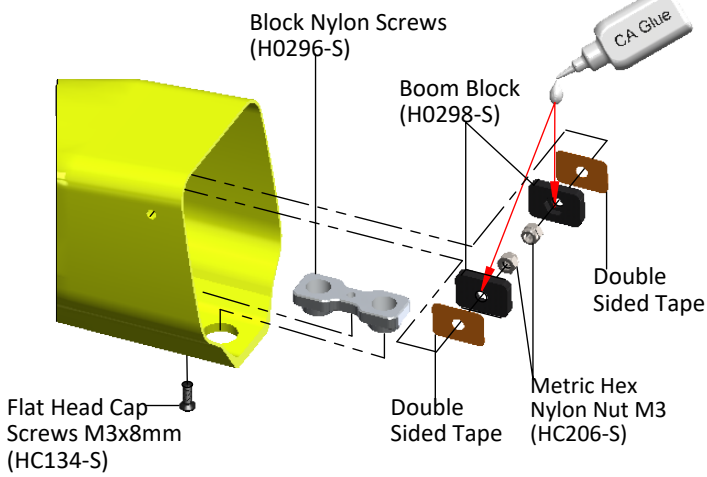


**Note:** The set screw should align with the hole in the tail shaft

Tail Boom Assembly



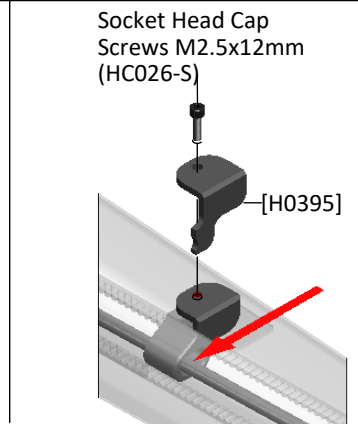
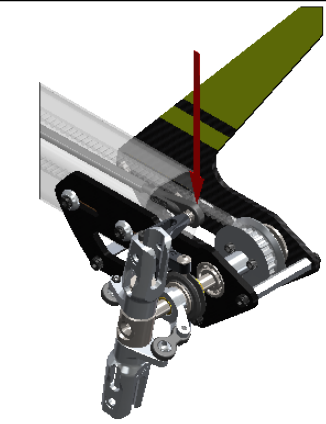
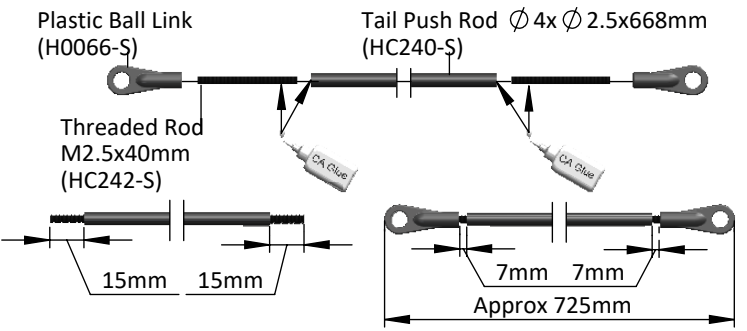
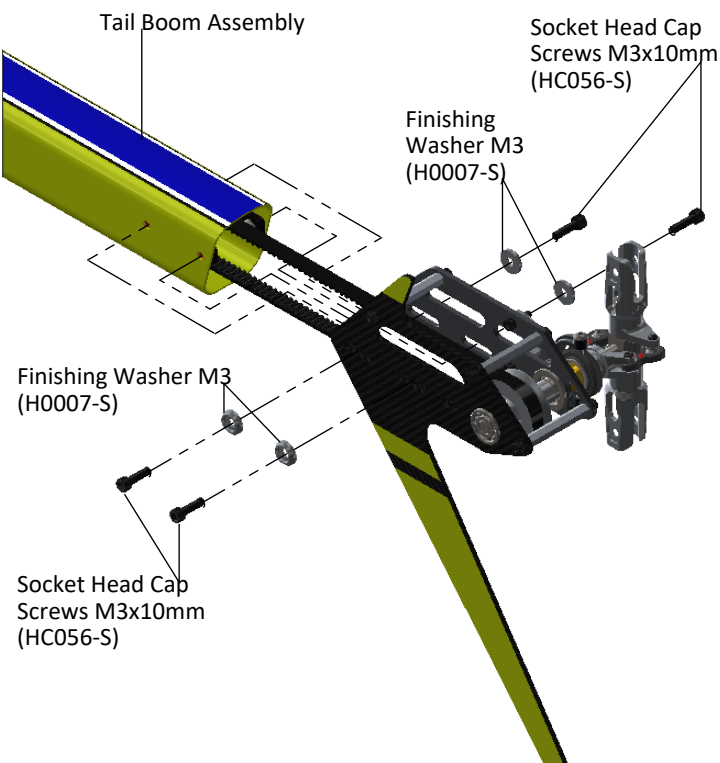
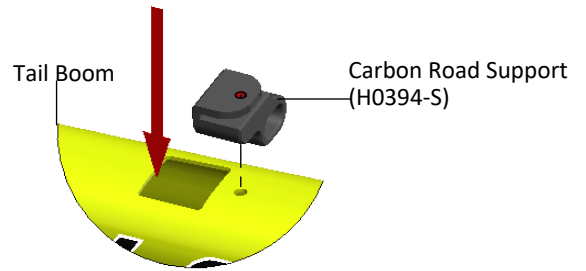
DETAIL C



DETAIL B

Install H0394-S On The Boom

Before mounting H0394 on the boom, we recommend to first tighten the M2.5 screw into the hole to open up the threads a bit. This will allow for easier installation.





**Installation Of The Boom**

- Insert the boom in place helping enlarging the frame ( Fig 1,2 ).
- Push the boom forward until the nylon bolts bottom out against the end of the slot on the boom.
- **Tighten the nylon bolts and only after tighten the two M3x10mm screws.**
- For additional safety, install the boom bolt safety lock (Fig 1).

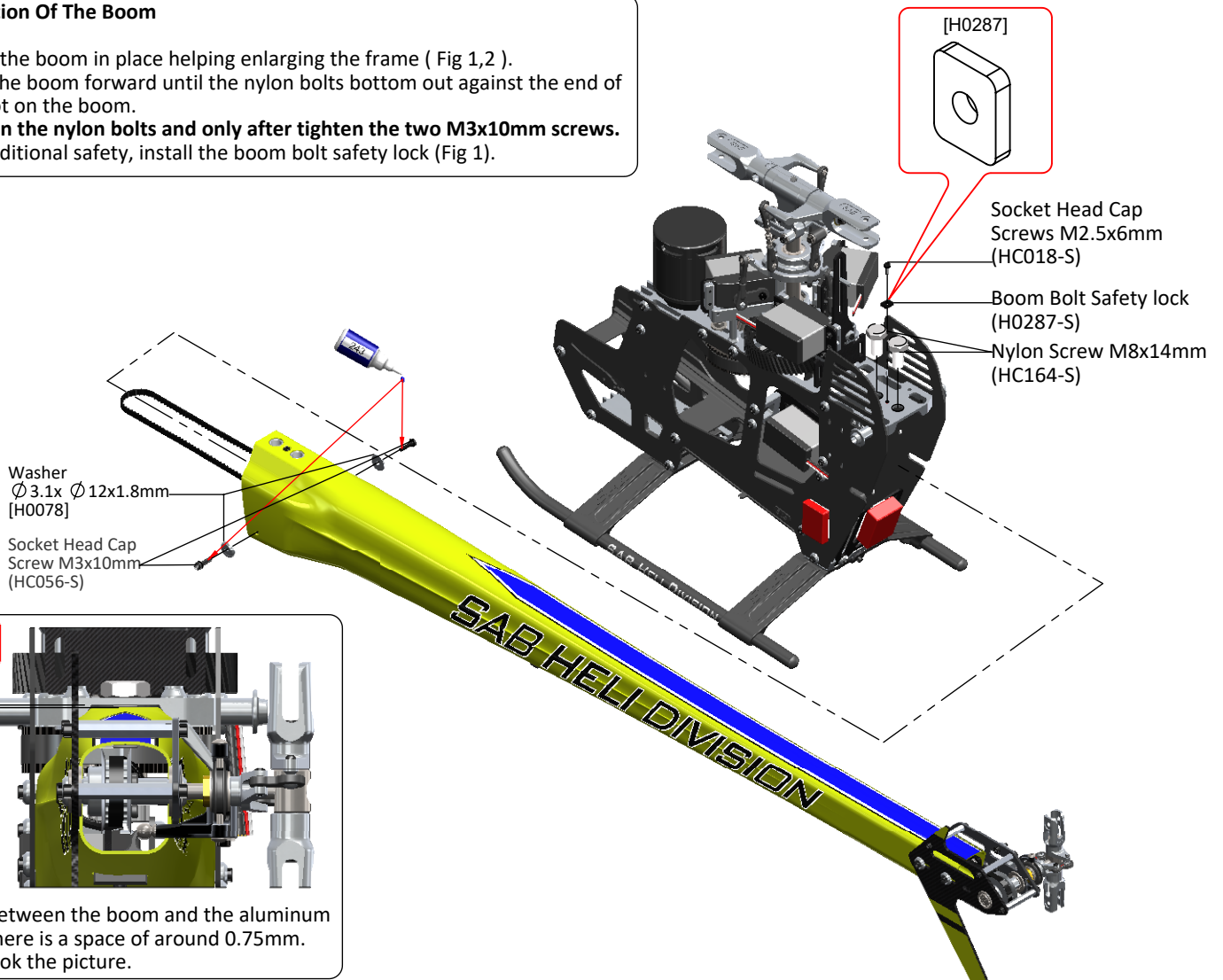
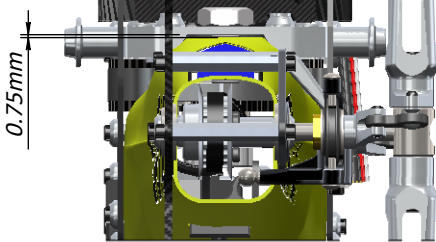


Fig. 2

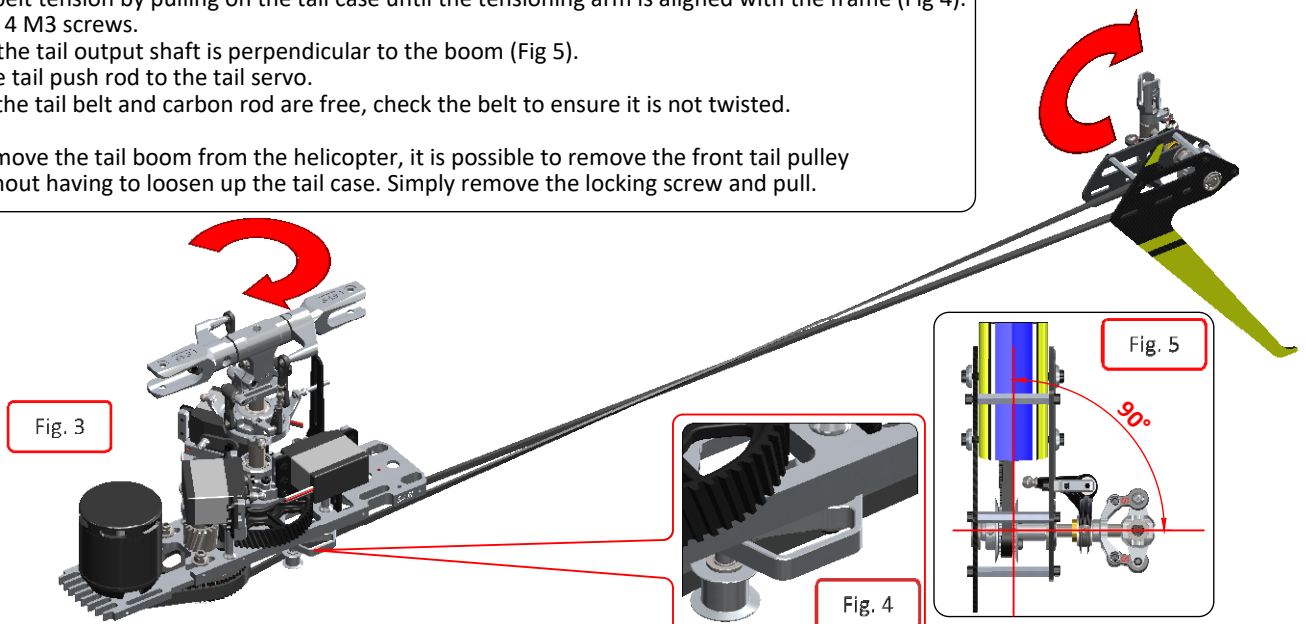


**Note:** Between the boom and the aluminum plate, there is a space of around 0.75mm. Look the picture.

**Tail Belt Tension**

- Make sure the boom is assembled and installed correctly.
- Loosen up the tail case by loosening the 4 M3 screws.
- Mount the tail belt on the front pulley making sure the direction of rotation is correct (Fig 3).
- Rotate the tail drive several times by hand.
- Load the spring by a rotation of 180° the tensioning arm
- Adjust the belt tension by pulling on the tail case until the tensioning arm is aligned with the frame (Fig 4).
- Tighten the 4 M3 screws.
- Check that the tail output shaft is perpendicular to the boom (Fig 5).
- Connect the tail push rod to the tail servo.
- Make sure the tail belt and carbon rod are free, check the belt to ensure it is not twisted.

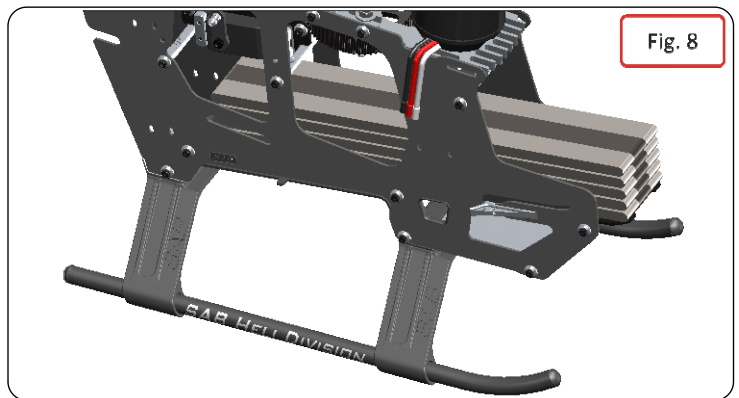
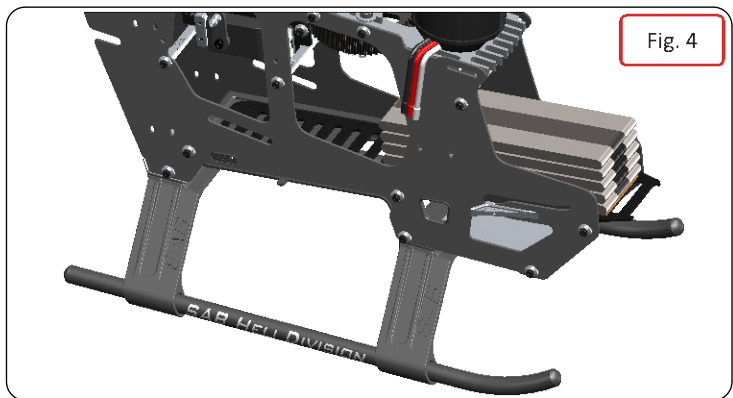
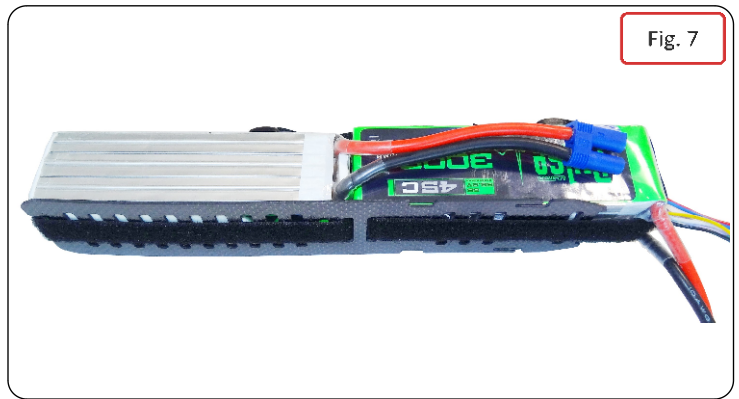
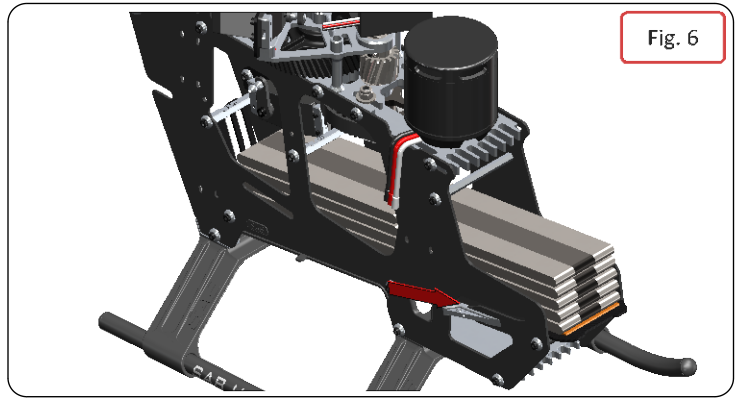
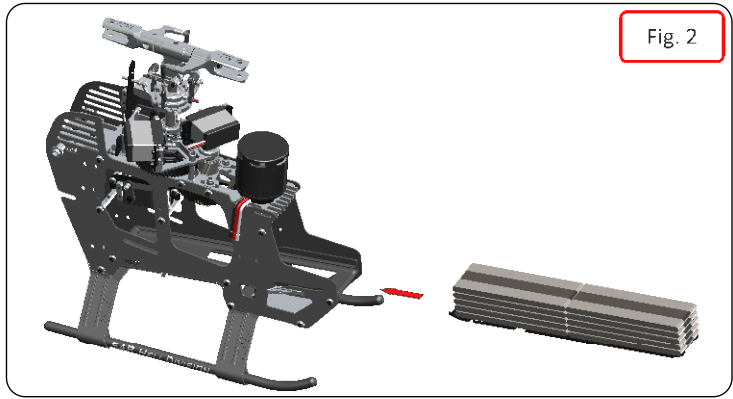
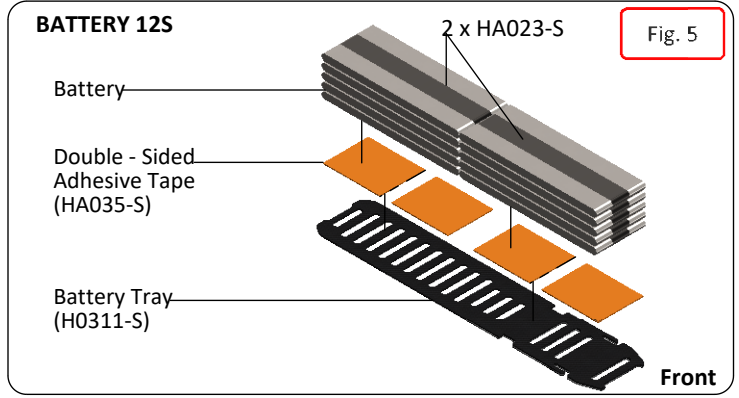
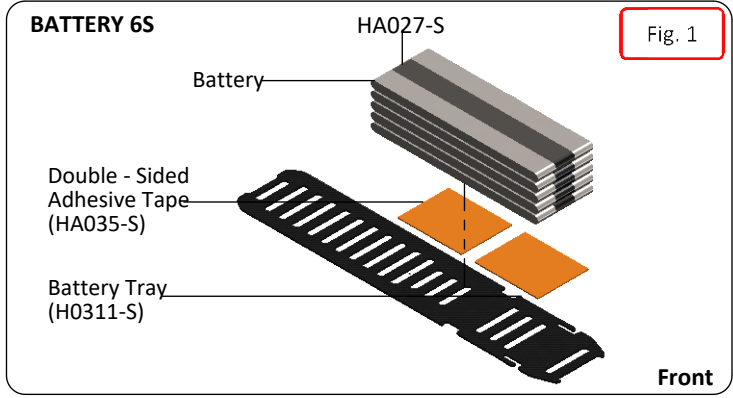
**NOTE:** To remove the tail boom from the helicopter, it is possible to remove the front tail pulley H0304-S without having to loosen up the tail case. Simply remove the locking screw and pull.



**Batteries**

- \* Follow the figure for assembly the battery. You can see 6S solution (fig 1,2,3,4 ) and 12S solution ( fig 5,6,7,8 ).
- \* With 12S configuration, it is recommended to orient down the wires in the front battery (Fig 7).
- \* Before permanently mounting the batteries onto the battery tray, check the ideal position for the best center of gravity.
- \* Before flight, make sure the battery is locked in place; the battery tray must be inside the slots on both sides!

- \* Battery 6S 5000/5500 mAh. Max dimension 50x60x200mm
- \* Battery 12S 2600/3300 mAh. Max dimension 50x45x280mm



**CANOPY**

- The canopy touches the frames on the Goblin, this is normal and expected as it is part of the design. To avoid canopy damage due to high frequency vibration, it is necessary to attach the adhesive foam tape HA006 to the canopy. [Bag 9] (Fig 2).
- Install the canopy grommets [Bag 9] as shown in Figure 2.
- Assembly the Edge Protection with a little super glue. [HA112] Figure.3
- The canopy locks in the front as shown by the arrow in Figure 4 and in the rear by the canopy screws H0248-S [Tray 2] (Fig 1).
- The process of installing the canopy is facilitated following the Figure 5.

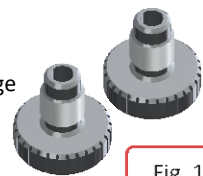
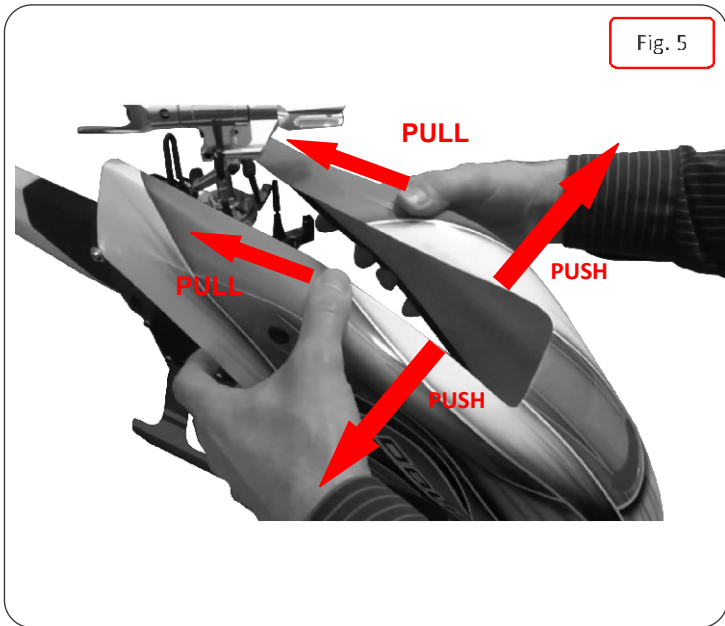


Fig. 1



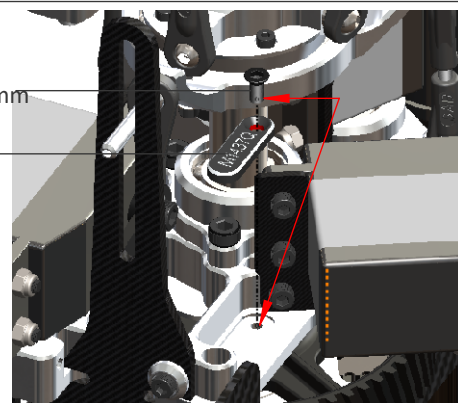
**Serial Number**

**Serial Number Tag**

In bag 10, you will find the serial number tag for your helicopter. Install the tag on the servo support plate as shown.

Please remember to register your product.( See page 1 )

- Flat Head Socket
- Cap Screws M2,5x5mm (HC128-S)
- Serial Number (H0286)



## OPERATIONS BEFORE FLIGHT

\*Set up the remote control and the flybarless system with utmost care.

\*It is advisable to test the correct settings of the remote and flybarless system without main blades or tail blades fitted.

\*Check that all wiring is isolated from the carbon/aluminum parts.  
It is good practice to protect them at the points where they are at most risk.

 \*Be sure of the gear ratio, verifying carefully the motor pulley in use. The forces acting on the mechanics increase enormously with increasing of rpm. Although the Goblin can fly at high rpm, for safety reasons we suggest to not exceed 2600rpm.

\*Check the correct tension of the tail belt through the belt tensioner.

\*Fit the main blades and tail blades. (Fig.1 and Fig.2)

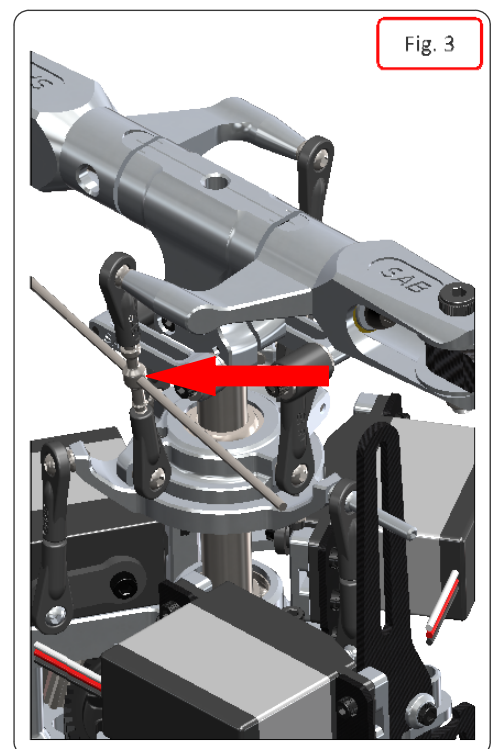
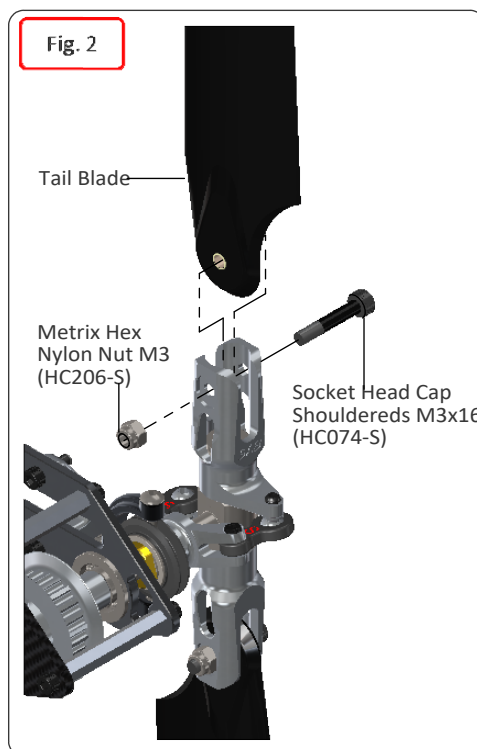
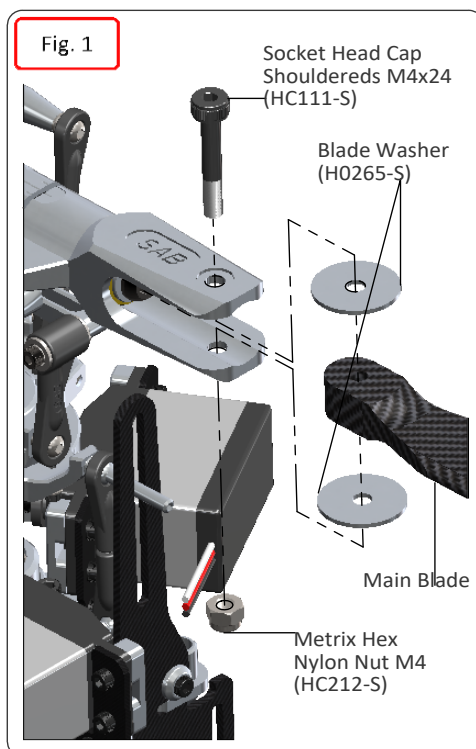
\*Please make sure the main blades are tight on the blade grips, you should be able to violently jerk the head in both directions and the blades should not fold. Failure to tighten the blades properly can result in a boom strike. To fold the blades for storage, it is advisable to loosen them.

\*Check the collective and cyclic pitch. For 3D flight, set about +/-13°.

\*It is important to check the correct tracking of the main blades.

\*On the Goblin, in order to correct the tracking, adjust the main link rod as shown in Fig.3. This is provided with a right/left thread system that allows continuous fine adjustments of the length of the control rod; for this adjustment it is not necessary to detach the ball link.

 \*Perform the first flight at a low headspeed, 2200 RPM. After this first flight, do a general check of the helicopter.  
Verify that all screws are correctly tightened.



## Maintenance

\*The lifespan of these components varies according to the type of flying. On average it is recommended to check these parts every 100 flights. In some instances, based on wear, these parts should be replaced every 200 flights.

\*The most stressed bearings are definitely those on the tail shaft. Check them frequently. All other parts are not particularly subject to wear.













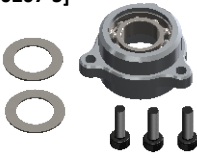
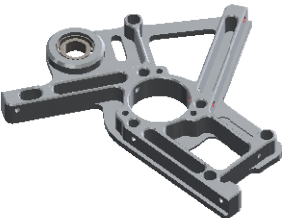
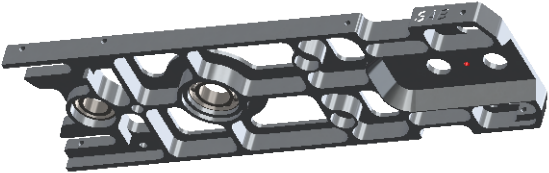
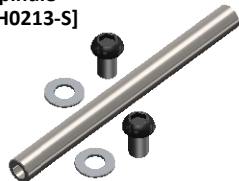
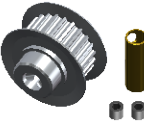
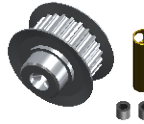
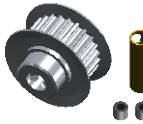



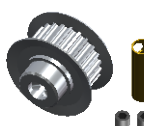
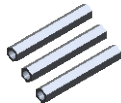
\*Periodically lubricate the tail slide movement and its linkages as well as the swash plate movement and its linkages.

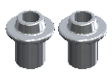

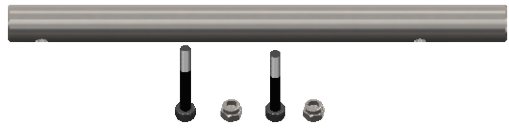

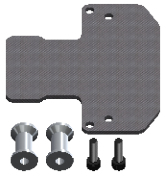







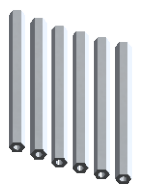


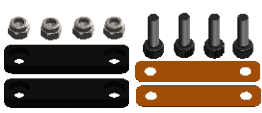




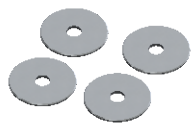

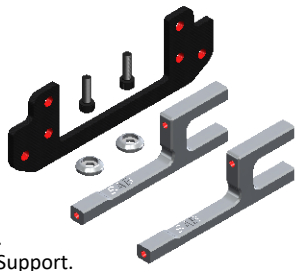
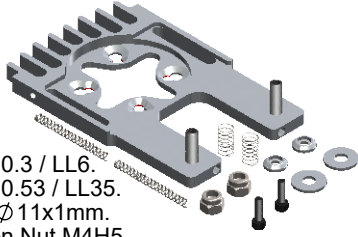
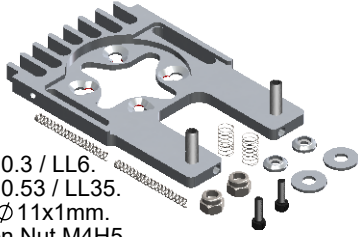

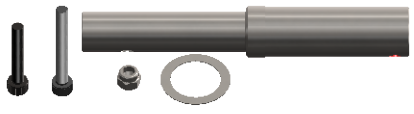
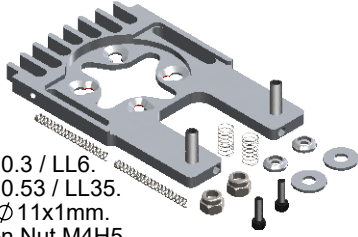
\*Lubricate the main gear with Dry-Fluid or Tri-Flow Synthetic grease, even though the gear is made of technopolymer, a high mineral based filler, it still requires some lubrication.


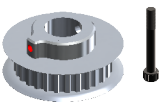
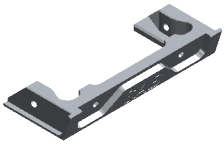



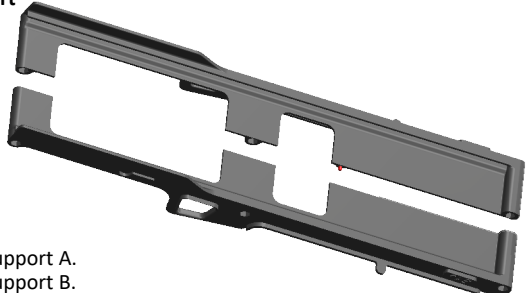
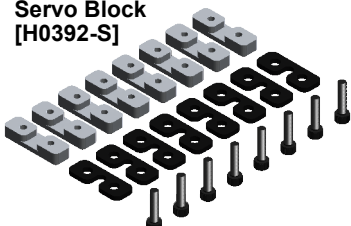





\*To ensure safety you should do a general inspection of the helicopter after each flight. You should check:

- Proper belt tension (motor belt and tail belt).
- Proper isolation of the wires from the carbon and aluminum parts.
- All screws remain tight.

After a crash, please inspect the carbon servo mounts H0308 to make sure they are not cracked or weakened. Failure to check and detect a possible crack could result in a future crash if a carbon servo mount breaks in flight.
























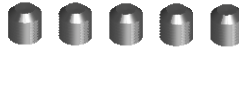

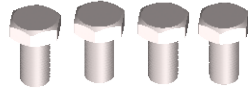

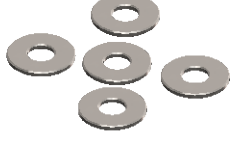




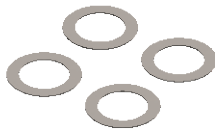
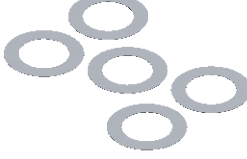
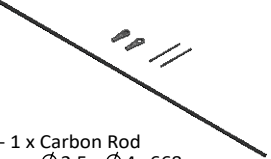
<p><b>Finishing Washer M3</b> [H0007-S]</p>  <p>- 10 x Finishing Washer M3.</p>	<p><b>Spacer <math>\varnothing 7 \times \varnothing 9 \times 0,5</math></b> [H0062-S]</p>  <p>- 4 x Spacer <math>\varnothing 7 \times \varnothing 9 \times 0,5 \text{mm}</math>.</p>	<p><b>Uniball Goblin M3<math>\varnothing 5 \text{H}18</math></b> [H0063-S]</p>  <p>- 2 x Uniball M3<math>\varnothing 5 \text{H}18</math>.</p>	<p><b>Uniball Goblin M2<math>\varnothing 5 \text{H}3.5</math></b> [H0064-S]</p>  <p>- 5 x Uniball M2. - 5 x Uniball Spacer. - 5 x Head Cap Screw M2x8. - 5 x Head Cap Screw M2x6.</p>	<p><b>Uniball Goblin M3<math>\varnothing 5 \text{H}3.5</math></b> [H0065-S]</p>  <p>- 5 x Uniball M3.</p>
<p><b>Plastic Ball Linkages</b> [H0066-S]</p>  <p>- 10 x Plastic Ball Linkages.</p>	<p><b>Carbon Servo Spacer</b> [H0075-S]</p>  <p>- 10 x Carbon Servo Spacer.</p>	<p><b>Washer <math>\varnothing 3,1 \times \varnothing 12 \times 1.8</math></b> [H0078-S]</p>  <p>- 4 x Washer <math>\varnothing 3,1 \times \varnothing 12 \times 1.8</math>.</p>	<p><b>Blade Grip</b> [H0202-S]</p>  <p>- 2 x Main Blade Grip. - 2 x Spacer <math>\varnothing 11 \times \varnothing 13.8 \times 0.5 \text{mm}</math>. - 4 x Bearing <math>\varnothing 8 \times \varnothing 14 \times 4 \text{mm}</math>. - 2 x Thrust Bearing <math>\varnothing 8 \times \varnothing 14 \times 4 \text{mm}</math>.</p>	
<p><b>Blade Grip Arm</b> [H0203-S]</p>  <p>- 2 x Main Blade Arm. - 2 x Head Cap Screw M3x8. - 2 x Uniball M3 <math>\varnothing 4 \text{H}3</math>.</p>	<p><b>Center Hub</b> [H0206-S]</p>  <p>- 1 x Center Hub. - 2 x Head Cap Screw M2.5x12. - 1 x Head Cap Screw M3x20. - 1 x Metrix Hex Nylon Nut M3.</p>	<p><b>Radius Arm HPS</b> [H0204-S]</p>  <p>- 2 x Radius Arm. - 2 x Spacer Arm 2.5x4x6.3. - 2 x Spacer Arm 2.5x4x3mm. - 2 x Uniball Radius Arm. - 8 x Flanged Bearing <math>\varnothing 2.5 \times \varnothing 6 \times 2.5</math>. - 2 x Washer 2.5x4x0.3mm. - 2 x Socket Head Cap Screw M2.5x15. - 2 x Socket Head Cap Screw M2.5x18.</p>	<p><b>Radius Plastic Arm</b> [H0205-S]</p>  <p>- 2 x Radius Plastic Arm.</p>	
<p><b>Bearing Support</b> [H0207-S]</p>  <p>- 1 x Bearing Support. - 1 x Bearing <math>\varnothing 10 \times \varnothing 19 \times 5</math>. - 3 x Head Cap Screws M3x10. - 2 x Washer <math>\varnothing 10 \times \varnothing 16 \times 0.1</math>.</p>	<p><b>Servo Support</b> [H0208-S]</p>  <p>- 1 x Servo Support. - 1 x Bearing <math>\varnothing 8 \times \varnothing 16 \times 5 \text{mm}</math>.</p>	<p><b>Main Structure</b> [H0212-S]</p>  <p>- 1 x Main Structure. - 1 x Bearing <math>\varnothing 8 \times \varnothing 16 \times 5 \text{mm}</math>. - 1 x Bearing <math>\varnothing 10 \times \varnothing 19 \times 5 \text{mm}</math>.</p>	<p><b>Spindle</b> [H0213-S]</p>  <p>- 1 x Spindle. - 2 x Button Cap Screw M6x10. - 2 x Washers <math>\varnothing 6.1 \times \varnothing 12 \times 1</math>.</p>	
<p><b>16T Pulley</b> [H0215-16-S]</p>  <p>- 1 x 16T Pulley. - 2 x Set Screws M4x4mm. - 1 x Bushing <math>\varnothing 5 \times \varnothing 6 \times 18 \text{mm}</math>.</p>	<p><b>17T Pulley</b> [H0215-17-S]</p>  <p>- 1 x 17T Pulley. - 2 x Set Screws M4x4mm. - 1 x Bushing <math>\varnothing 5 \times \varnothing 6 \times 18 \text{mm}</math>.</p>	<p><b>18T Pulley</b> [H0215-18-S]</p>  <p>- 1 x 18T Pulley. - 2 x Set Screws M4x4mm. - 1 x Bushing <math>\varnothing 5 \times \varnothing 6 \times 18 \text{mm}</math>.</p>	<p><b>19T Pulley</b> [H0215-19-S]</p>  <p>- 1 x 19T Pulley. - 2 x Set Screws M4x4mm. - 1 x Bushing <math>\varnothing 5 \times \varnothing 6 \times 18 \text{mm}</math>.</p>	<p><b>20T Pulley</b> [H0215-20-S]</p>  <p>- 1 x 20T Pulley. - 2 x Set Screws M4x4mm. - 1 x Bushing <math>\varnothing 5 \times \varnothing 6 \times 18 \text{mm}</math>.</p>
<p><b>21T Pulley</b> [H0215-21-S]</p>  <p>- 1 x 21T Pulley. - 2 x Set Screws M4x4mm. - 1 x Bushing <math>\varnothing 5 \times \varnothing 6 \times 18 \text{mm}</math>.</p>	<p><b>22T Pulley</b> [H0215-22-S]</p>  <p>- 1 x 22T Pulley. - 2 x Set Screws M4x4mm. - 1 x Bushing <math>\varnothing 5 \times \varnothing 6 \times 18 \text{mm}</math>.</p>	<p><b>23T Pulley</b> [H0215-23-S]</p>  <p>- 1 x 23T Pulley. - 2 x Set Screws M4x4mm. - 1 x Bushing <math>\varnothing 5 \times \varnothing 6 \times 18 \text{mm}</math>.</p>	<p><b>24T Pulley</b> [H0215-24-S]</p>  <p>- 1 x 24T Pulley. - 2 x Set Screws M4x4mm. - 1 x Bushing <math>\varnothing 5 \times \varnothing 6 \times 18 \text{mm}</math>.</p>	<p><b>Tail Spacer</b> [H0216-S]</p>  <p>- 3 x Tail Spacer.</p>

<p><b>Canopy Positioner</b> [H0217-S]</p>  <p>- 2 x Canopy Positioner.</p>	<p><b>Tail Spindle</b> [H0220-S]</p>  <p>- 1 x Tail Spindle. - 2 x Head Cap Screw M3x6.</p>	<p><b>Main Shaft</b> [H0222-S]</p>  <p>- 1 x Main Shaft. - 2 x Metrix Hex Nylon Nut M3H4. - 1 x Socket Head Cap Shoulder M3x20mm. - 1 x Socket Head Cap Shoulder M3x22mm.</p>	<p><b>Spacer Main Shaft</b> [H0223-S]</p>  <p>- 1 x Spacer Main Shaft. - 4 x Washer Ø10x Ø16x0.1mm.</p>	
<p><b>Sensor Support</b> [H0224-S]</p>  <p>- 2 x Sensor Support. - 1 x FBL Support. - 2 x Head Cap Screw M2.5x8.</p>	<p><b>Spacer Ø8x Ø12,5x0,5</b> [H0225-S]</p>  <p>- 2 x Spacer Ø8x Ø12,5x0,5.</p>	<p><b>Tail Rotor Shaft</b> [H0227-S]</p>  <p>- 1 x Tail Rotor Shaft. - 1 x Set Screw M3x8mm. - 1 x Tail Hub.</p>	<p><b>Bell Crank Support</b> [H0229-S]</p>  <p>- 1 x Bell Crank Support. - 2 x Head Cap Screw M2x8.</p>	<p><b>Tail Pitch Slider</b> [H0233-S]</p>  <p>- 1 x Tail Pitch Slider 01. - 1 x Tail Pitch Slider 02. - 1 x Tail Pitch Slider 03. - 2 x Flanged Bearing Ø7x Ø11x3mm.</p>
<p><b>Bell Crank Level</b> [H0234-S]</p>  <p>- 1 x Bell Crank level. - 2 x Tail Pin. - 2 x Flanged Bearing Ø2.5x Ø6x2.5mm. - 1 x Spacer Arm Ø2.5x Ø4x6.3mm. - 1 x Head Cap Screws M2.5x18. - 1 x Uniball M3x 4 H5.</p>	<p><b>Tail Blade Grip</b> [H0236-S]</p>  <p>- 2 x Tail Blade Grip. - 4 x Bearing Ø4x Ø9x2.5mm. - 2 x Spacer Ø7x Ø9x0.5mm. - 2 x Thrust Bearing Ø4x Ø9x4mm. - 2 x Socket Head Cap Screw M3x6mm. - 2 x Button Head Cap Screw M2x8mm.</p>	<p><b>Linkage HPS</b> [H0237-S]</p>  <p>- 2 x Linkage Rod M2.5x33mm. - 4 x Linkage Ball Link.</p>	<p><b>Spacer 54mm</b> [H0239-S]</p>  <p>- 6 x Spacer 54mm.</p>	<p><b>Canopy Locking</b> [H0248-S]</p>  <p>- 2 x Canopy Locking.</p>
<p><b>Canopy Locking</b> [H0248-S]</p>  <p>- 2 x Canopy Locking.</p>	<p><b>Locking Element Tail</b> [H0249-S]</p>  <p>- 2 x Locking Element Tail. - 4 x Metric Nylon Nut M3. - 4 x Head Cap Screw M3x10. - 2 x Double Side Tape.</p>	<p><b>Finishing Washer</b> [H0255-S]</p>  <p>- 10 x Finishing Washer M2.5.</p>	<p><b>Battery Block</b> [H0256-S]</p>  <p>- 1 x Battery Block. - 1 x Head Cap Screw M2.5x5.</p>	<p><b>Tail Linkage</b> [H0261-S]</p>  <p>- 2 x Tail Linkage. - 2 x Spacer. - 2 x Head Cap Screws M2x6.</p>
<p><b>Column</b> [H0263-S]</p>  <p>- 4 x Column.</p>	<p><b>Spacer Ø4x Ø18x1</b> [H0265-S]</p>  <p>- 4 x Spacer Ø4x Ø18x1mm.</p>	<p><b>Spacer Set</b> [H0287-S]</p>  <p>- 2 x Tail Grip Link Bushing. - 2 x Spacer Ø4x Ø7,50x0,5. - 2 x Spacer Ø8x Ø12,5x0,5. - 2 x Spacer Ø11x Ø13,8x0,5. - 2 x Spacer Arm 2,5x4 x6,3. - 2 x Spacer Arm 2,5x4x3.</p>	<p><b>CF Tail Servo Support</b> [H0289-S]</p>  <p>- 1 x CF Tail Servo Support. - 2 x Aluminum Tail Servo Support. - 2 x Socket Head Cap Screw M2.5x8mm. - 2 x Finishing Washer M2.5.</p>	<p><b>Motor Support</b> [H0291-S]</p>  <p>- 1 x Motor Support. - 2 x Spring de 5 / df 0.3 / LL6. - 2 x Spring de 3 / df 0.53 / LL35. - 2 x Washer Ø4.3x Ø11x1mm. - 2 x Metrix Hex Nylon Nut M4H5. - 2 x Socket Head Cap M2.5x8mm. - 2 x Finishing Washer M2.5mm. - 2 x Set Screw M4x15mm.</p>
<p><b>Motor Support</b> [H0291-S]</p>  <p>- 1 x Motor Support. - 2 x Spring de 5 / df 0.3 / LL6. - 2 x Spring de 3 / df 0.53 / LL35. - 2 x Washer Ø4.3x Ø11x1mm. - 2 x Metrix Hex Nylon Nut M4H5. - 2 x Socket Head Cap M2.5x8mm. - 2 x Finishing Washer M2.5mm. - 2 x Set Screw M4x15mm.</p>	<p><b>18T Pinion</b> [H0949-S]</p>  <p>- 1 x 18T Pinion. - 1 x Head Cap Screw M2.5x15. - 1 x Metric Nylon Nut M2.5. - 1 x Washer Ø8x Ø14x0.2.</p>	<p><b>Secondary Shaft</b> [H0294-S]</p>  <p>- 1 x Secondary Shaft. - 1 x Head Cap Screw M2.5x15mm. - 1 x Head Cap Screw M2.5x20mm. - 1 x Metrix Nylon Nut M2.5. - 1 x Washer Ø8x Ø14x0.2mm.</p>	<p><b>Motor Support</b> [H0291-S]</p>  <p>- 1 x Motor Support. - 2 x Spring de 5 / df 0.3 / LL6. - 2 x Spring de 3 / df 0.53 / LL35. - 2 x Washer Ø4.3x Ø11x1mm. - 2 x Metrix Hex Nylon Nut M4H5. - 2 x Socket Head Cap M2.5x8mm. - 2 x Finishing Washer M2.5mm. - 2 x Set Screw M4x15mm.</p>	

<p><b>One Way Pulley</b> [H0295-S]</p>  <ul style="list-style-type: none"> <li>- 1 x One Way Pulley.</li> <li>- 1 x One Way Bearing <math>\phi 10 \times \phi 14 \times 12</math>.</li> <li>- 2 x Bearing <math>\phi 10 \times \phi 15 \times 4</math>mm.</li> <li>- 2 x Washer <math>\phi 10 \times \phi 14 \times 0.1</math>mm.</li> </ul>	<p><b>Block Nylon Screws</b> [H0296-S]</p>  <ul style="list-style-type: none"> <li>- 1 x Block Nylon Screws.</li> <li>- 1 x Flat Head Cap Screw M3x8.</li> <li>- 2 x Nylon Screws M8x14.</li> </ul>	<p><b>Tail Side Plate</b> [H0297-S]</p>  <ul style="list-style-type: none"> <li>- 1 x Tail Side Plate.</li> </ul>	<p><b>28T Front Tail Pulley</b> [H0304-S]</p>  <ul style="list-style-type: none"> <li>- 1 x Front Tail Pulley.</li> <li>- 1 x Socket Head Cap Screws Shoudered M2.5x19mm.</li> </ul>
<p><b>Landing Gear Mount Rear</b> [H0306-S]</p>  <ul style="list-style-type: none"> <li>- 1 x Landing Gear Mount Rear.</li> </ul>	<p><b>Landing Gear Mount Front</b> [H0966-S]</p>  <ul style="list-style-type: none"> <li>- 1 x Landing Gear Mount Front.</li> </ul>	<p><b>Carbon Servo Mount</b> [H0308-S]</p>  <ul style="list-style-type: none"> <li>- 2 x Carbon Servo Mount.</li> <li>- 6 x Head Cap Screw M2.5x8mm.</li> </ul>	<p><b>Carbon Part Electric Support</b> [H0309-S]</p>  <ul style="list-style-type: none"> <li>- 1 x BEC/RX Support.</li> <li>- 1 x Sensor Support.</li> </ul>
<p><b>22T Tail Pulley</b> [H0310-S]</p>  <ul style="list-style-type: none"> <li>- 1 x Front Tail Pulley.</li> <li>- 1 x Set Screws M3x8mm.</li> </ul>	<p><b>Battery Tray</b> [H0311-S]</p>  <ul style="list-style-type: none"> <li>- 2 x Battery Tray.</li> <li>- 2 x Strap 20x440mm.</li> <li>- 1 x Strap 25x540mm.</li> </ul>	  <p>SAB HELI DIVISION</p>	
<p><b>Battery Tray Support</b> [H0312-S]</p>  <ul style="list-style-type: none"> <li>- 1 x Battery Tray Support A.</li> <li>- 1 x Battery Tray Support B.</li> </ul>	<p><b>Servo Block</b> [H0392-S]</p>  <ul style="list-style-type: none"> <li>- 8 x Servo Block.</li> <li>- 8 x Servo Spacer.</li> <li>- 8 x Head Cap Screws M2.5x10.</li> </ul>	<p><b>Carbon Road Support</b> [H0394-S]</p>  <ul style="list-style-type: none"> <li>- 1 x Carbon Road Support A.</li> <li>- 1 x Carbon Road Support B.</li> <li>- 1 x Head Cap Screws M2.5x12.</li> </ul>	
<p><b>Anti-Rotation Guide</b> [H0401-S]</p>  <ul style="list-style-type: none"> <li>- 1 x Anti-Rotation Guide.</li> <li>- 1 x Head Cap Screw M2.5x8.</li> <li>- 1 x Finishing Washer M2.5.</li> </ul>	<p><b>62T Main Gear</b> [H0948-S]</p>  <ul style="list-style-type: none"> <li>- 1 x 62T Main Gear .</li> <li>- 1 x Cap Screw Shouldered M3x20.</li> <li>- 1 x Metric Hex Nylon Nut M3H4.</li> </ul>	<p><b>SwashPlate</b> [H0477-S]</p>  <ul style="list-style-type: none"> <li>- 1 x Swashplate Assembly.</li> <li>- 1 x Uniball M3x4 <math>\phi 5</math>H18.</li> <li>- 6 x Uniball M3x4 <math>\phi 5</math>H3.</li> <li>- 7 x Socket Head Cap M2x5.</li> <li>- 1 x Bearing Rad. <math>\phi 30 \phi 37 \times 4</math>.</li> </ul>	
<p><b>Plastic F3C Landing Gear</b> [H0943-S]</p>  <ul style="list-style-type: none"> <li>- 2 x Plastic Landing Gear.</li> <li>- 1 x Head Cap Screw M2.5x8mm.</li> <li>- 1 x CF Block Landing Gear.</li> </ul>	<p><b>F3C Landing Gear Rod</b> [H0944-S]</p>  <ul style="list-style-type: none"> <li>- 2 x Landing Gear Rod.</li> <li>- 4 x Landing Gear Plug.</li> <li>- 2 x Set Screws M4x6mm.</li> </ul>		

<p><b>Tail Belt Tensioner</b> use for G500/G570 [H0946-S]</p>  <ul style="list-style-type: none"> <li>- 1 x Ilder Tensioner.</li> <li>- 1 x Column Tensioner.</li> <li>- 1 x Ilder Support.</li> <li>- 1 x Spring.</li> <li>- 2 x Flanged Bearing <math>\varnothing 3x \varnothing 7x3mm</math>.</li> <li>- 2 x Flanged Bearing <math>\varnothing 5x \varnothing 9x3mm</math>.</li> <li>- 1 x Washer <math>\varnothing 3.2x \varnothing 6x0.5mm</math>.</li> <li>- 1 x Head Cap Screw M3x12mm.</li> <li>- 1 x Head Cap Shoulder M2.5x25mm.</li> </ul>	<p><b>Main Frame</b> [H0955-S]</p>  <ul style="list-style-type: none"> <li>- 1 x Main Frame.</li> </ul>	<p><b>Tail Fin</b> [H0956-S]</p>  <ul style="list-style-type: none"> <li>- 1 x Tail Fin.</li> <li>- 1 x Sticker.</li> </ul>
<p><b>Yellow Tail Boom</b> [H0962-S]</p>   <ul style="list-style-type: none"> <li>- 1 x Yellow Tail Boom.</li> <li>- 2 x Nylon Screw M8x14mm.</li> <li>- 2 x Double Side Tape ( HA022) .</li> <li>- 2 x Washer <math>\varnothing 3.1x \varnothing 12x1.8mm</math>.</li> <li>- 2 x Locking Element Tail.</li> <li>- 6 x Metric Hex Nylon Nut M3.</li> <li>- 2 x Double Side Tape (HA028).</li> <li>- 2 x Socket Head Cap Screw M3x10mm.</li> </ul>	<p><b>Yellow Canopy</b> [H0963-S]</p>   <ul style="list-style-type: none"> <li>- 1 x Yellow Canopy.</li> <li>- 2 x Canopy Groumet.</li> <li>- 1 x Canopy Mouse.</li> <li>- 1 x Edge Protection.</li> </ul>	
<p><b>Orange Tail Boom</b> [H0964-S]</p>   <ul style="list-style-type: none"> <li>- 1 x Orange Tail Boom.</li> <li>- 2 x Nylon Screw M8x14mm.</li> <li>- 2 x Double Side Tape ( HA022) .</li> <li>- 2 x Washer <math>\varnothing 3.1x \varnothing 12x1.8mm</math>.</li> <li>- 2 x Locking Element Tail.</li> <li>- 6 x Metric Hex Nylon Nut M3.</li> <li>- 2 x Double Side Tape (HA028).</li> <li>- 2 x Socket Head Cap Screw M3x10mm.</li> </ul>	<p><b>Orange Canopy</b> [H0965-S]</p>   <ul style="list-style-type: none"> <li>- 1 x Orange Canopy.</li> <li>- 2 x Canopy Groumet.</li> <li>- 1 x Canopy Mouse.</li> <li>- 1 x Edge Protection.</li> </ul>	
<p><b>MAIN BLADES 570 WHITE</b> (570TBS)</p>  <ul style="list-style-type: none"> <li>- 2 x Main Blades 570 White.</li> </ul>	<p><b>TAIL BLADES 95 WHITE</b> (95TBS)</p>  <ul style="list-style-type: none"> <li>- 2 x Tail Blades 95 White.</li> </ul>	



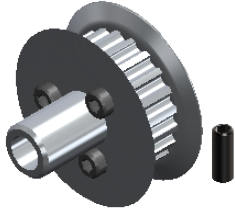
<p>[HC002-S]</p>  <p>- 5 x Socket Head Cap Screws M2x5mm.</p>	<p>[HC004-S]</p>  <p>- 5 x Socket Head Cap Screws M2x6mm.</p>	<p>[HC005-S]</p>  <p>- 5 x Button Head Cap Screws M2x5mm.</p>	<p>[HC008-S]</p>  <p>- 5 x Socket Head Cap Screws M2x8mm.</p>	<p>[HC014-S]</p>  <p>- 5 x Socket Head Cap Screws M2x12mm.</p>
<p>[HC018-S]</p>  <p>- 5 x Socket Head Cap Screws M2.5x6mm.</p>	<p>[HC020-S]</p>  <p>- 5 x Socket Head Cap Screws M2.5x8mm.</p>	<p>[HC022-S]</p>  <p>- 5 x Socket Head Cap Screws M2.5x10mm.</p>	<p>[HC026-S]</p>  <p>- 5 x Socket Head Cap Screws M2.5x12mm.</p>	<p>[HC028-S]</p>  <p>- 5 x Socket Head Cap Screws M2.5x15mm.</p>
<p>[HC032-S]</p>  <p>- 5 x Socket Head Cap Screws M2.5x18mm.</p>	<p>[HC033-S]</p>  <p>- 4 x Cap Shoulder M2.5x19mm. - 4 x Metrix Nylon Nut M2.5.</p>	<p>[HC044-S]</p>  <p>- 5 x Socket Head Cap Screws M3x6mm.</p>	<p>[HC056-S]</p>  <p>- 5 x Socket Head Cap Screws M3x10mm.</p>	<p>[HC074-S]</p>  <p>- 2 x Cap Shouldered M3x16. - 2 x Metric Nylon Nut M3H4.</p>
<p>[HC082-S]</p>  <p>- 5 x Socket Head Cap Shouldereds M3x20mm.</p>	<p>[HC083-S]</p>  <p>- 5 x Socket Head Cap Shouldereds M3x22mm.</p>	<p>[HC111-S]</p>  <p>- 5 x Socket Head Cap Shouldereds M4x24mm.</p>	<p>[HC122-S]</p>  <p>- 5 x Button Head Cap Screws M6x10mm.</p>	<p>[HC128-S]</p>  <p>- 5 x Flat Head Cap Screws M2.5x5mm.</p>
<p>[HC132-S]</p>  <p>- 5 x Flat Head Cap Screws M3x5mm.</p>	<p>[HC146-S]</p>  <p>- 5 x Set Screws M2.5x15mm.</p>	<p>[HC148-S]</p>  <p>- 5 x Set Screws M3x8mm.</p>	<p>[HC152-S]</p>  <p>- 5 x Set Screws 4x4mm.</p>	<p>[HC154-S]</p>  <p>- 5 x Set Screws 4x15mm.</p>
<p>[HC164-S]</p>  <p>- 4 x Vite Nylon Esa Caps M8x14mm.</p>	<p>[HC172-S]</p>  <p>- 10 x Washers Ø 2.5x Ø 4x0.3mm.</p>	<p>[HC184-S]</p>  <p>- 5 x Washers Ø 4.3x Ø 11x1mm.</p>	<p>[HC193-S]</p>  <p>- 10 x Washers Ø 6.1x Ø 12x1mm.</p>	<p>[HC200-S]</p>  <p>- 10 x Metric Hex Nylon Nuts M2.5H3.5.</p>
<p>[HC206-S]</p>  <p>- 10 x Metric Hex Nylon Nuts M3H4.</p>	<p>[HC212-S]</p>  <p>- 10 x Metric Hex Nylon Nuts M4 H5.</p>	<p>[HC228-S]</p>  <p>- 4 x Shim Washers Ø 8x Ø 14x0.2mm.</p>	<p>[HC234-S]</p>  <p>- 5 x Shims Washer Ø 10x Ø 16x0.1mm.</p>	<p>[HC240-S]</p>  <p>- 1 x Carbon Rod Ø 2.5 x Ø 4 x 668mm. - 2 x Plastic Ball Links. - 2 x Threaded Rods M2.5x40mm.</p>

<p><b>[HC316-S]</b></p>  <p>- 2 x Springs de 3 / df 0.53 / LL35. - 2 x Springs de 5 / df 0.3 / LL6.</p>	<p><b>[HC330-S]</b></p>  <p>- 4 x Damper Orings HC330. - 2 x Damper Orings HC334.</p>	<p><b>[HC346-S]</b></p>  <p>- 1 x Motor Belt 240-3GT-09.</p>	<p><b>[HC349-S]</b></p>  <p>- 1 x Tail Belt 1692-HTD-6mm.</p>
<p><b>[HC351-S]</b></p>  <p>- 5 x Flat Head Cap Screws M4x6mm.</p>	<p><b>[HC400-S]</b></p>  <p>- 4 x Flanged Bearings <math>\varnothing 2.5 \times \varnothing 6 \times 2.5</math>mm.</p>	<p><b>[HC403-S]</b></p>  <p>- 4 x Bearings <math>\varnothing 4 \times \varnothing 9 \times 2.5</math>mm.</p>	<p><b>[HC412-S]</b></p>  <p>- 4 x Flanged Bearings <math>\varnothing 5 \times \varnothing 13 \times 4</math>mm.</p>
<p><b>[HC416-S]</b></p>  <p>- 2 x Flanged Bearings <math>\varnothing 7 \times \varnothing 11 \times 2.5</math>mm.</p>	<p><b>[HC417-S]</b></p>  <p>- 2 x Bearings <math>\varnothing 8 \times \varnothing 14 \times 4</math>mm.</p>	<p><b>[HC419-S]</b></p>  <p>- 2 x Bearings <math>\varnothing 8 \times \varnothing 16 \times 5</math>mm.</p>	<p><b>[HC420-S]</b></p>  <p>- 2 x Bearings <math>\varnothing 10 \times \varnothing 15 \times 4</math>mm.</p>
<p><b>[HC422-S]</b></p>  <p>- 4 x Bearings <math>\varnothing 10 \times \varnothing 19 \times 5</math>mm.</p>	<p><b>[HC430-S]</b></p>  <p>- 2 x Bearings Rads <math>\varnothing 30 \times \varnothing 37 \times 4</math>mm.</p>	<p><b>[HC434-S]</b></p>  <p>- 2 x Thrust Bearings <math>\varnothing 4 \times \varnothing 9 \times 4</math>mm.</p>	<p><b>[HC437-S]</b></p>  <p>- 2 x Thrust Bearings <math>\varnothing 8 \times \varnothing 14 \times 4</math>mm.</p>
<p><b>[HC442-S]</b></p>  <p>- 1 x One Way Bearing <math>\varnothing 10 \times \varnothing 14 \times 12</math>mm.</p>	<p><b>[HA006-S]</b></p>  <p>- 1 x Canopy Mousse 80cm.</p>	<p><b>[HA023-S]</b></p>  <p>- 3 x Straps 20x440mm.</p>	<p><b>[HA027-S]</b></p>  <p>- 2 x Strap 25x540mm.</p>

## UPGRADES and ACCESSORIES

### Tail Pulley 21T [H0305-S]

You can use this tail pulley for improve the tail authority with low Headspeed (< 2400 rpm).



- 1 x Tail Pulley.
- 3 x Socket Head Cap Screws M2x12mm.
- 1 x Set Screws M3x8mm.

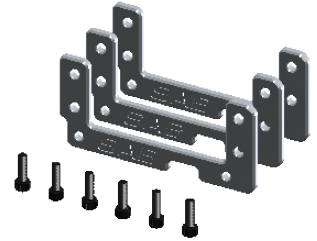
### Quick Release Canopy [H0321-S]



- 1 x Quick release canopy ( SET ).

### Aluminum Servo Support [H0397-S]

Alluminum servos support for the best precision of cyclic pith control.



- 2 x Aluminum Servo Support.
- 6 x Socket Head Cap Screws M2.5x8mm.

### Letter Sticker [HA070-S]



- 1 x Set Letter Sticker.

### Retaining Compound High Strength Bonding [HA115-S]



- 1 x Retaining Compound High Strength Bonding.

### Thread Locker Medium Strength [HA116-S]



- 1 x Thread Locker Medium Strength.

### SAB HELI DIVISION New Black T-shirt [HM025-S-M-L-XL-XXL]



- SAB HELI DIVISION New Black T-shirt.

### SAB HELI DIVISION Black Polo Shirt [HM027-S-M-L-XL-XXL]



- SAB HELI DIVISION Black Polo Shirt.

### SAB HELI DIVISION Black Hoodies [HM029-S-M-L-XL-XXL]



- SAB HELI DIVISION Black Hoodies.

### SAB TOOL KIT [HM054-S]



- 1 x Comfort Grip Hex tool 1.5mm.
- 1 x Comfort Grip Hex tool 2.0mm.
- 1 x Comfort Grip Hex tool 2.5mm.
- 1 x Comfort Grip Hex tool 3.0mm.
- 1 x SAB Tool Case.

### CAP [HM001, HM002, HM003]



- 1 x SAB HELI DIVISION CAP.

### SAB Goblin 500/570 Carry Bag [HM059]



- 1 x Carry Bag.

SAB H

BE ORIGINAL



- Carefully check your model before each flight to ensure it is airworthy.
- Consider flying only in areas dedicated to the use of model helicopters.
- Check and inspect the flying area to ensure it is clear of people obstacles.
- Rotor blades can rotate at very high speeds! Be aware of the danger they pose.
- Always keep the model at a safe distance from other pilots and spectators.
- Avoid maneuvers with trajectories towards a crowd.
- Always maintain a safe distance from the model.



[WWW.GOBLIN-HELICOPTER.COM](http://WWW.GOBLIN-HELICOPTER.COM)

SAB HELI DIVISION