

GOBLIN

HELICOPTER

MANUAL

GOBLIN 380

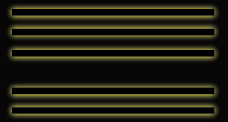

SAB HELI DIVISION

Goblin 380 Manual

Release 1.0 - January 2015

WORLD DISTRIBUTION

www.goblin-helicopter.com

For sales inquiries, please email: sales@goblin-helicopter.com

For information, please email: support@goblin-helicopter.com

Attention: If you are a consumer and have questions or need of assistance,
please contact the retailer where you made the purchased first.

EUROPEAN DISTRIBUTION

www.sabitaly.it

For sales inquiries, please email: sales@sabitaly.it

For information, please email: info@sabitaly.it

Attention: If you are a consumer and have questions or need of assistance,
please contact the retailer where you made the purchased first.

VERY IMPORTANT

Inside Box 4, you will find Bag 19. This bag contains your serial number tag. Please take a moment to register your kit online via our web site at:

<http://www.goblin-helicopter.com>

It is extremely important that you take a moment to register your helicopter with us. This is the only way to ensure that you are properly informed about changes to your kit, such as upgrades, retrofits and other important developments. SAB Heli Division cannot be held responsible for issues arising with your model and will not provide support unless you register your serial number.

To mount the serial number tag on your helicopter, please refer to page 7.

Thank you for your purchase, we hope you enjoy your new Goblin helicopter!

SAB Heli Division

INDEX

- | | | |
|------------------------------|---|---------------------------------------|
| 1 – Specifications | 7 – Assembling The Modules | 13 – Tail Assembly |
| 2 – Important Notes ⚠ | 8 – Installation of Swashplate Servos | 14 – Installation of the Boom, Canopy |
| 3 – Components and Box | 9 – Tail Servo Assembly | 15 – Battery |
| 4 – Carbon frame Assembly | 10 – Installation of The Motor | 16 – In flight ⚠ |
| 5 – Transmission Assembly | 11 – Installation of The ESC | 17 – Maintenance |
| 6 – Main Rotor Assembly | 12 – Installation of Flybarless Unit and RX | 18 – Exploded Views |
| | | 19 – Spare Parts |

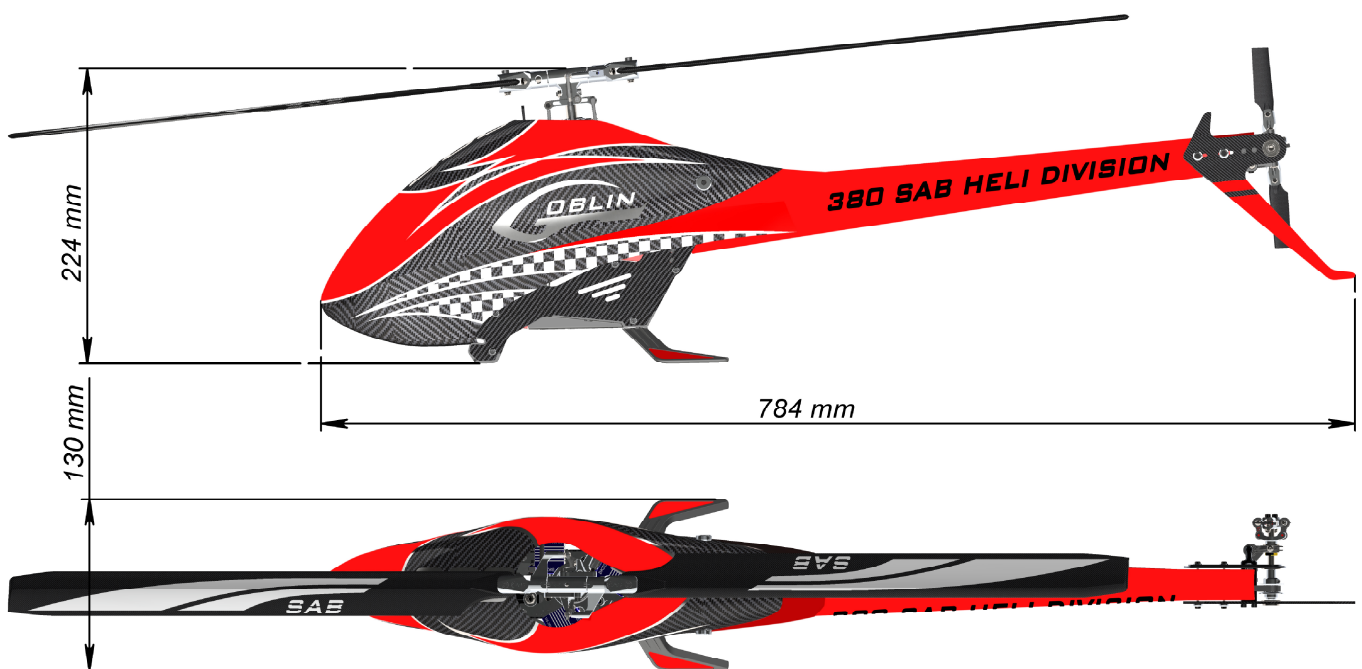
SPECIFICATIONS

- Main rotor diameter : 856mm.
- Main blade length : 380mm.
- Tail rotor diameter : 192mm.
- Tail blade length : 70mm.
- Main shaft diameter : 8mm.
- Tail shaft diameter : 5mm.
- Spindle diameter : 5mm.
- Motor size: Maximum 41mm diameter, maximum height 41mm.
- Battery compartment: 44x44x130mm.

IMPORTANT NOTES

- *This radio controlled helicopter is not a toy.
- *This radio controlled helicopter can be very dangerous.
- *This radio controlled helicopter is a technically complex device which has to be built and handled very carefully.
- *This radio controlled helicopter must be built following these instructions. This manual provides the necessary information to correctly assemble the model. It is necessary to carefully follow all the instructions.
- *Inexperienced pilots must be monitored by expert pilots.
- *All operators must wear safety glasses and take appropriate safety precautions.
- *A radio controlled helicopter must only be used in open spaces without obstacles, and far enough from people to minimize the possibility of accidents or of injury to property or persons.
- *A radio controlled helicopter can behave in an unexpected manner, causing loss of control of the model, making it very dangerous.
- *Lack of care with assembly or maintenance can result in an unreliable and dangerous model.

***Neither SAB Heli Division nor its agents have any control over the assembly, maintenance and use of this product. Therefore, no responsibility can be traced back to the manufacturer. You hereby agree to release SAB Heli Division from any responsibility or liability arising from the use of this product.**

SAFETY GUIDELINES

- *Fly only in areas dedicated to the use of model helicopters.
- *Follow all control procedures for the radio frequency system.
- *It is necessary that you know your radio system well. Check all functions of the transmitter before every flight.
- *The blades of the model rotate at a very high speed; be aware of the danger they pose and the damage they may cause.
- *Never fly in the vicinity of other people.

NOTES FOR ASSEMBLY

Please refer to this manual for assembly instructions for this model. Follow the order of assembly indicated. The instructions are divided into chapters, which are structured in a way that each step is based on the work done in the previous step. Changing the order of assembly may result in additional or unnecessary steps. Use thread lockers and retaining compounds as indicated. In general, each bolt or screw that engages with a metal part requires thread lock.

It is necessary to pay attention to the symbols listed below:



Important



⇒ Bag xx

Indicates that for this assembly phase you need materials that are in Bag xx.



Use retaining compound (eg Loctite 648)



Use retaining compound (eg Loctite 243)



Use CA Glue



Use Proper Lubricant

ADDITIONAL COMPONENTS REQUIRED

- *Electric Motor: 850 - 1000Kv:
Maximum diameter 41mm.
Maximum height 41mm.
Pinion shaft diameter 5 mm.
- *Speed controller: minimum 60A , extreme 3D Flight 70-90A.
- *Batteries: 6S-1800 mAh (1500 - 2600 mAh) .
- *1 flybarless 3 axis control unit.
- *Radio power system, if not integrated with the ESC.
- *3 micro cyclic servos.
- *1 mini (midi) tail rotor servo.
- *6 channel radio control system on 2.4 GHz.

(See configuration examples on page 14).

TOOLS, LUBRICANTS, ADHESIVES

- *Generic pliers.
- *Hexagonal driver, size 1.5,2,2.5mm.
- *5.5mm Socket wrench (for M3 nuts).
- *7mm Hex fork wrench (for M4 nuts).
- *Medium threadlocker (eg. Loctite 243).
- *Strong retaining compound (eg. Loctite 648).
- *Spray lubricant (eg. Try-Flow Oil).
- *Grease (eg. Microlube GL261).
- *Cyanoacrylate adhesive.
- *Pitch Gauge (for set-up).
- *Soldering equipment (for motor and ESC wiring).

Inside the main box there are:

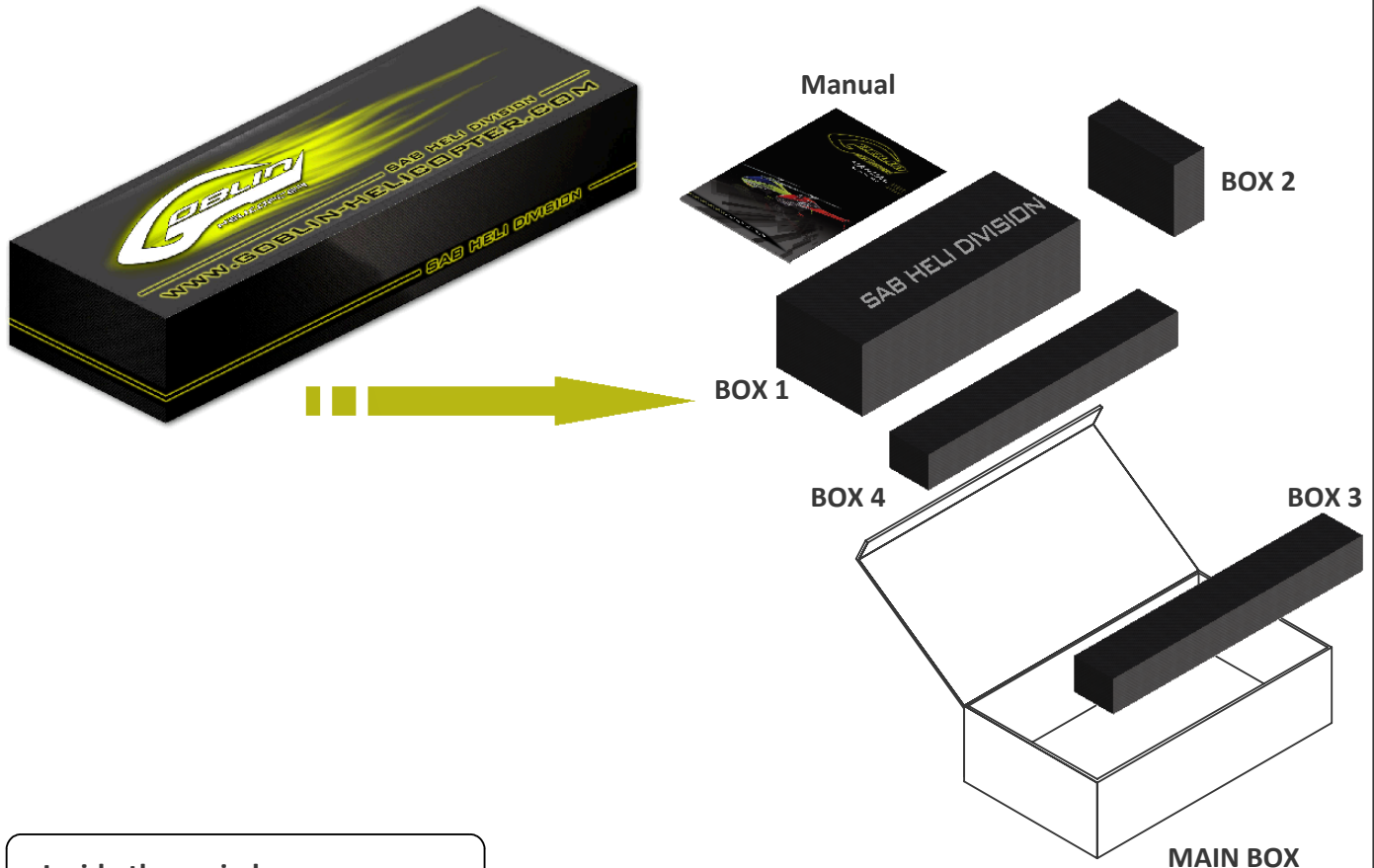

Inside the main box:

- Box 1: Canopy.
Frames.
Blade Holder.
Landing Gear.
Battery Support.
Tail Fin Assembly.
- Box 2: Combo Components (Optional).
- Box 3: Boom.
Carbon Rod.
Blades + Tail Blades.
- Box 4: Mechanical parts, Bags.

The assembly process is described in the following chapters. Each chapter provides you with the box and bag you will need for that chapter. The information is printed at the top of every page.

4-Carbon Frame



The manufacturing process of the carbon parts often leaves micro-burrs and sharp edges. We recommend de-burring the edges to minimize the risks of electrical wire cuts, etc. This is particularly important in the areas shown in red.

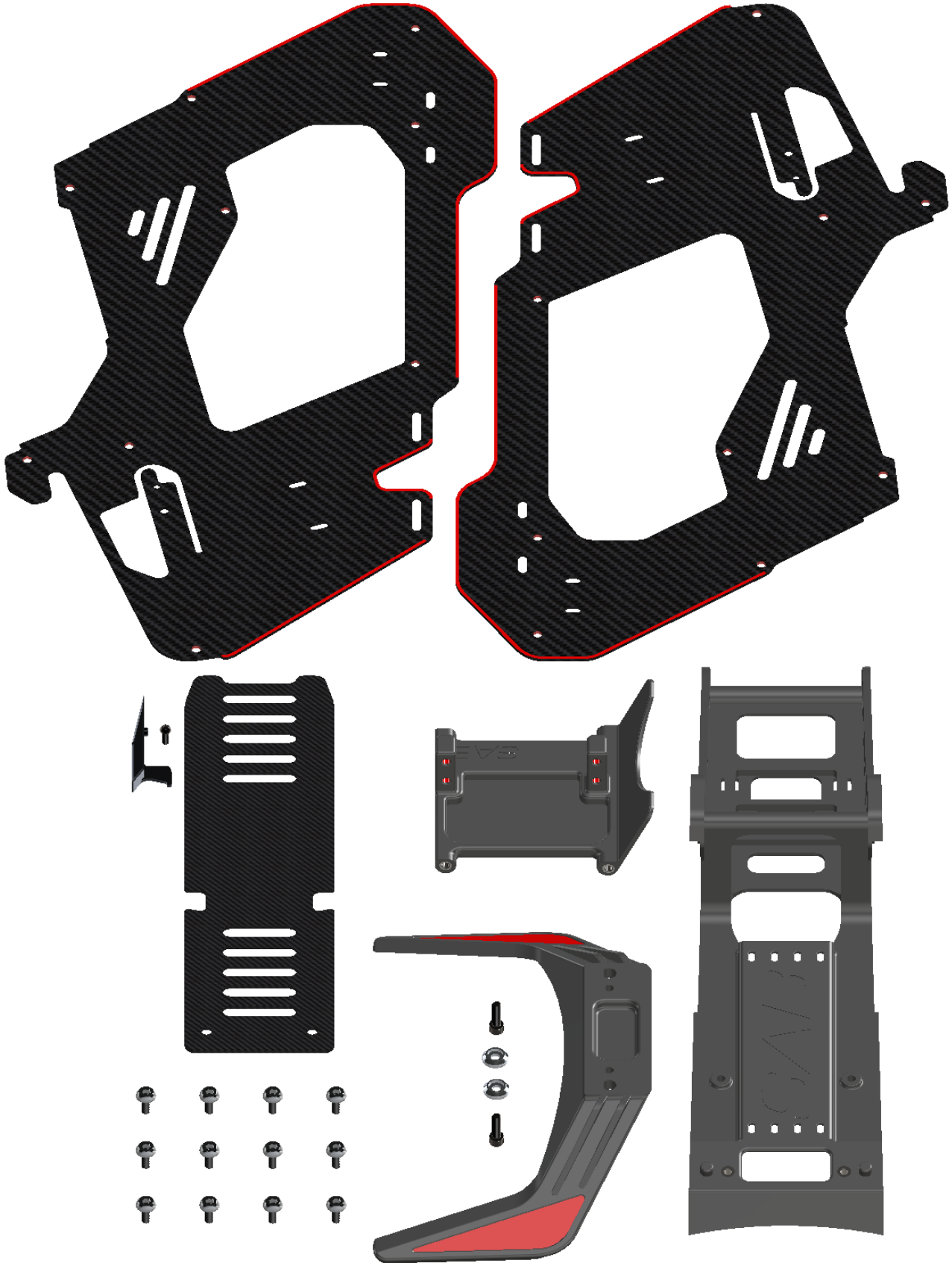

Left Main Frame Assembly

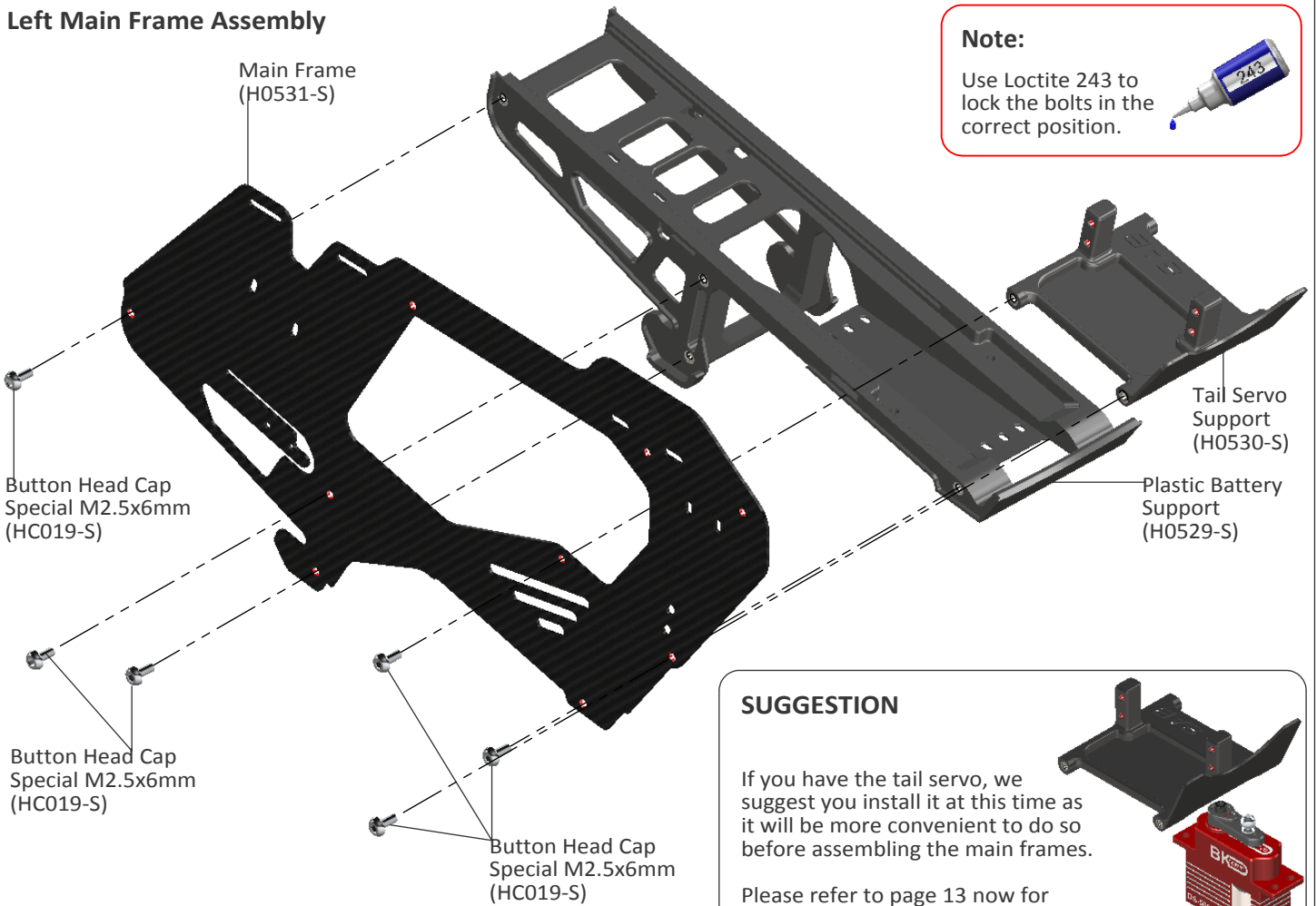

Note:

Use Loctite 243 to lock the bolts in the correct position.



SUGGESTION

If you have the tail servo, we suggest you install it at this time as it will be more convenient to do so before assembling the main frames.

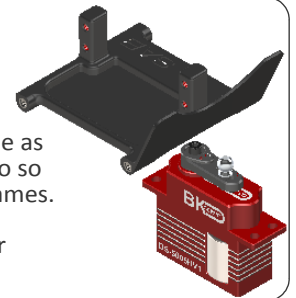

Please refer to page 13 now for more information.

Right Main Frame Assembly

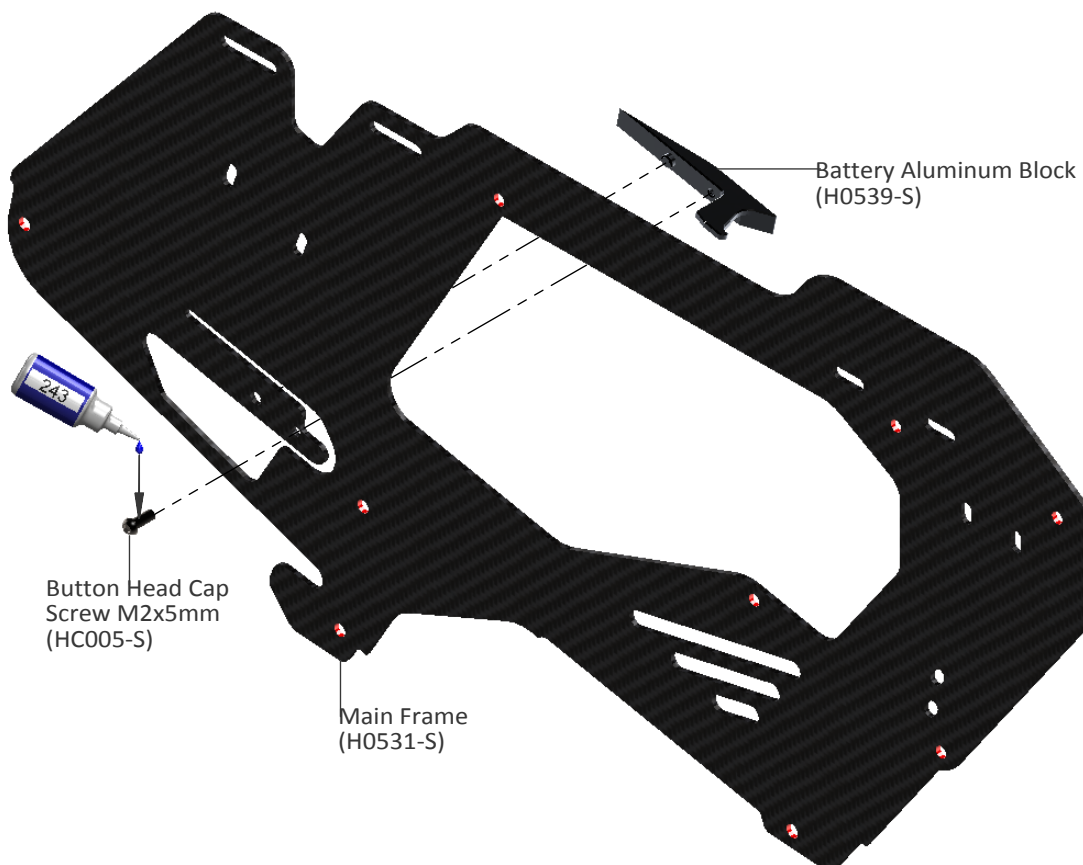

Main Frame Assembly

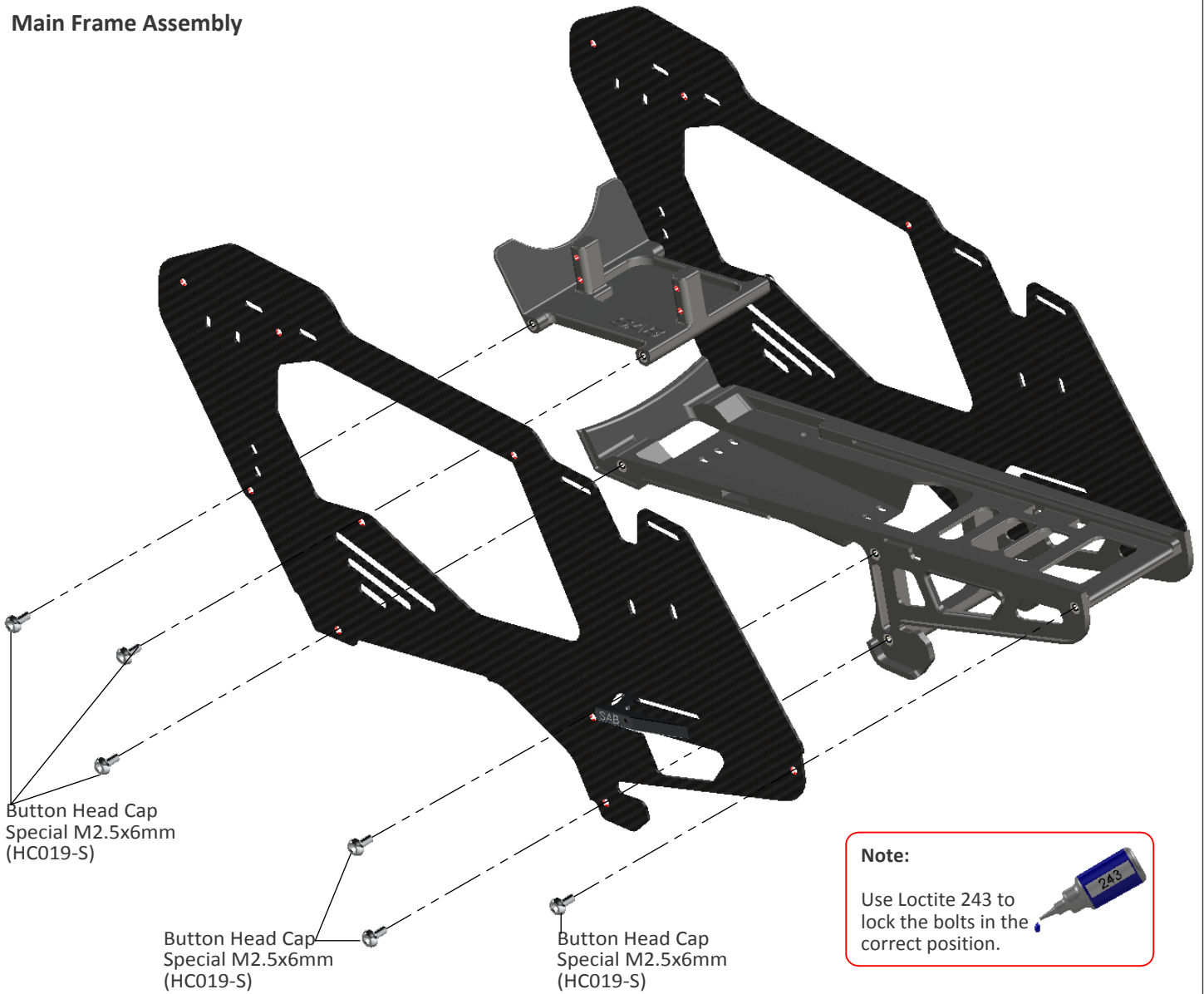

Button Head Cap
Special M2.5x6mm
(HC019-S)

Button Head Cap
Special M2.5x6mm
(HC019-S)

Button Head Cap
Special M2.5x6mm
(HC019-S)

Note:

Use Loctite 243 to
lock the bolts in the
correct position.

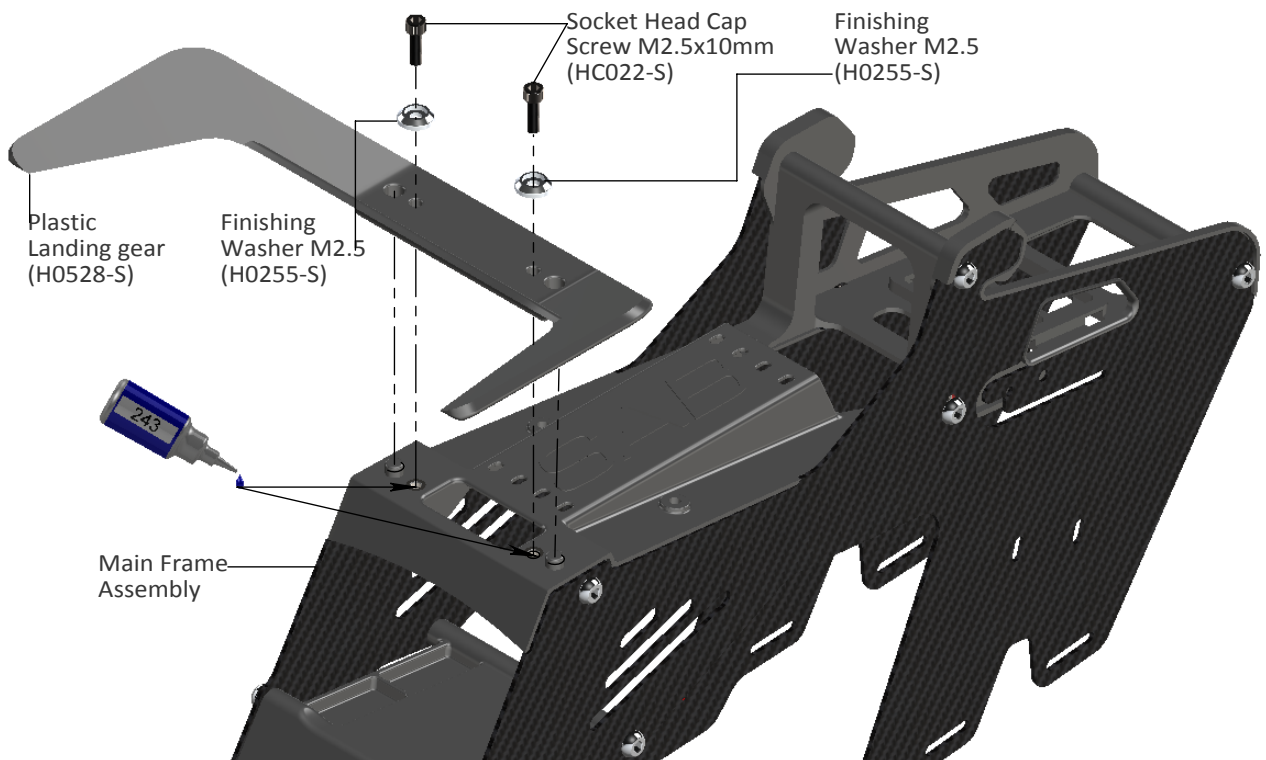

Plastic
Landing gear
(H0528-S)

Finishing
Washer M2.5
(H0255-S)

Socket Head Cap
Screw M2.5x10mm
(HC022-S)

Finishing
Washer M2.5
(H0255-S)

Main Frame
Assembly



Main Shaft Support Assembly

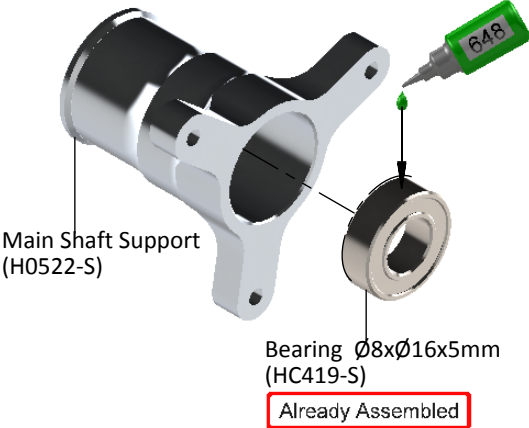

Main Shaft Assembly

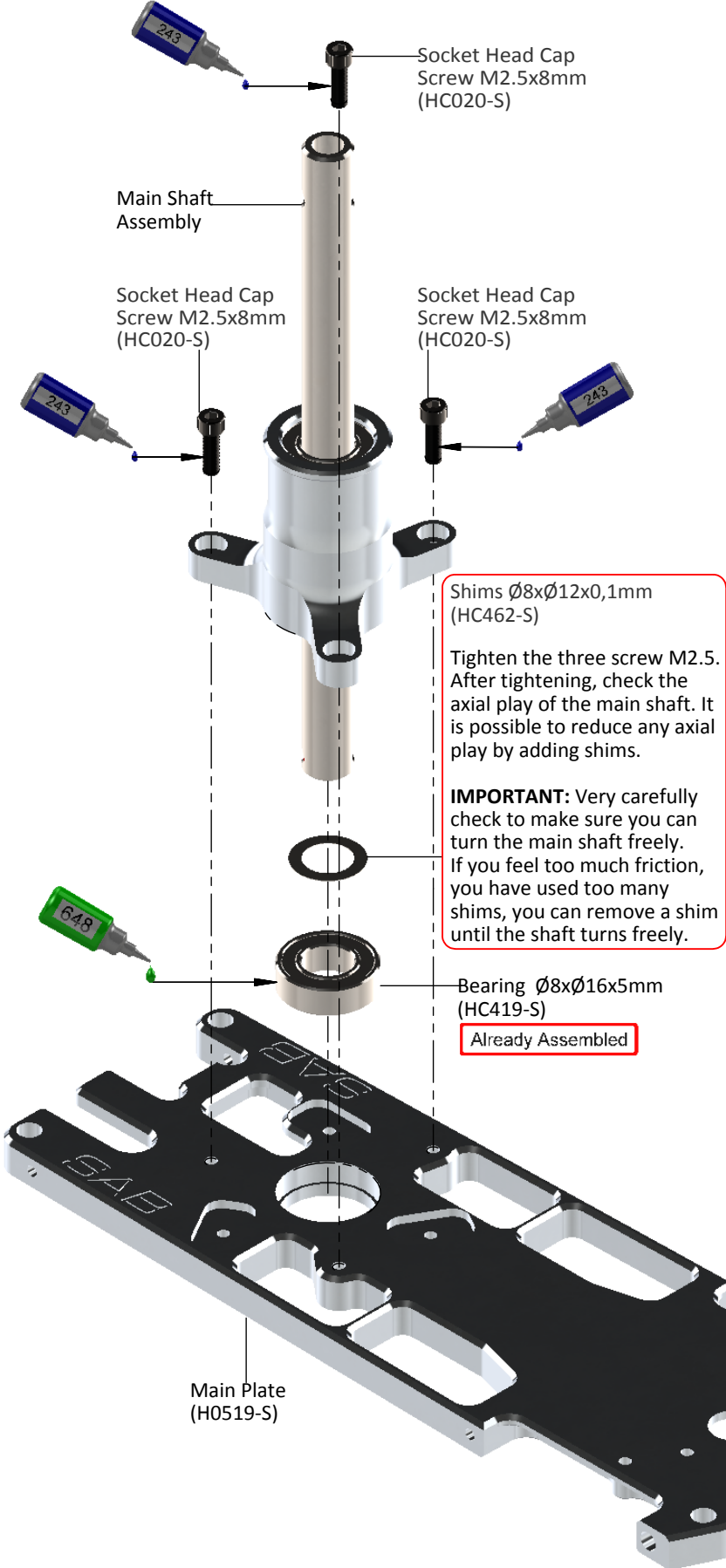
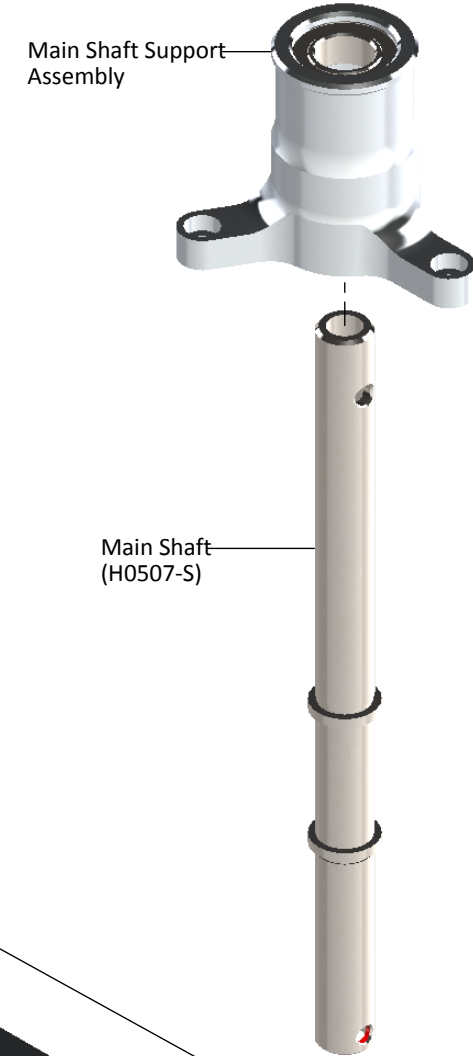

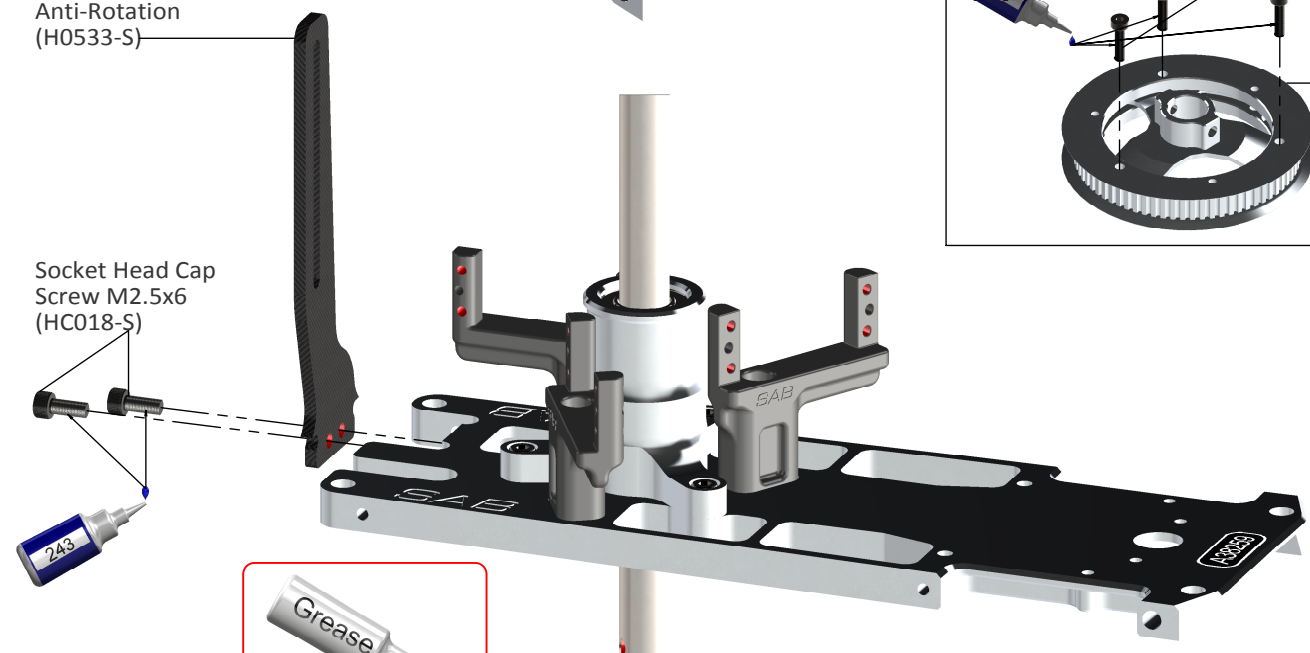
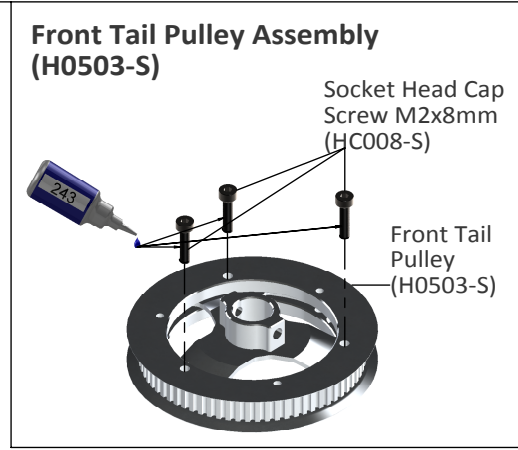
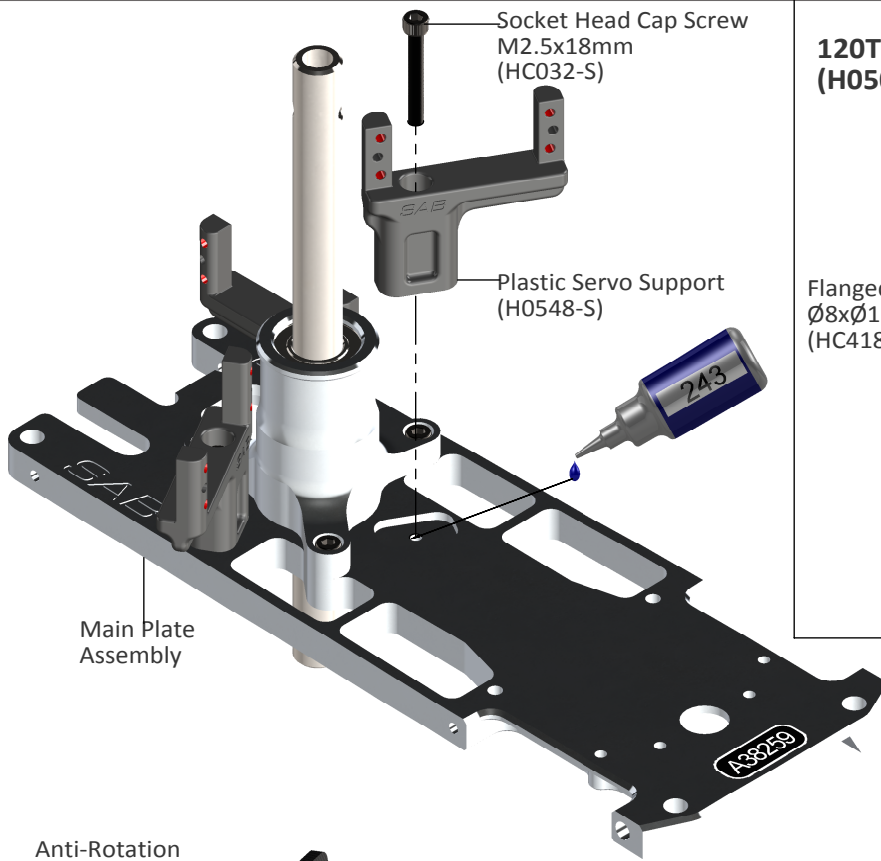

Grease
eg: Microlube GL261

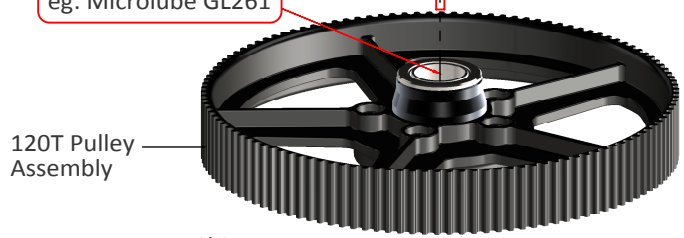

Shims $\varnothing 8 \times \varnothing 14 \times 0,2$ mm (HC228-S)

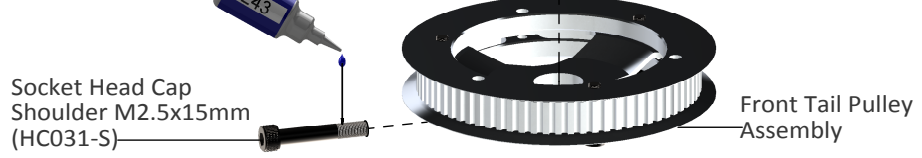

Note:
Add or remove shims to get approximately 0.2-0.4mm play.

Radius Arm Assembly ... x 2

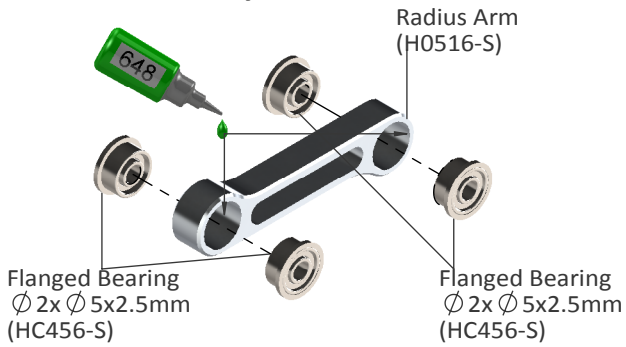

Radius Plastic Arm Assembly ... x 2

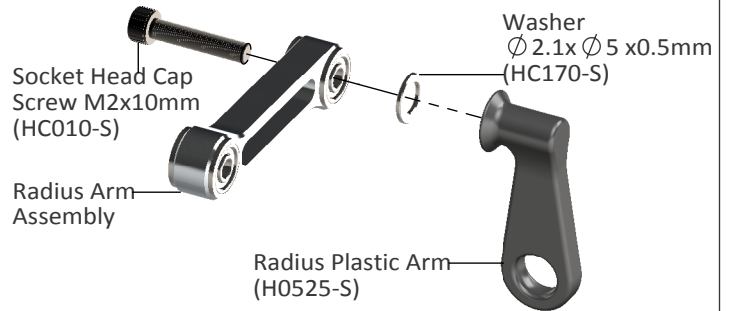

NOTE: Tighten with care, the arm must move freely.

Center Hub Assembly

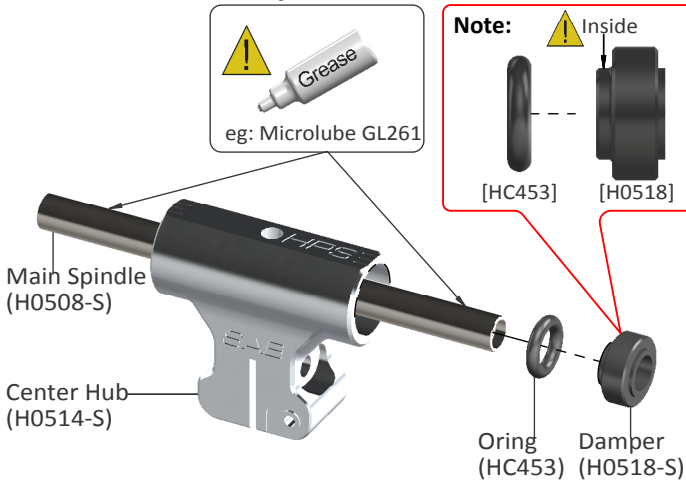

Main Blade Grip Assemblyx2

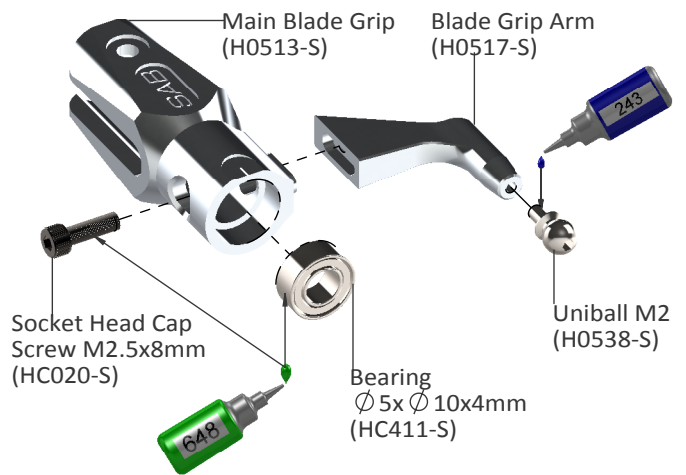

Head HPS Assembly

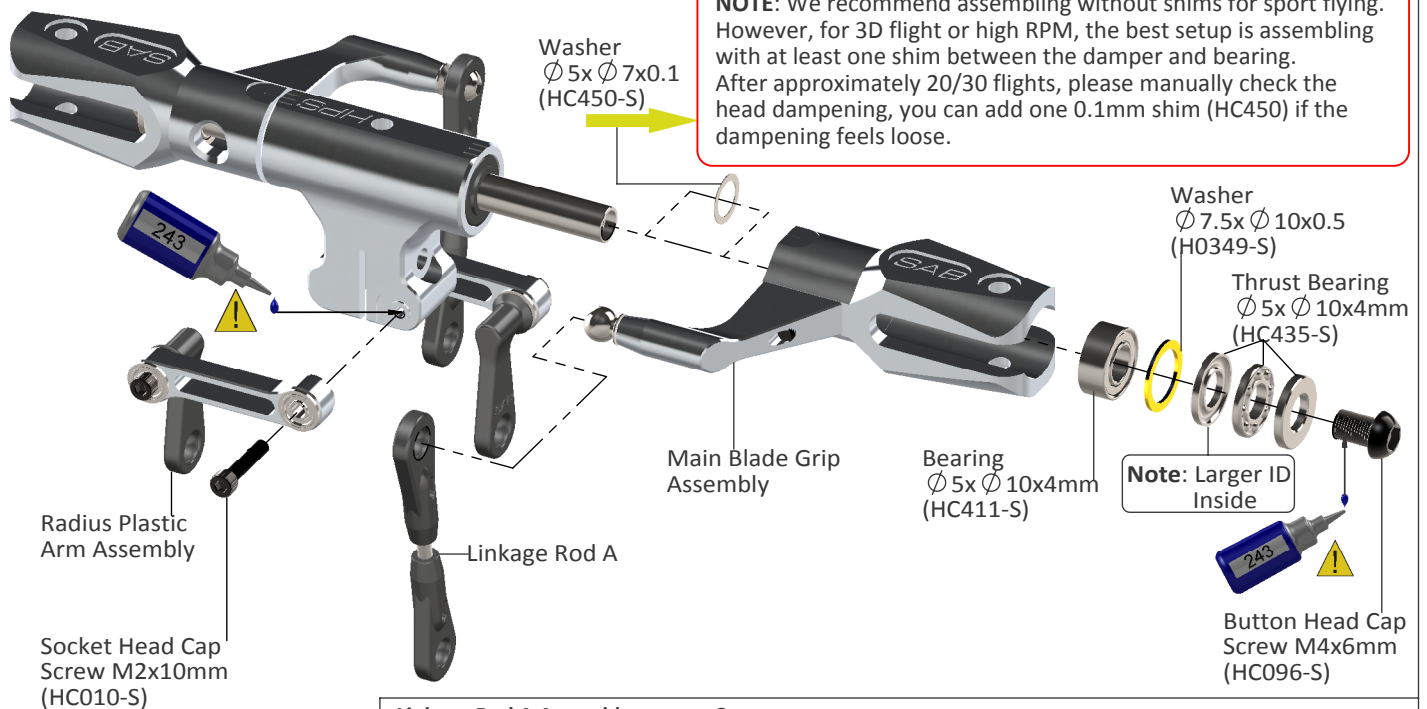

Linkage Rod A Assemblyx2

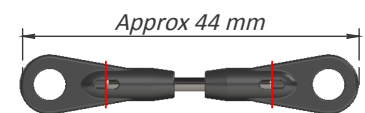
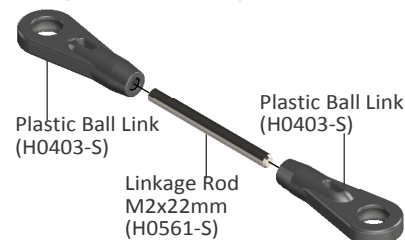

(Initial length for the rods from the swashplate to the Blade Grip.)

Swashplate Assembly

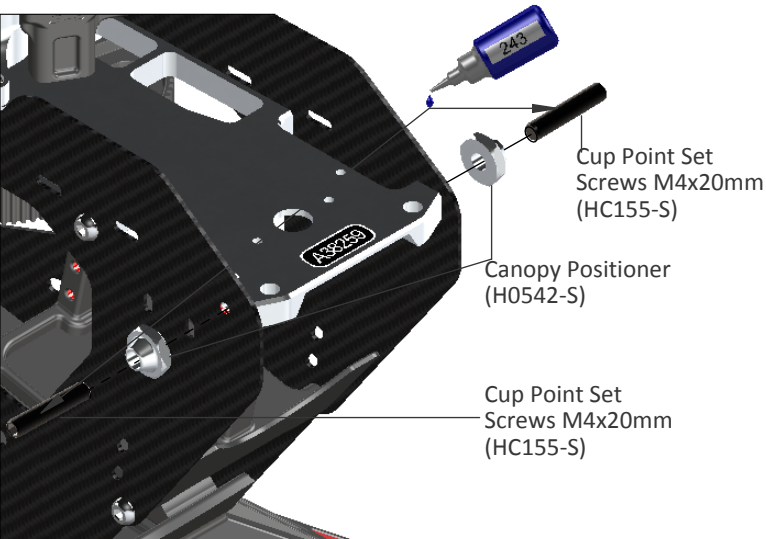
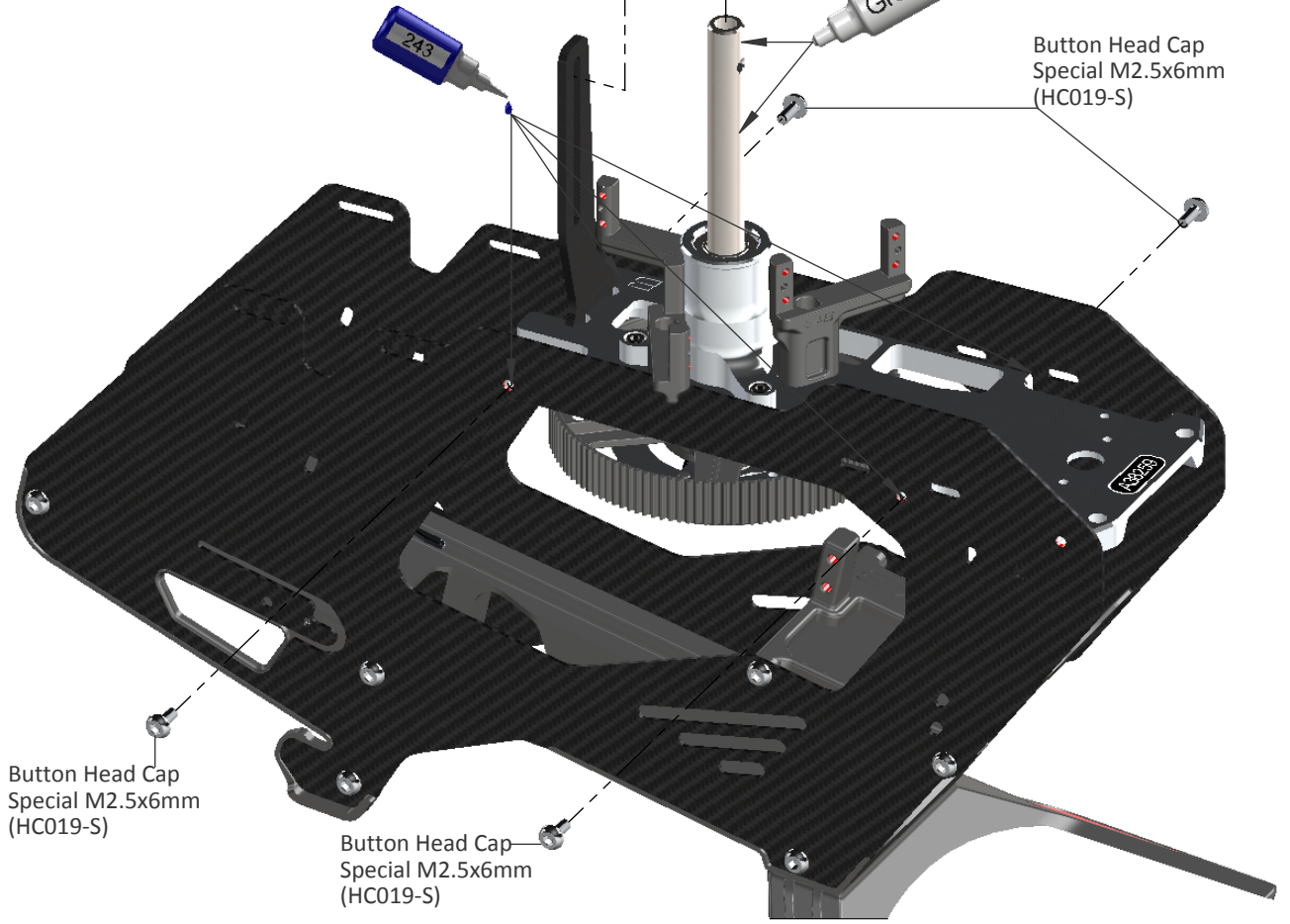
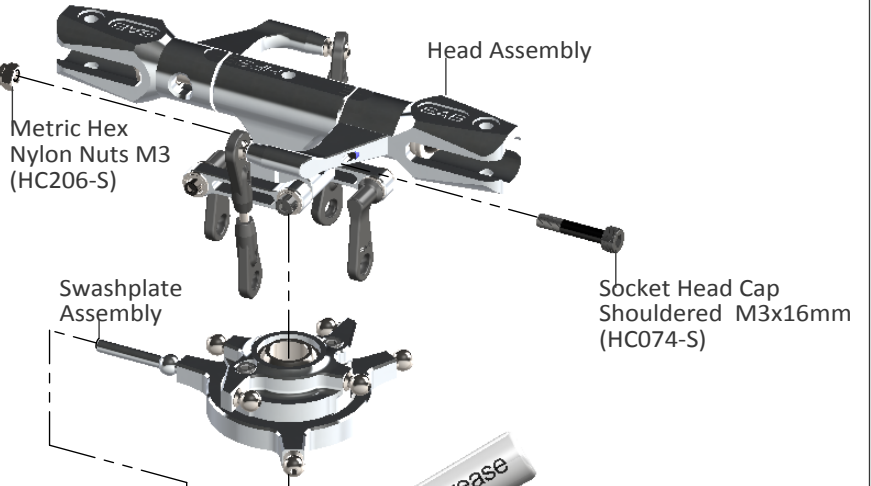
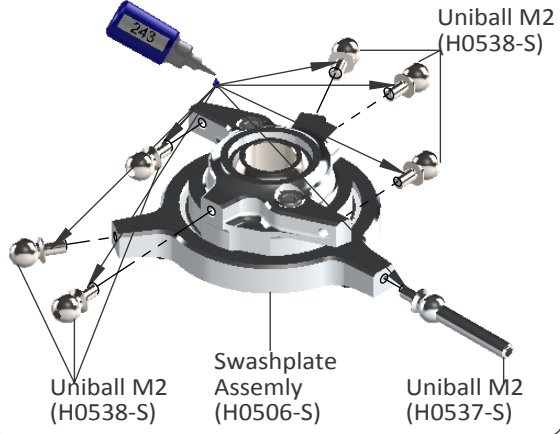

NOTE:
Keep the distance between the end of the canopy retainer H0542 and the frame at approximately 12mm.

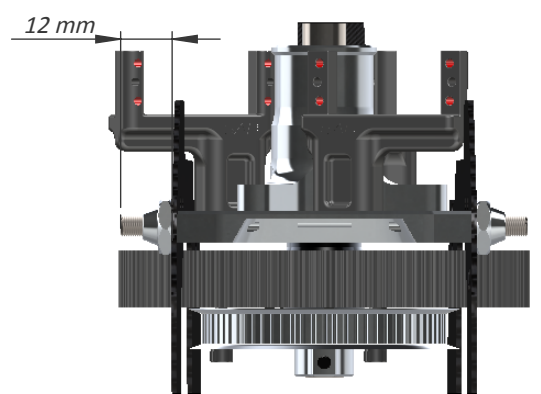

INSTALLATION OF SWASHPLATE SERVOS

The linkage ball must be positioned approximately **13-15 mm** out on the servo arm (**figure 1**), it is recommended to use the SAB servo arm p/n [HA052]. Because of the 120° placement of the servos in the Goblin, the arms are difficult to access. For this reason it is advisable to ensure alignment of the servo arms (and sub trim) before installation of the servos in the model (**figure 2**). Proceed with installation following the instructions below. **Figure 3** shows a completed installation.

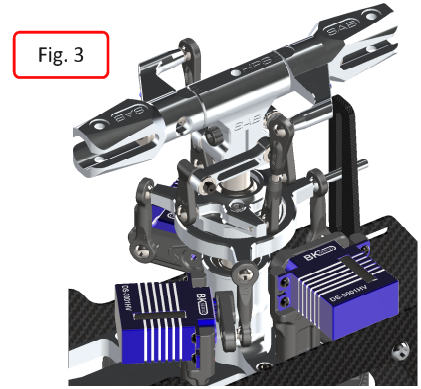
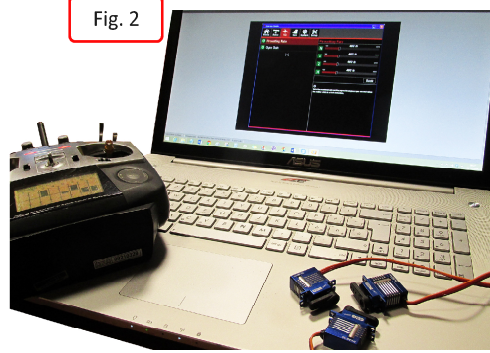

The rods going from the servos to the swash plate must be as vertical as possible. (Red line in Figure 4)
 Not all servos are equal, so for proper alignment you can choose to use the supplied spacer H0566 under the uniball H0538.

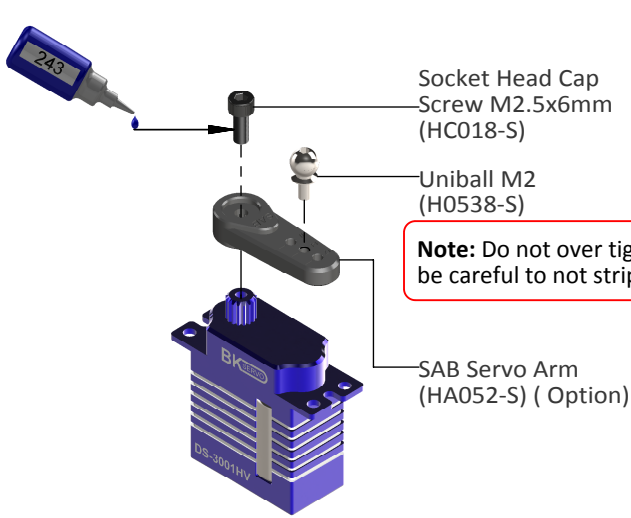

Note: Do not over tighten, be careful to not strip plastic.

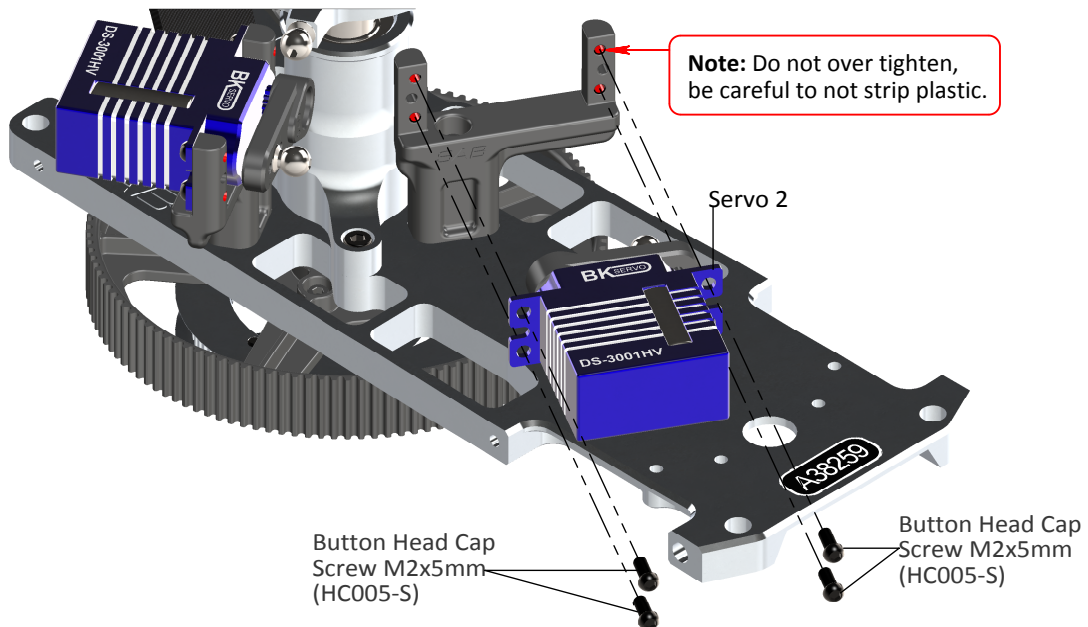
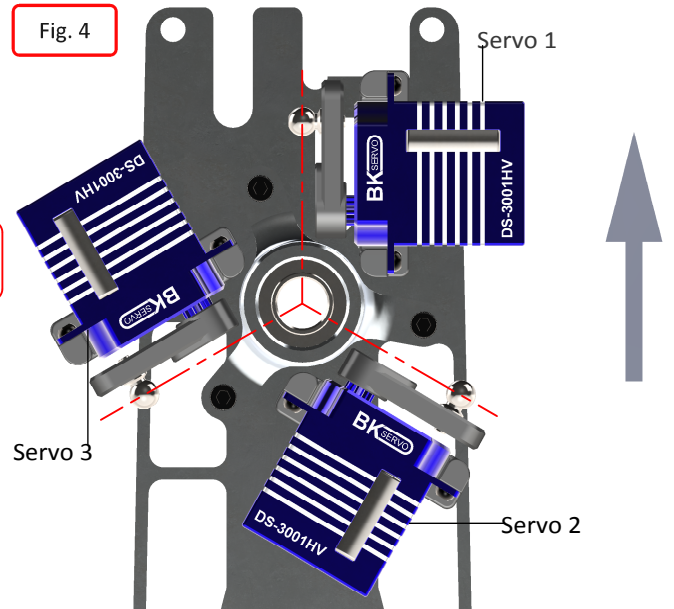

Tip on cable routing

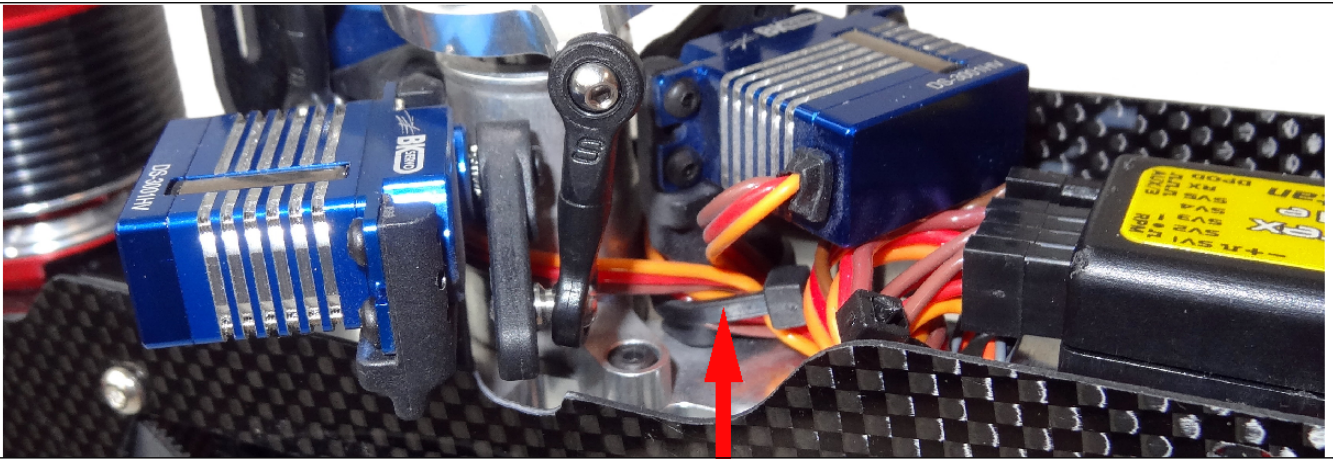

You can use zip-ties to secure the 3 servo cables to the servo support.

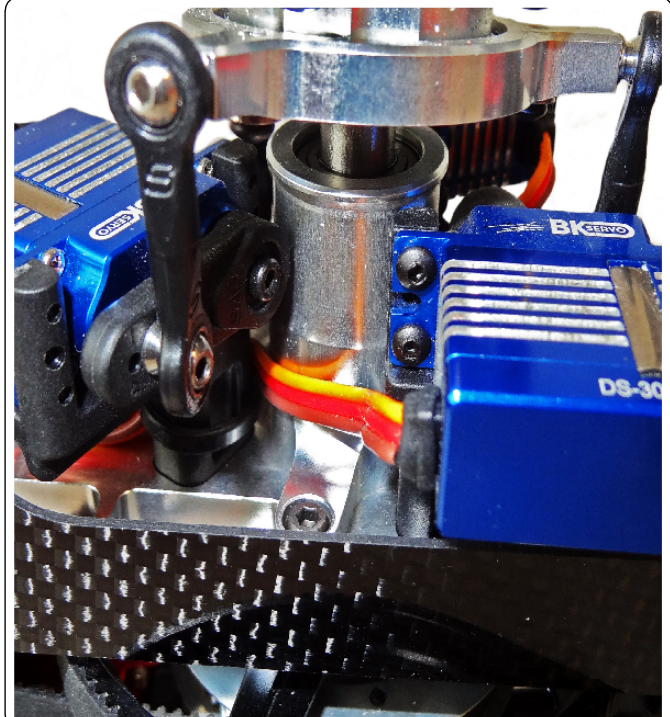

HPS Head Preliminary Setup

Linkage Rod A Assembly ... x2

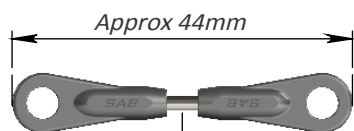

Linkage Rod M2x22mm (H0561-S)

Initial length for the rods from the swashplate to the blade grips.

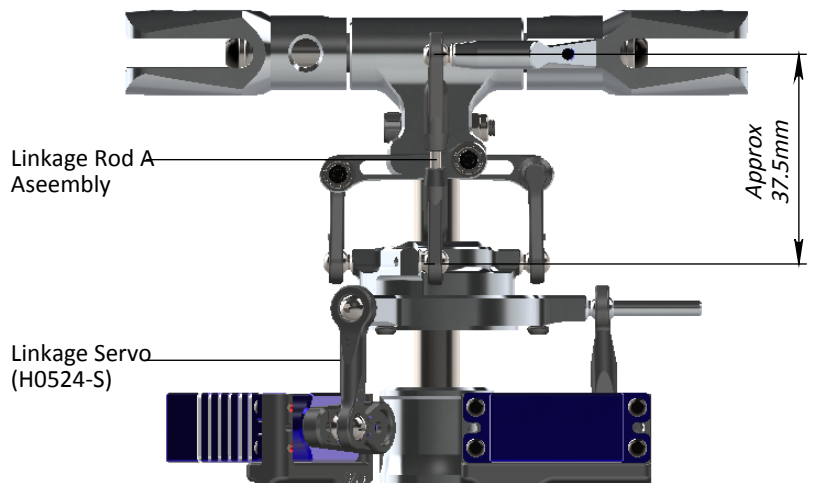



The distance between the servo spline and the ball must be between 13-15 mm
You can use the SAB servo horn [HA053].

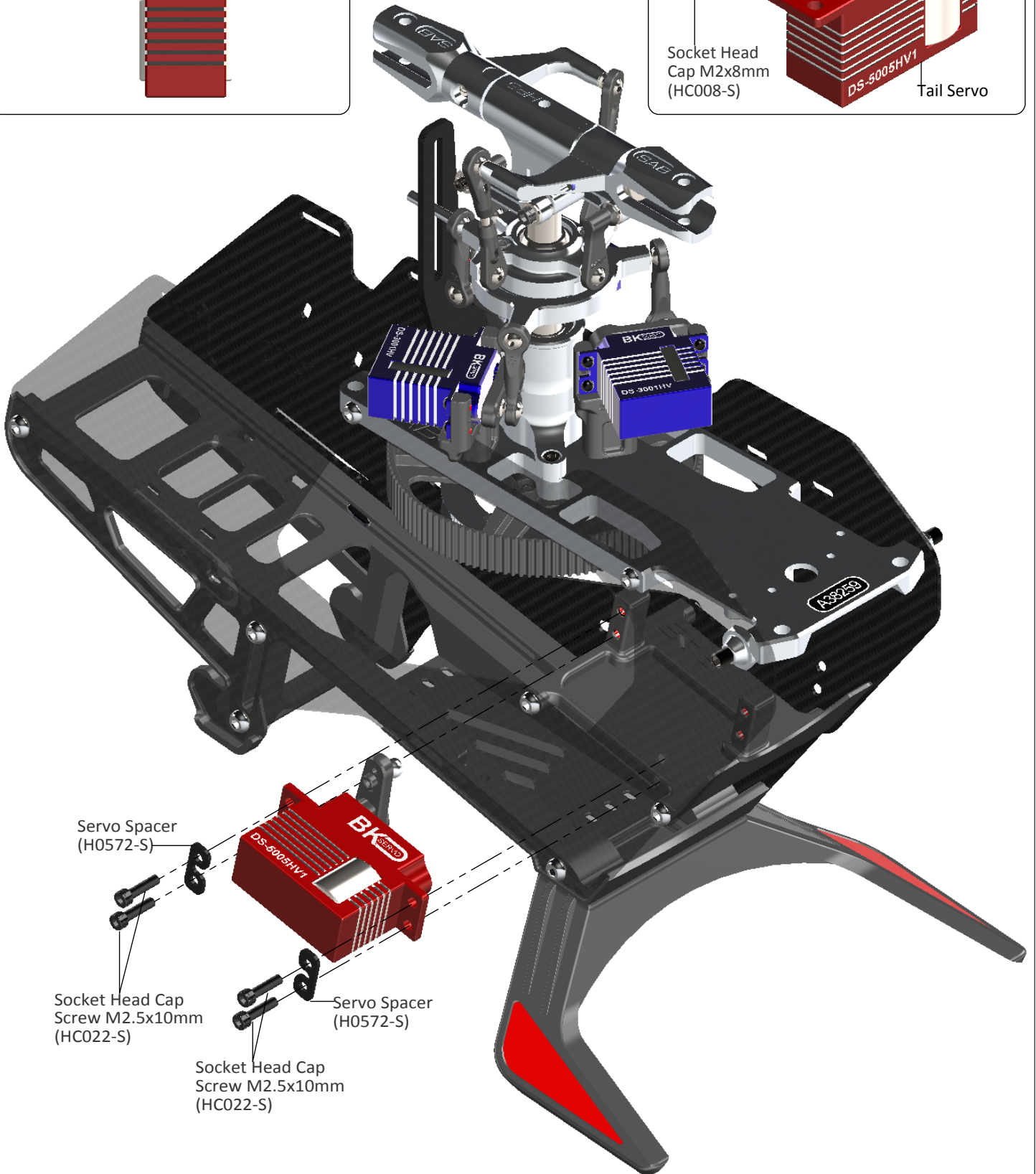
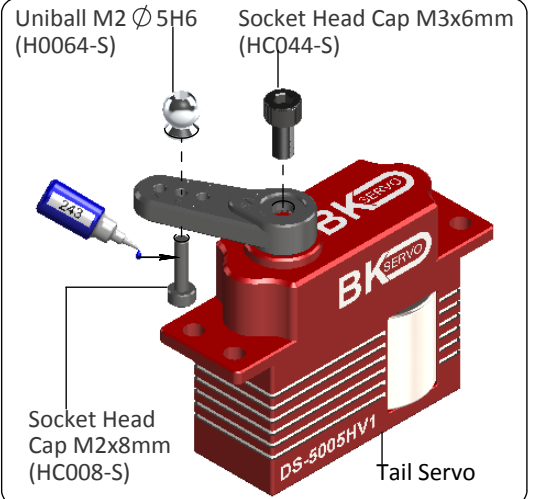

TRANSMISSION SETUP

It is important to choose the right reduction ratio to maximize efficiency based on your required flight performance. It is possible to optimize any motor and battery combination. It is recommended to use wiring and connectors appropriate for the currents generated in a helicopter of this class.

If you are using a head speed calculator which requires a main gear and pinion tooth count, use **120** teeth for the main gear and the tooth count of your pulley as the pinion count.

Below is a list of available reduction ratios:

H0501-19-S - 19T Pinion = ratio 6.3:1	H0501-22-S - 22T Pinion = ratio 5.5:1
H0501-20-S - 20T Pinion = ratio 6:1	H0501-23-S - 23T Pinion = ratio 5.2:1
H0501-21-S - 21T Pinion = ratio 5.7:1	H0501-24-S - 24T Pinion = ratio 5:1

The Goblin 380 accepts a wide selection of batteries with different capacities. The suggested number of cells is 6.

All batteries from 1500 to 2600 mAh offer good performance.

We recommend the use of an 1800 mAh battery for the perfect compromise between weight and performance (3D flight). Larger capacity batteries (2200-2600) increase flight times at the expense of weight and reduced agility (Sport flight).

Some example configurations:

CONFIGURATION

Motor	ESC	Motor Pulley	RPM Max	Pitch
Quantum 2820-880	CC Lite 75	23T	3250	±12.5
	Koby 70 - YGE 60	21T	3250	
Scorpion HK 3014-900	CC Lite 75	23T	3300	±12.5
	Koby 70 - YGE 60	21T	3300	
X-NOVA 2820-890	CC Lite 75	24T	3400	±12.5
	Koby 70 - YGE 60	22T	3400	
Scorpion HK 3020-1000	CC Lite 75	22T-23T	3400-3550	±12.5
	Koby 70 - YGE 60	19T-20T	3400-3550	
	CC Lite 100	22T-23T	3550-3700	
	Koby 90 - YGE 90	20T-21T	3550-3700	
KDE 500XF 925-G3	CC Lite 75	23T-24T	3400-3550	±12.5
	Koby 70 - YGE 60	21T-22T	3400-3550	
Kontronik Pyro 380-9	CC Lite 100	24T-25T	3550-3700	
X-NOVA 3215-930	Koby 90 - YGE 90	22T-23T	3550-3700	



Note: Although the Goblin can handle even higher RPMs, for safety reasons we suggest to not exceed 3600 RPM.



Motor Pulley 21T
(H0501-21-S)

(see page 14 for optional pulleys)

Cone Point Set
Screws M3x6mm
(HC144-S)

Flat Head Socket
Cap M3x5mm
(HC132-S)

Motor Support
(H0520-S)

Motor

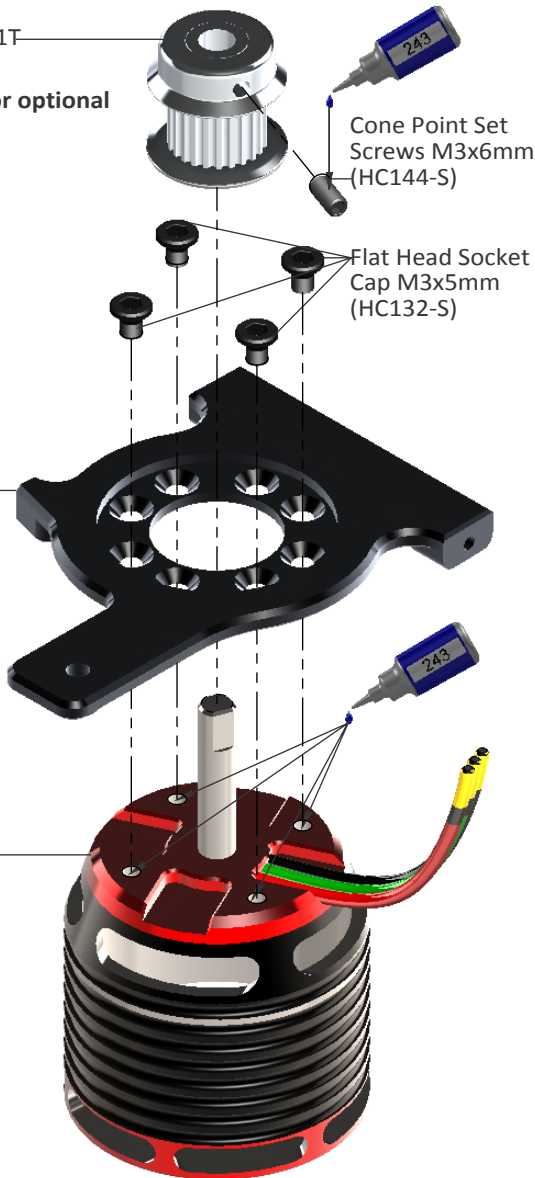

NOTE:

Correct position for the motor wires.

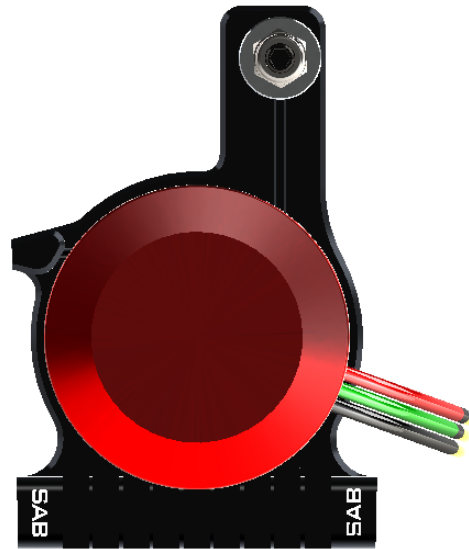

Socket Head Cap
Screws M2.5x8mm
(HC020-S)

Finishing Washer M2.5
(H0255-S)

Socket Head Cap
Screws M2.5x8mm
(HC020-S)

Metrix Hex
Nylon Nut M4
(HC212-S)

Washer
Ø 4.3x Ø 11x1mm
(HC184-S)

Cone Point Set
Screws M4x12mm
(HC156-S)

Finishing Washer M2.5
(H0255-S)

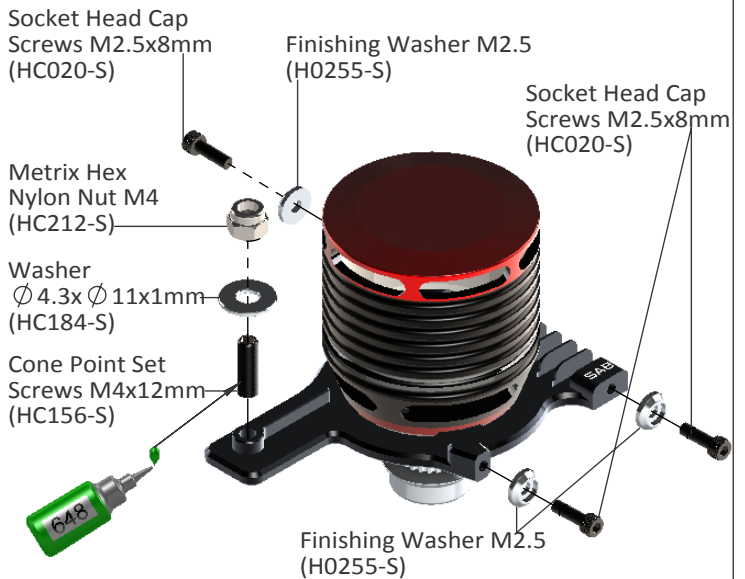

NOTE:

To maximize space for the batteries, it is advisable to shorten the motor shaft. Follow the dimensions given in this drawing. For the cut, you can use an electric tool like a "Dremel" with a cutoff disc.

Additionally, ensure the motor shaft has an appropriate 'flat' for one of the set screws.

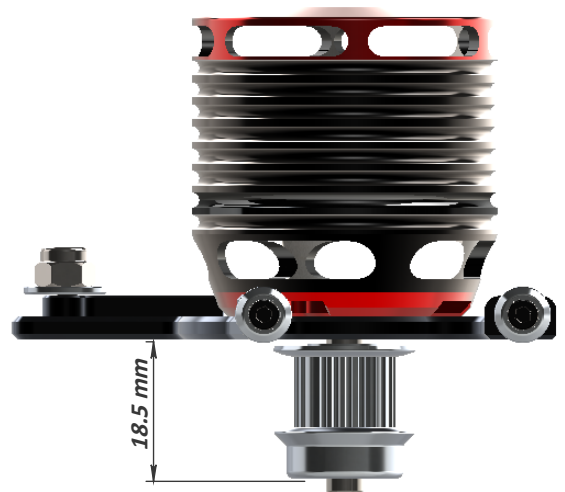
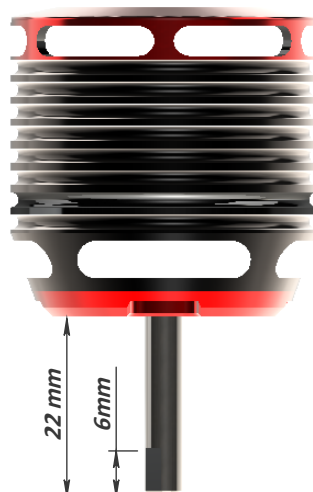

MOTOR BELT TENSION

- *Assemble the motor and pulley to its mounting plate.
- *Install the motor assembly in the helicopter.
- *It is easy to install the belt with the motor assembly pushed back towards the helicopter as far as it can go.
First put the belt on the motor pulley.
- *Then put the belt around the big pulley.
- *Rotate the motor several times by hand.
- *Pull and hold the motor slightly.
- *Tighten the M4 nut first (It is suggested to use tool nut driver).
- *The belt must be very tight.
- *Tighten the rest of the bolts.

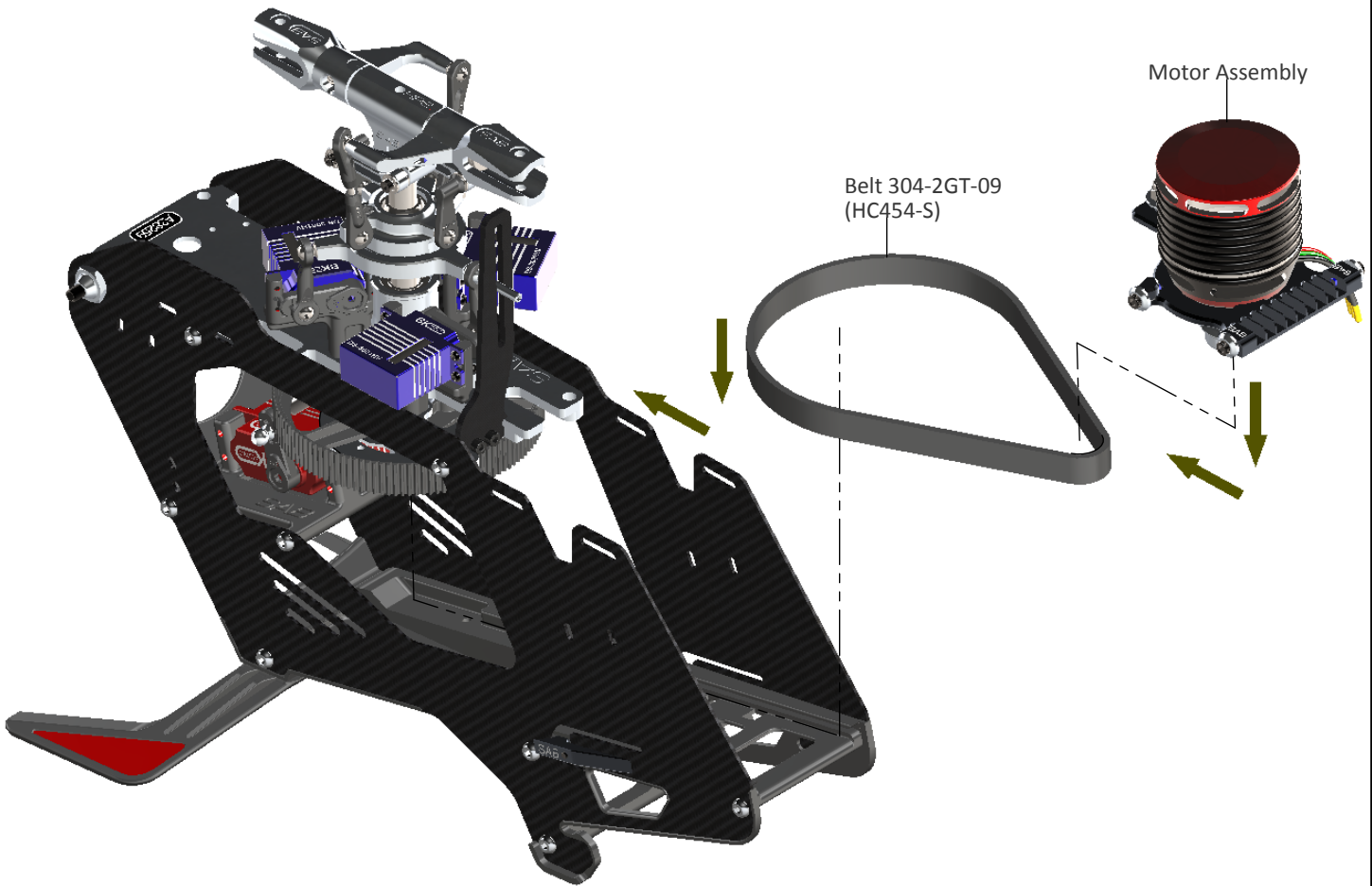

Note:

Check for vertical alignment of the motor pulley. To do this, simply turn the motor several times by hand and check to you see if the belt is aligned properly with the big pulley (one way bearing pulley).

If the belt is riding too high, simply loosen up the motor pulley and drop it just a little bit, if it is riding too low, loosen up the motor pulley and raise it a bit.

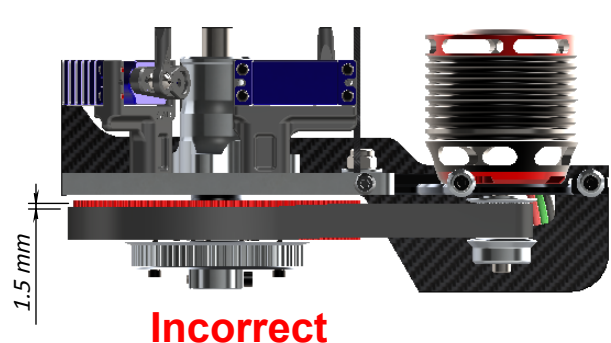
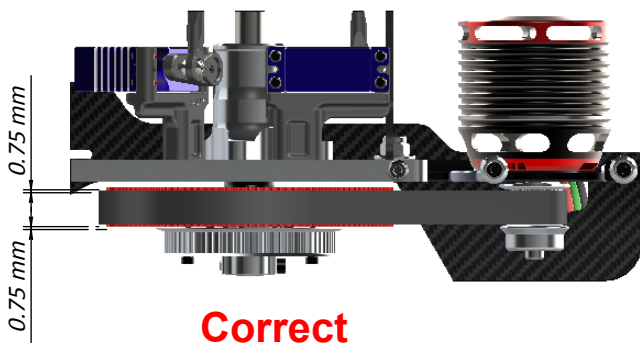

DE-BURR THE SIDE FRAMES

We recommend de-burring the edges of the carbon parts in areas where electrical wires run. (See Page 4).



ESC INSTALLATION

The speed controller (ESC) is installed in the front of the helicopter. **Figure 1** and **Figure 2** show the mounting area.



Fig. 1

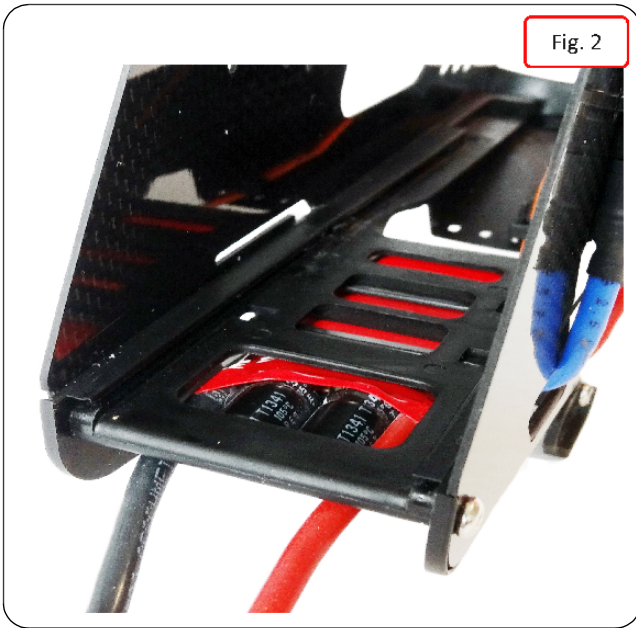

Fig. 2

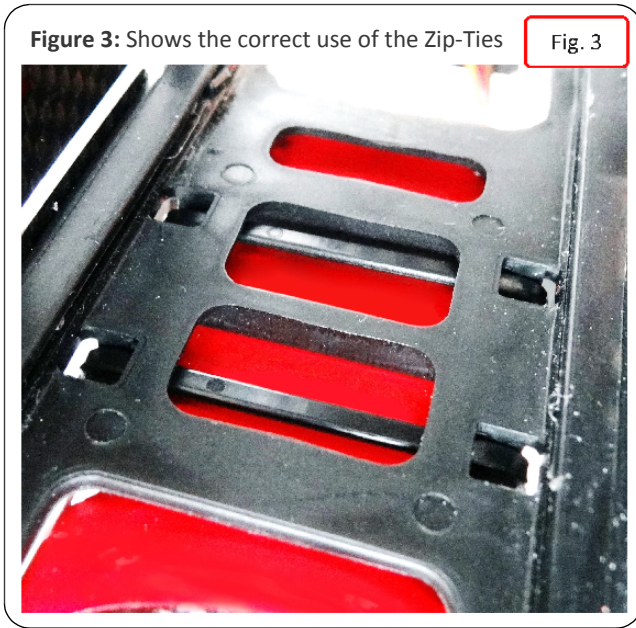

Figure 3: Shows the correct use of the Zip-Ties

Fig. 3

Figure 4: Shows the suggested length of the battery wire. This length is also compatible with the quick battery connector upgrade.

Figure 5: Shows the wire that connects the ESC to the receiver or flybarless control system.

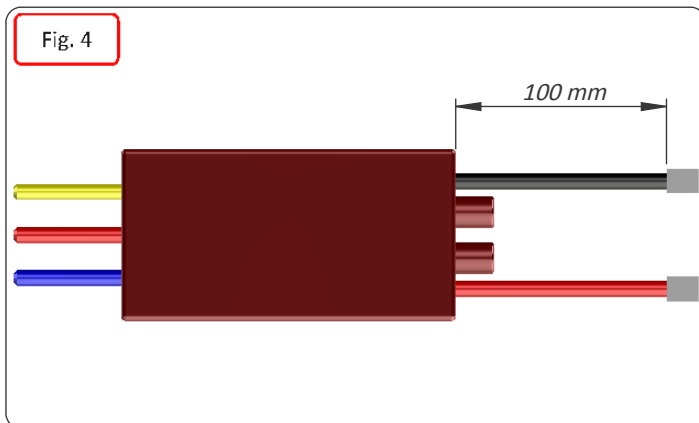

Fig. 4

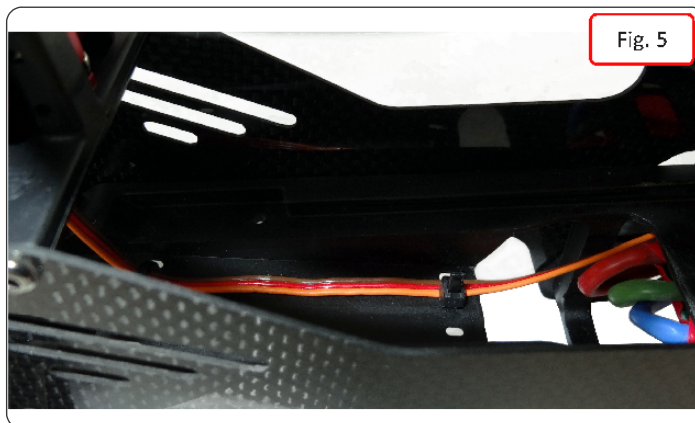

Fig. 5

FLYBARLESS CONTROL UNIT AND RX INSTALLATION

We suggest the use of a “single unit” FBL system (all in one type unit). This allows for easier wire routing considering the small size of this helicopter.

Position 1 can be used to install the FBL unit.

Position 2 and 3 can be used to install a small RX unit, like a Spektrum satellite.

Position 4 and 5 can be used to install RX unit.

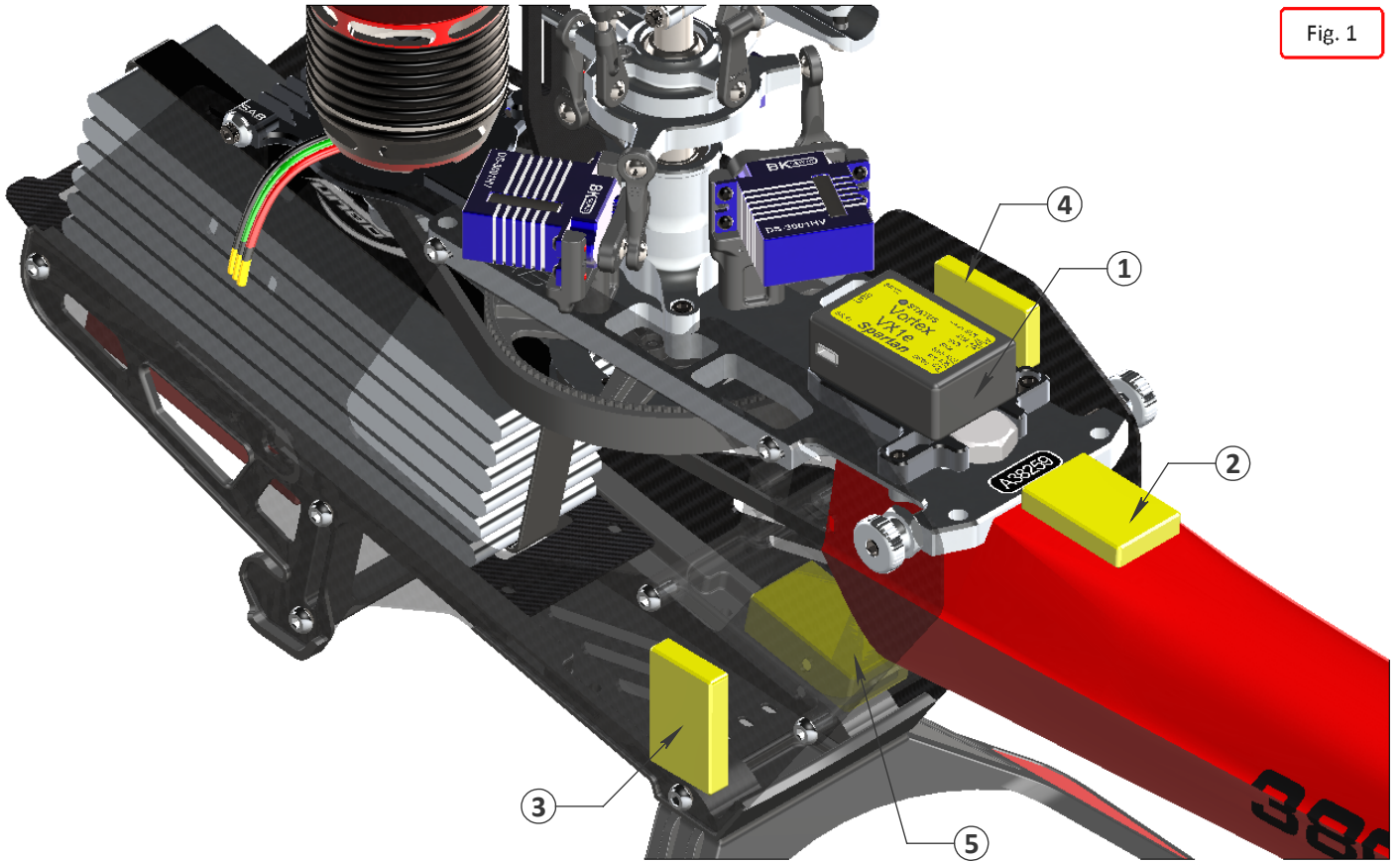

Fig. 1

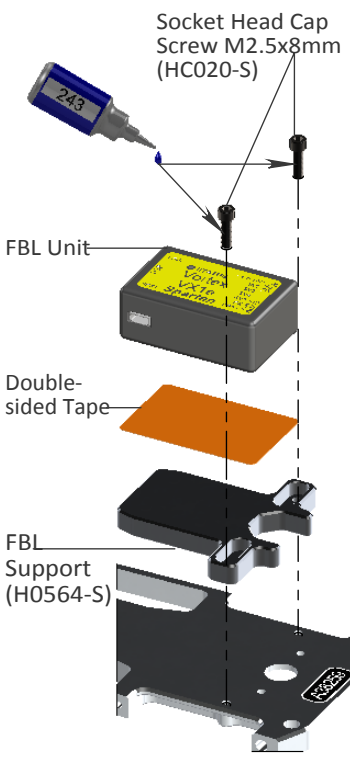

Fig. 2 shows the unit mounted on the support H0564.
Fig. 3 shows the unit directly mounted on the main aluminum plate.

Use your judgment to decide whether you need to install your FBL unit as shown in Fig 2 or Fig 3. This will depend on the size of the FBL unit itself and the arrangement of the wires.

With larger units, the nylon nut can make it difficult to connect the wires to the unit, in this case it is recommended to use the aluminum support H0564.

With smaller units, the unit can be installed directly onto the main plate. This facilitates boom removal in the future if necessary.

We recommend using some type of adhesive to prevent the servo wires and connections from coming unplugged from the receiver or FBL unit. You can use hot glue for this purpose.

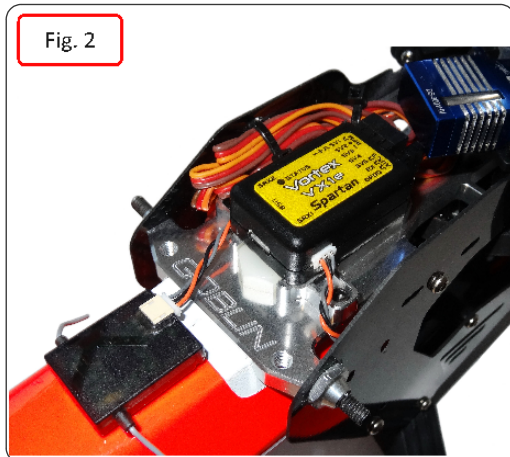

Fig. 2

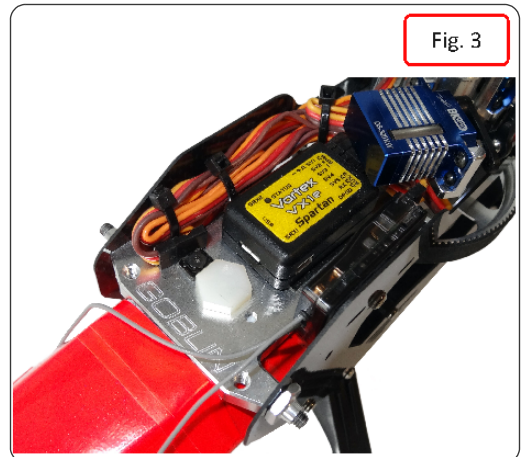
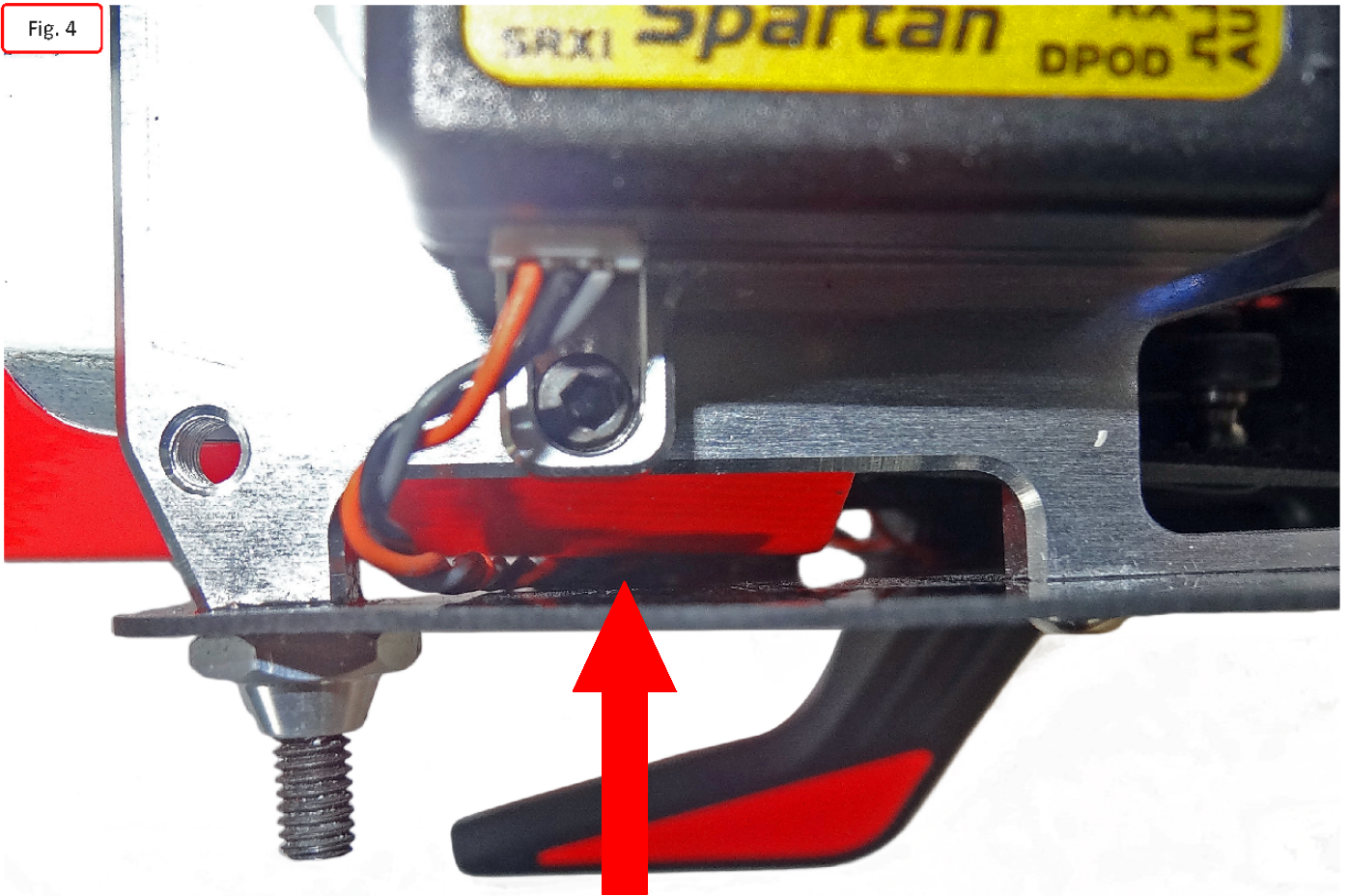

Fig. 3

Fig. 4



The area between the boom and the frame can be used to route the wire(s) (Fig 4 and 5).

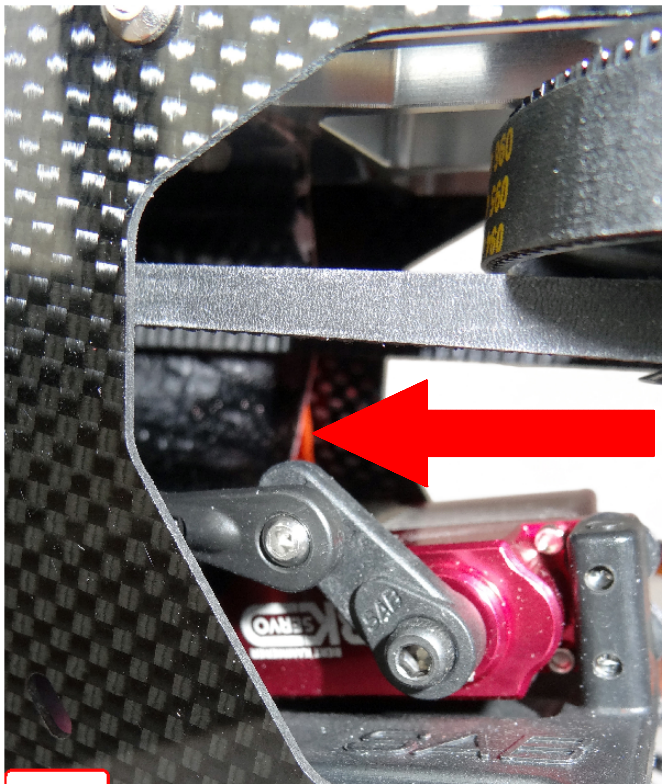

Fig. 5

You can secure the wire(s) to the frame with zip-ties (Fig6).

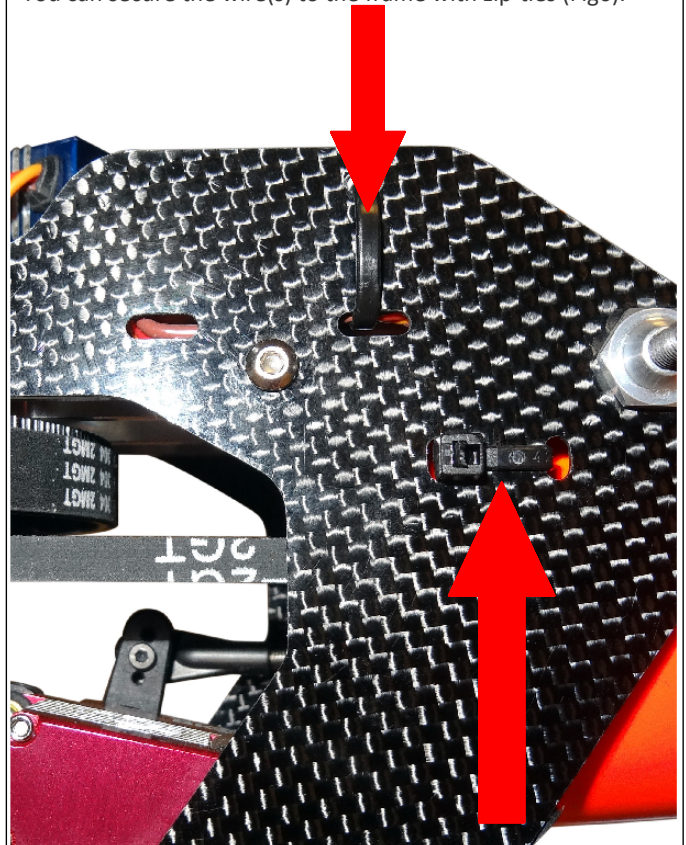
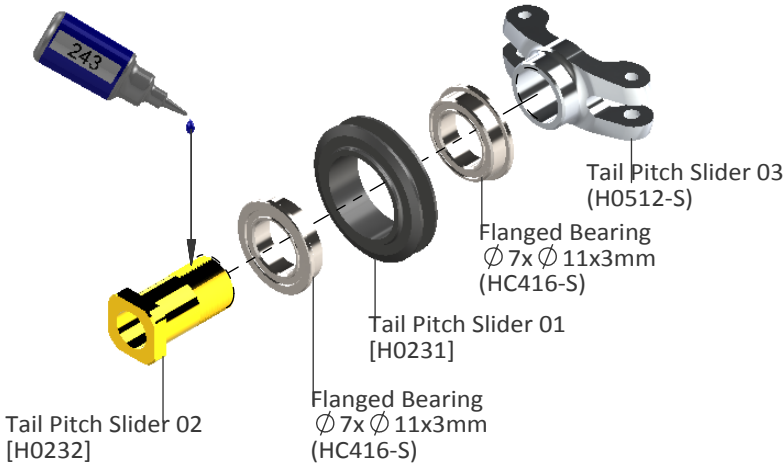

Fig. 6



Tail Pitch Slider Assembly

Already Assembled



Tail Rotor Hub Assembly

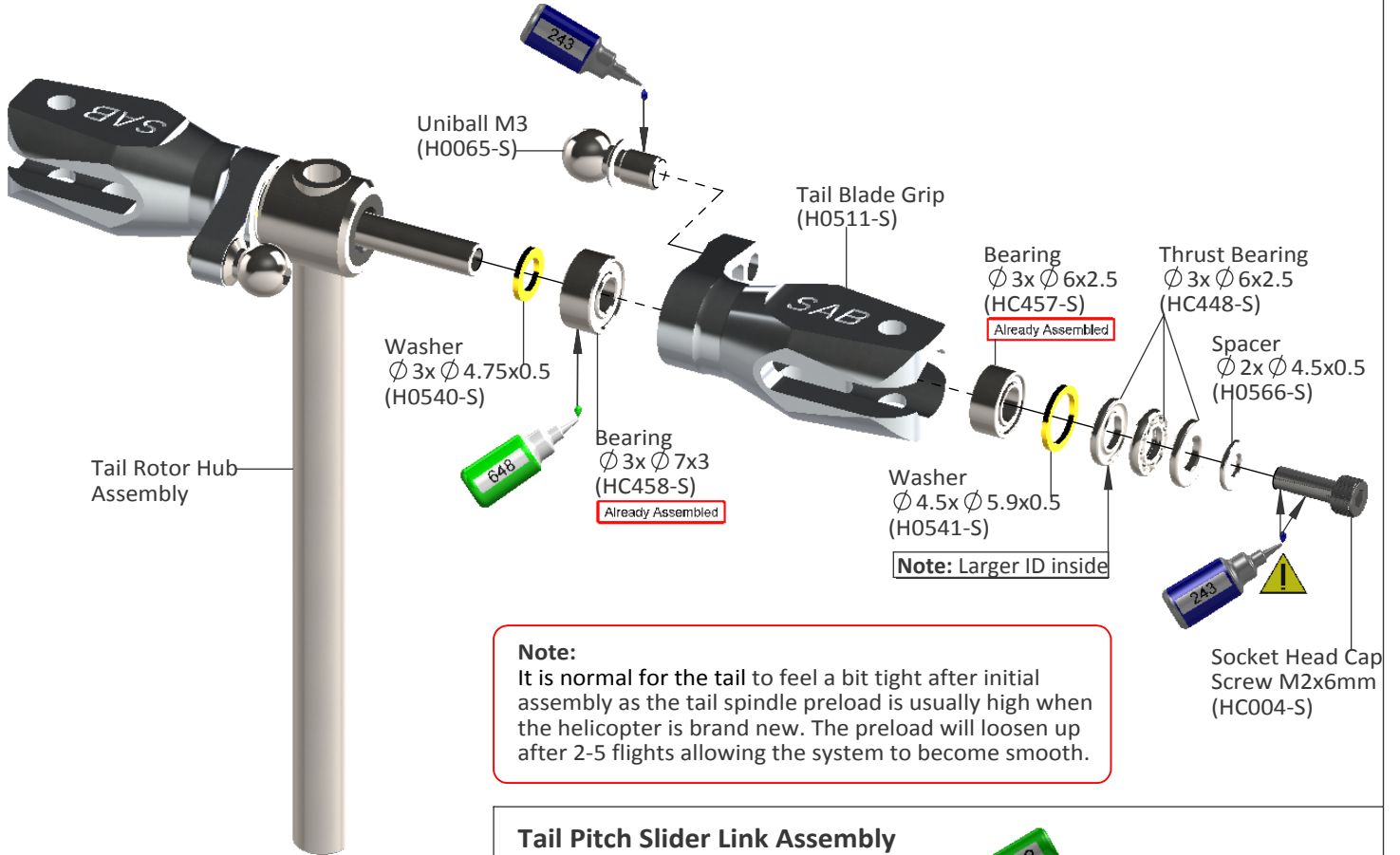
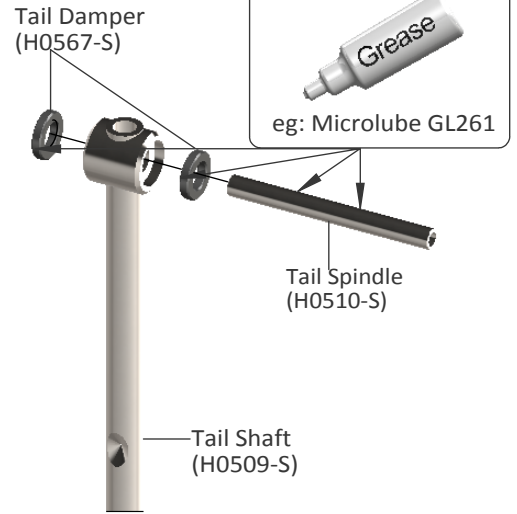

Note:
It is normal for the tail to feel a bit tight after initial assembly as the tail spindle preload is usually high when the helicopter is brand new. The preload will loosen up after 2-5 flights allowing the system to become smooth.



Tail Pitch Slider Link Assembly

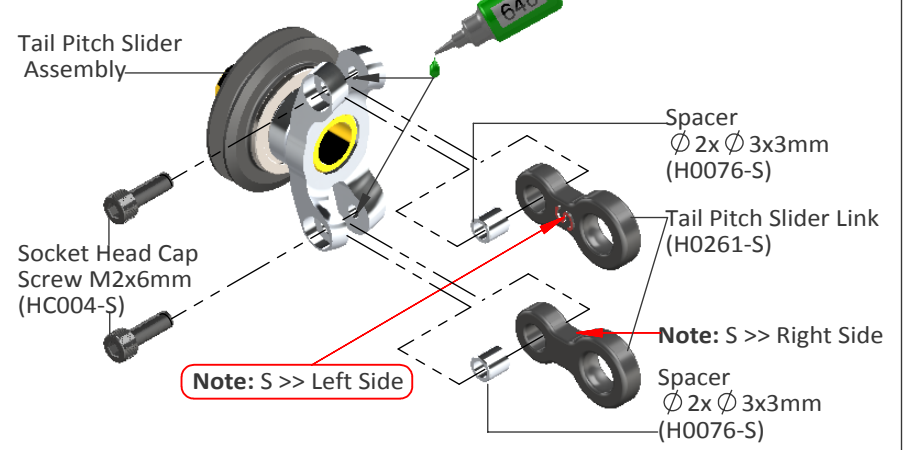

Tail Side Plate Assembly

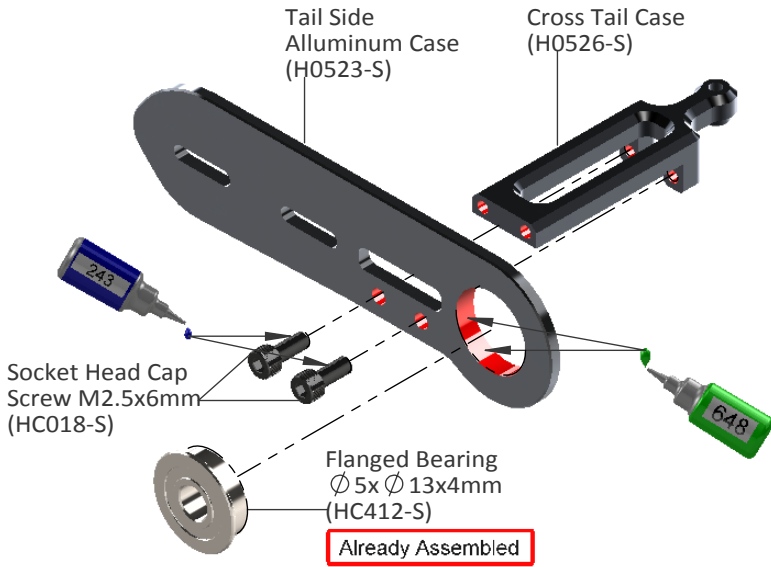

Bell Crank Lever Assembly

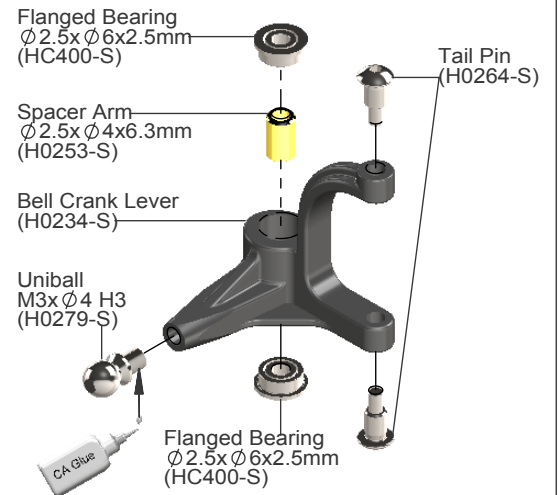

Tail System Assembly

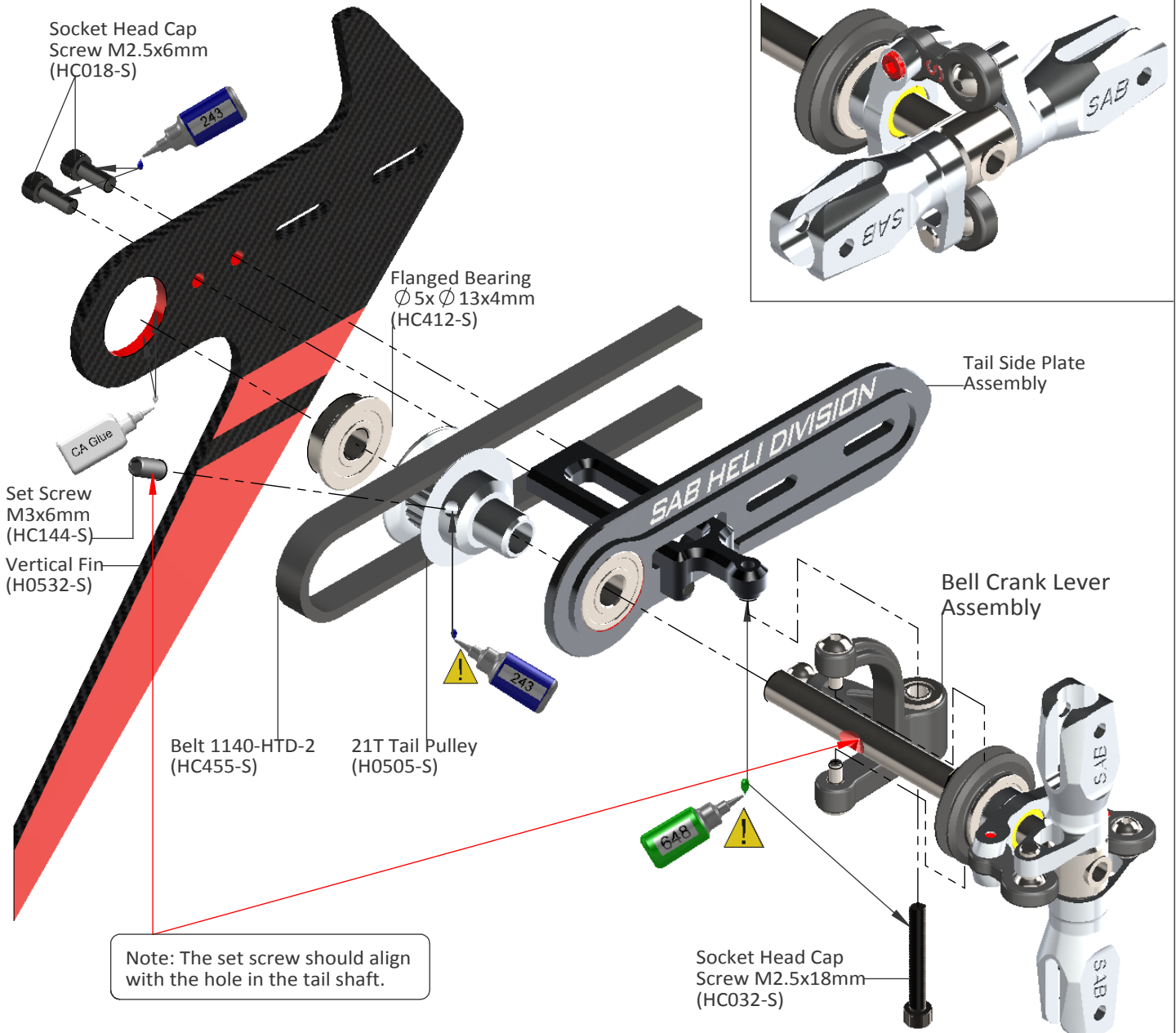

Note: We suggest to clean the sticking surface with sand paper.

Locking Element Tail Assembly x 2

Locking Element Tail
(H0535-S)

Already Assembled

Metric Hex
Nylon Nut M2.5
(HC200-S)



Tail Boom Assembly

Red Tail Boom
(H0547-S)

Locking Element
Tail Assembly
(H0535-S)

Double
Sided Tape
(HA033-S)

Double
Sided Tape
(HA033-S)

M8 Carbon Block Assembly



Metrix Nylon
Nut M8
(HC224-S)

M8 Carbon Block
(H0534-S)

M8 Carbon Block
Assembly

Double Sided Tape
(HA034-S)

Red Tail Boom
(H0547-S)
Yellow Tail Boom
(H0546-S)

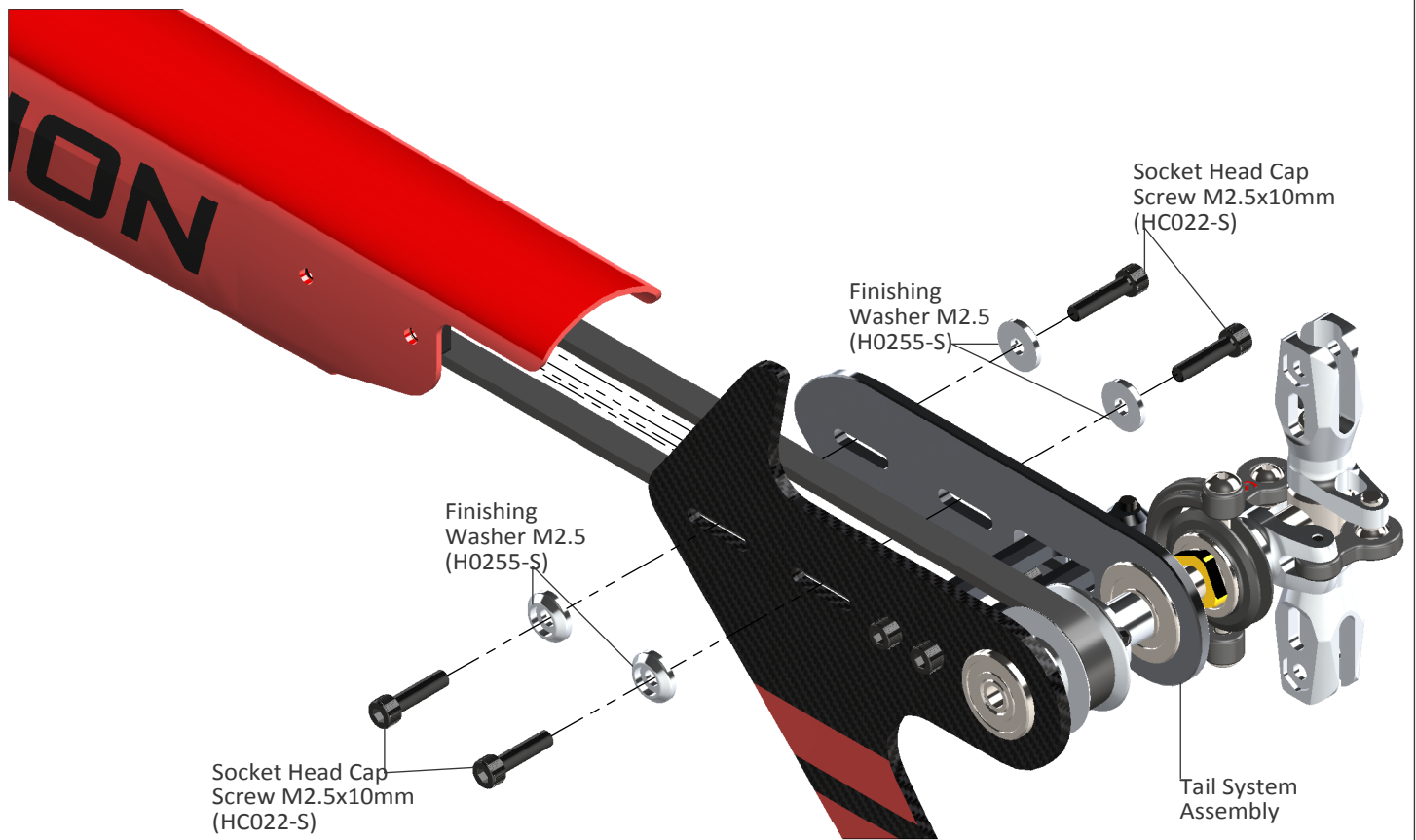

Note: Please allow plenty of time for the glue to cure before inserting plastic ball link onto the threaded rod.

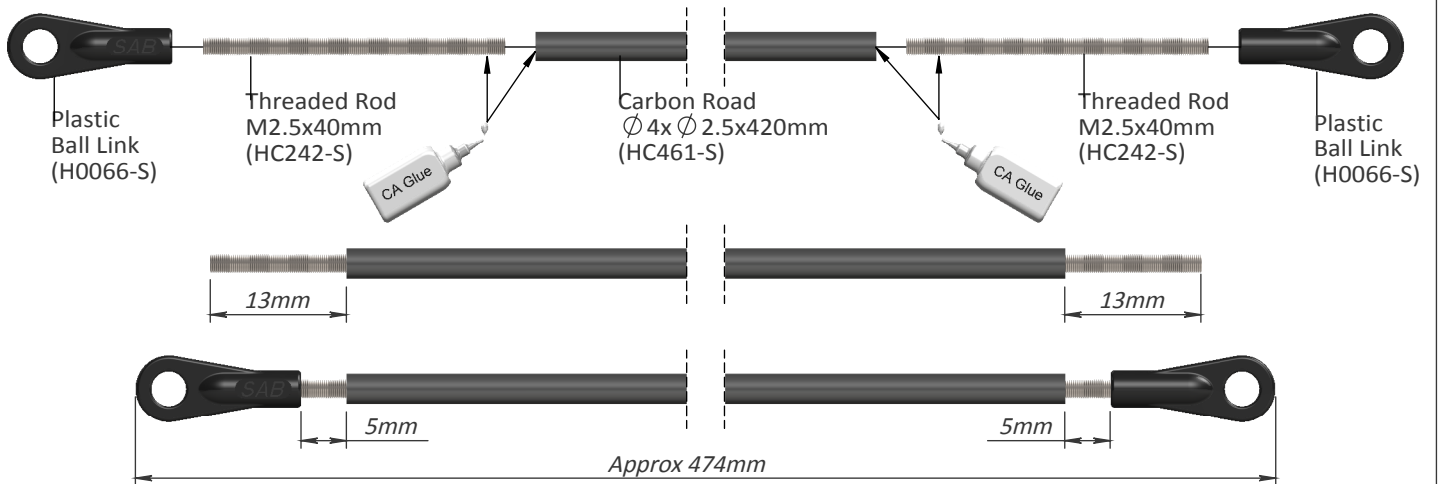

BOOM ASSEMBLY

- * Insert the boom. This operation is easier fitting into the main frame at a slight angle [Fig.1].
- To facilitate boom insertion, you can also unscrew the two bolts that hold the tail servo support tray.
- * Tighten the M8 nut with HA016 special tool supplied.
- * After installation, connect the tail push rod.
- * To lock the nut and prevent it from coming loose, install:
 - H0287 (for FBL unit installed on the main plate) [Fig.2].
 - H0564 (for FBL unit installed on H0564) [Fig.3].

NOTE:

Fig. 1

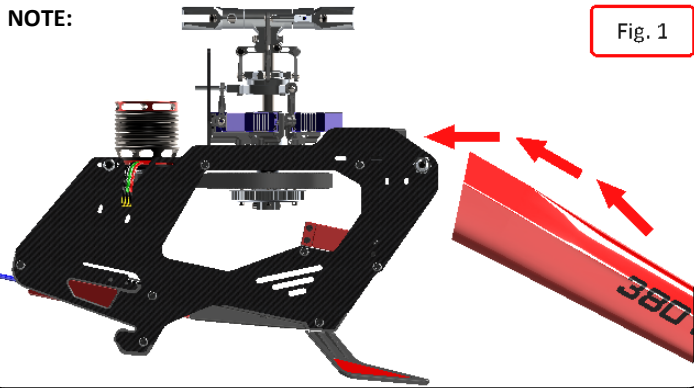

Nylon Screw
M8x14mm
(HC164-S)

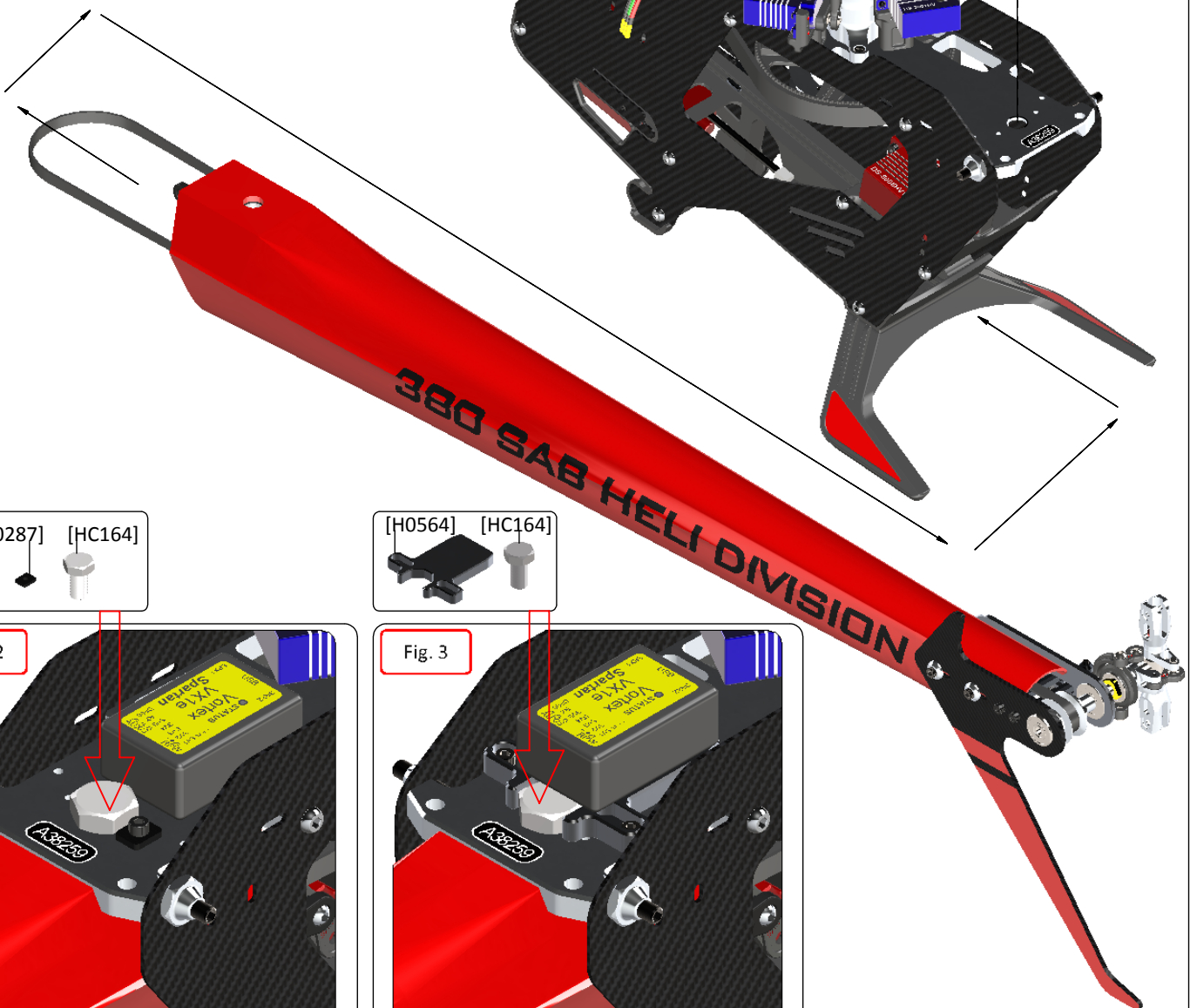

[H0287] [HC164]

[H0564] [HC164]

Fig. 2

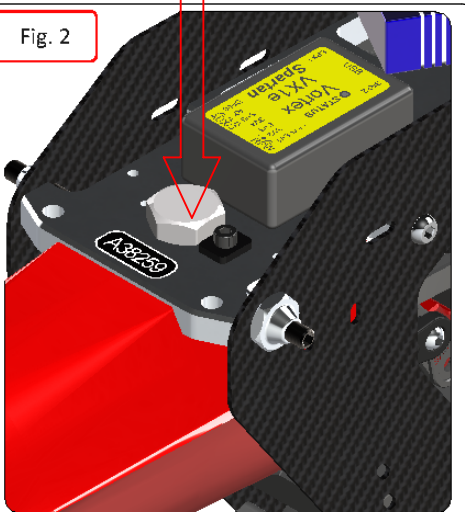
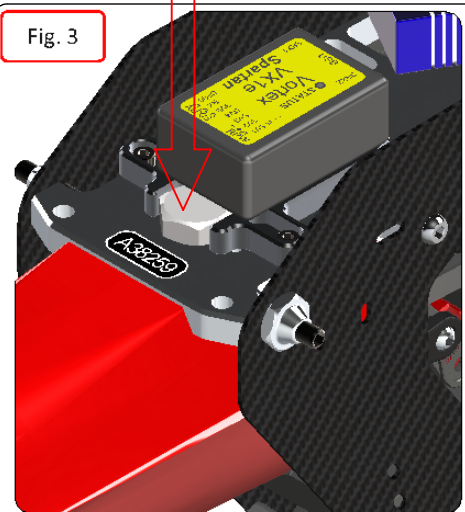

Fig. 3



TAIL BELT TENSION

- *Check for the proper assembly of the tail boom.
- *Loosen the tail case by loosening the 4 M2.5 screws.
- *Install the belt onto the front pulley in the correct direction of rotation (figure 1).
- *Rotate the tail drive several times by hand.
- *Pull the tail case back to increase belt tension.
- *Tighten the 4 M2.5 screws on the tail case.
- *The belt must be very tight.

Fig. 1



CANOPY

Fit the canopy to the main frame until it stops. [Fig. 2]
Fit the canopy holes to the M4 set screws on the model.

Check alignment of the edge on the boom [Fig. 3]
If the alignment is correct, enlarge the 2 canopy holes with a reamer up to 10 mm in diameter.
If alignment is not OK, enlarge the 2 canopy holes in the appropriate direction up to 10 mm in diameter.

Install the canopy grommets. [Fig. 4]

The canopy can be locked using the knobs H0543. [Fig. 5]

NOTE: If you want to use the rubber edge protector, you must increase the size of the opening in the canopy that goes around the anti-rotation guide by approximately 2 mm per side.

Fig. 5

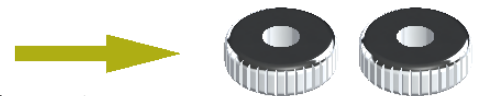

Fig. 2

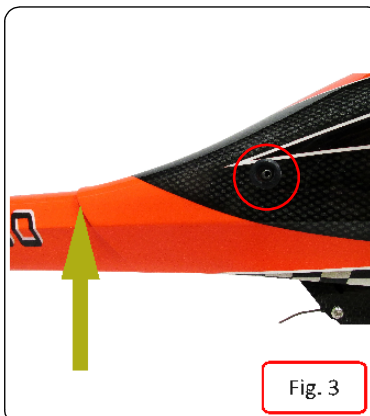

Fig. 3

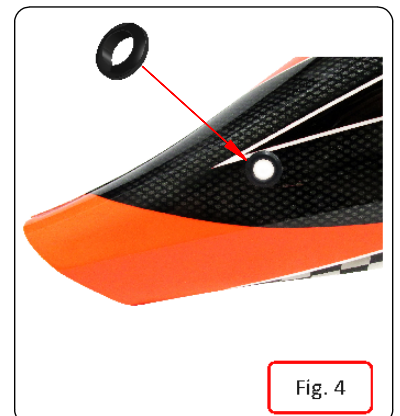

Fig. 4

BATTERIES

The Goblin has a quick release battery tray system.

The batteries must be installed onto the battery tray to take advantage of the quick release locking system.

Install the battery to the battery tray using double sided tape and the long Velcro straps included (Fig 1 and Fig 2).

Make sure to find the right position of the battery to optimize the center of gravity.

The battery wires arranged as in fig 2 are particularly effective.

To insert the battery, simply align the battery tray in the slots at the front of the helicopter and slide all the way. The battery will lock in place.

To remove the battery, simply lift up on the locking lever (Fig 5) and pull.

IMPORTANT:



Make sure the battery is locked in place before flight; the battery tray must be inside the slots on both sides!

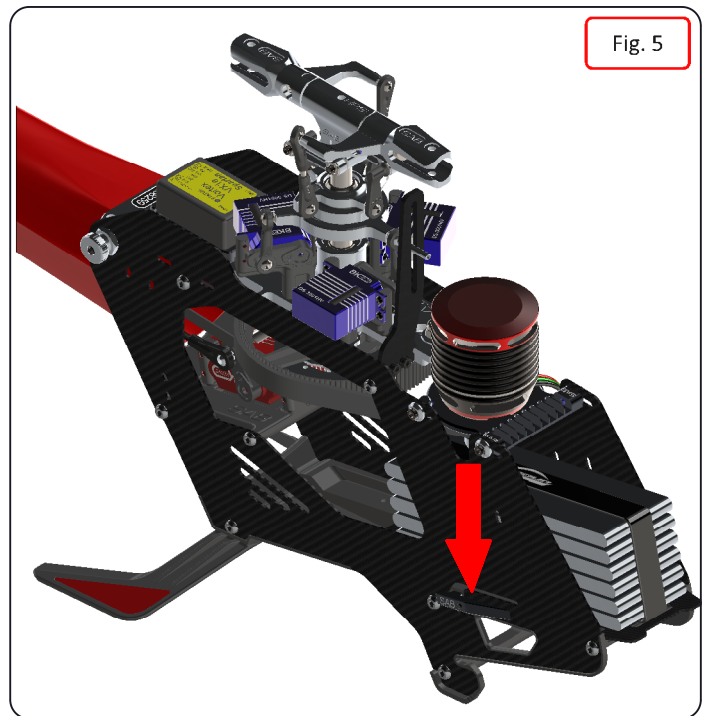
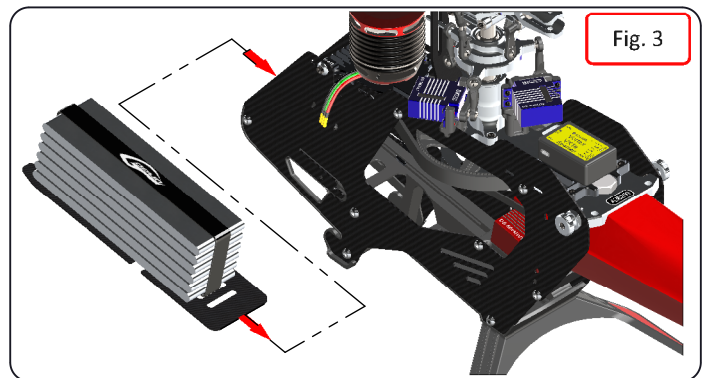
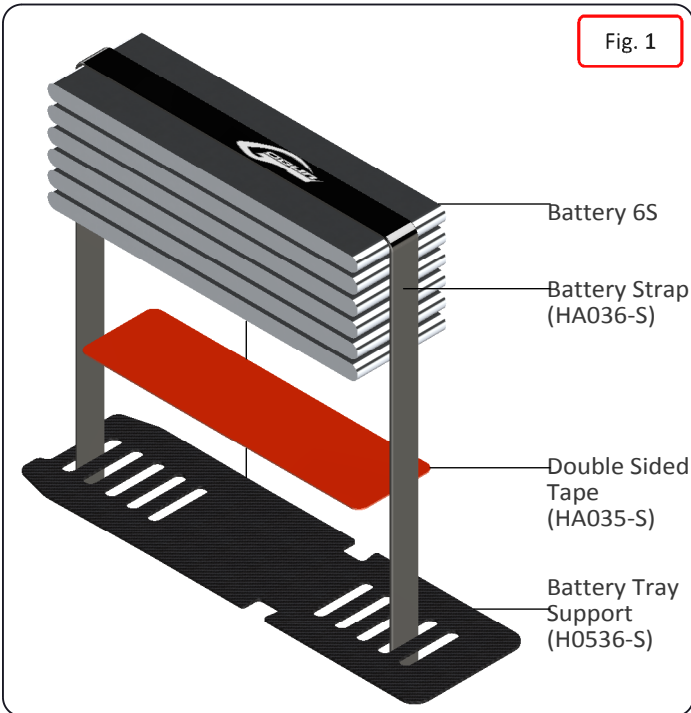

SERIAL NUMBER

In Bag 19, you will find the serial number tag for your Helicopter.

- ⚠ Apply the tag as shown. Please remember to register your product. (See page 1)



OPERATIONS BEFORE FLIGHT

- *Set up the transmitter and the flybarless system with utmost care.
- *It is advisable to test the correct settings of the transmitter and flybarless system without main blades and tail blades fitted.
- *Check that all wiring is isolated from the carbon/aluminum parts. It is good practice to protect them at the points where they are at most risk.
- ⚠ *Be sure of the gear ratio, verifying carefully the motor pulley in use. The forces acting on the mechanics increase enormously at higher RPM. Although the Goblin can fly at very high RPMs, for safety reasons we suggest to not exceed 3600 RPM.
- *Fit the main blades and tail blades. (Fig.1 and Fig.2)
- *Please make sure the main blades are tight on the blade grips, you should be able to violently jerk the head in both directions and the blades should not fold. Failure to tighten the blades properly can result in a boom strike during spool up. To fold the blades for storage, it is advisable to loosen them.
- *Check the collective and cyclic pitch. For 3D flight, set about +/- 12.5°.
- *It is important to check the correct tracking of the main blades. (Fig 3).
- ⚠ *Perform the first flight at a low head speed, 2500/2600 RPM.
- ⚠ After this first flight, do a general check of the helicopter. Verify that all screws and bolts are correctly tightened.

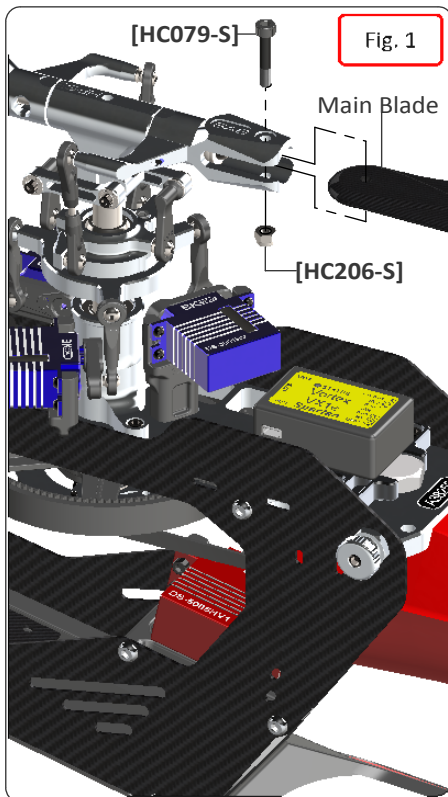

Fig. 1

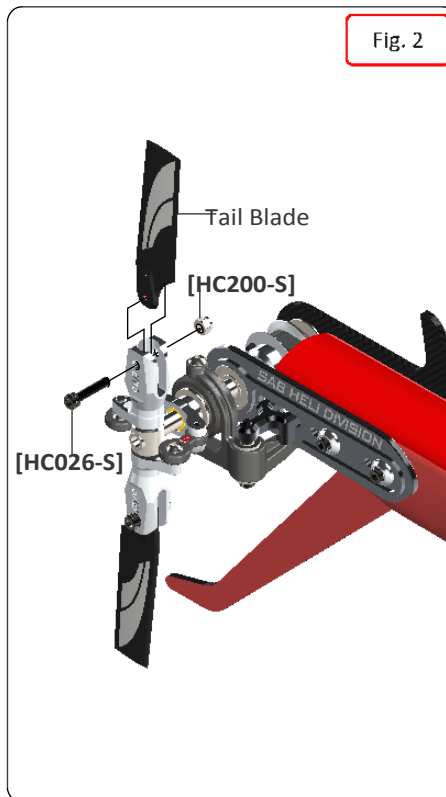

Fig. 2

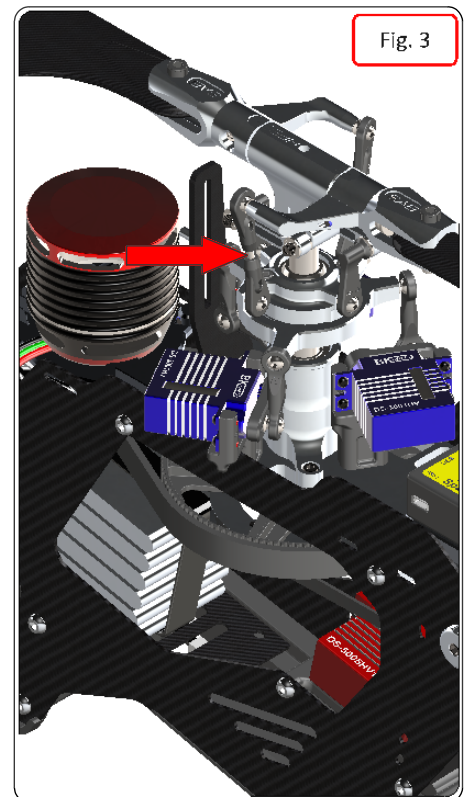

Fig. 3

IN FLIGHT

It's very important to check the model thoroughly after the first 2-3 flights. Check all bolts, screws, belts, ball links, etc.
 If the model is making strange noises, this can be usually attributed to incorrect belt tensions. Check the belts again and tighten if necessary.

MAINTENANCE

*On the Goblin 380, some areas to look for wear include:

- Motor belt
- Tail belt
- Dampers

*The most stressed bearings are definitely those on the tail shaft and the thrust bearings. Check them frequently. All other parts are not particularly subject to wear.

Fig. 1

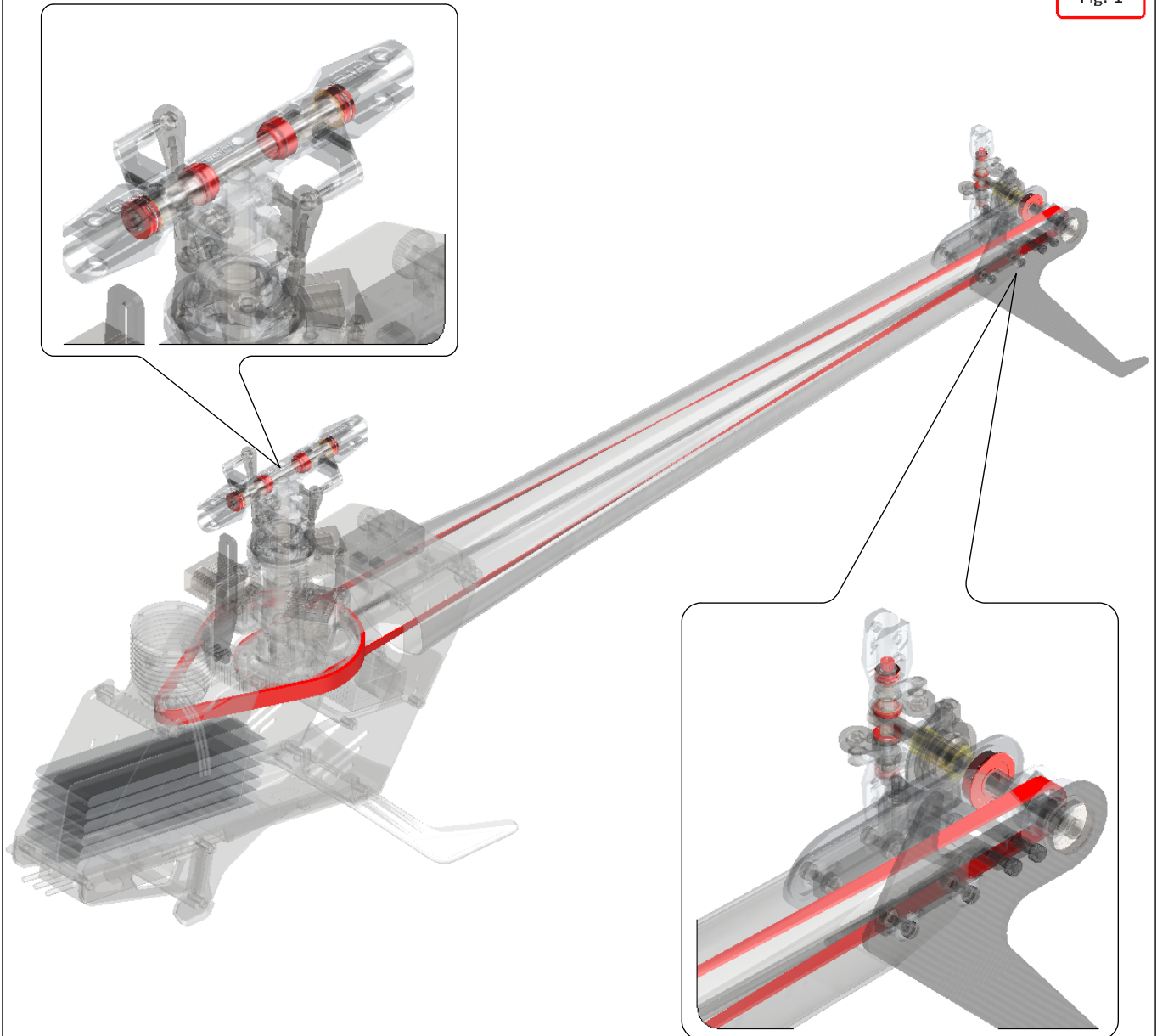

*The lifespan of these components varies according to the type of flying. On average it is recommended to check these parts every **20** flights. In some instances, based on wear, these parts should be replaced every **100** flights.

*Periodically lubricate the tail slider movement and its linkages as well as the swash plate movement and its linkages.

*To ensure safety you should do a general inspection of the helicopter after each flight. You should check:

- Proper belt tension (motor belt and tail belt).
- Proper isolation of the wires from the carbon and aluminum parts.
- All screws and bolts remain tight.



Main Frame				
POS	COD	Name	Specification	Quantity
1	H0255	Finishing Washers M2.5	Aluminum	2
2	H0528	Plastic Lading Gear	Plastic	1
3	H0529	Plastic Battery Support	Plastic	1
4	H0530	Tail Servo Support	Plastic	1
5	H0531	Main Frame	Carbon Fiber	2
6	H0536	Battery Tray Support	Carbon Fiber	1
7	H0539	Battery Aluminum Block	Aluminum	1
8	HC005	Button Head Cap Screws	M2x5mm	1
9	HC019	Button Head Cap Screws	M2.5x6mm	12
10	HC022	Socket Head Cap Screws	M2.5x10mm	2
11	HA035	Double Sided Tape		1
12	HA036	Battery Strap		1

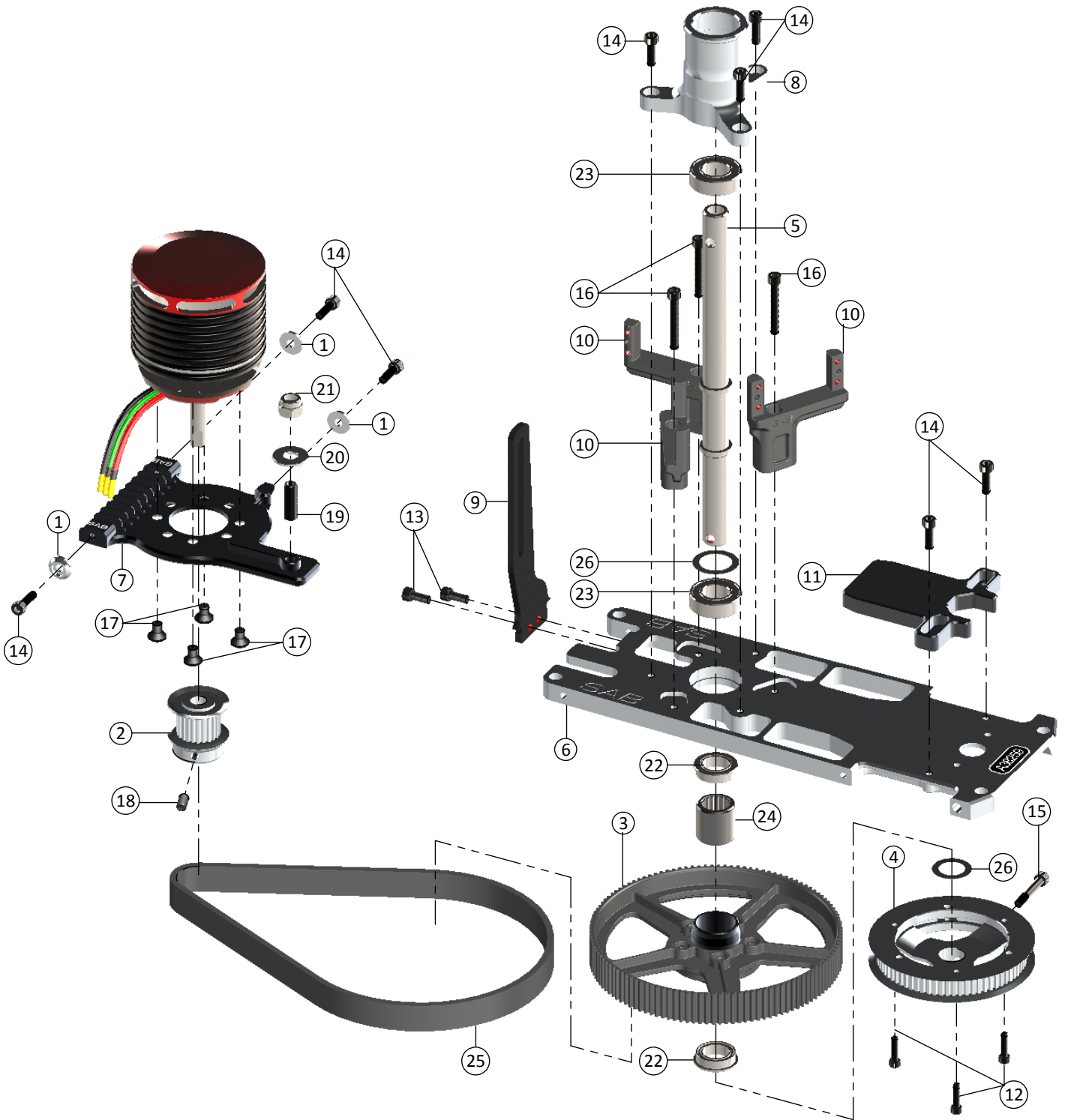

TRANSMISSION ASSEMBLY				
POS	COD	Name	Specification	Quantity
1	H0255	Fnishing Washer M2.5	Aluminum	3
2	H0501	21T Motor Pulley ASM	Aluminum	1
3	H0502	120T Main Pulley	Aluminum	1
4	H0503	Fonrt Tail Pulley ASM	Aluminum	1
5	H0507	Main Shaft	Steel	1
6	H0519	Main Plate	Aluminum	1
7	H0520	Motor Support	Aluminum	1
8	H0522	Main Shaft Support	Steel	1
9	H0533	CF Anti-Rotation Guide	Carbon Fiber	1
10	H0548	Plastic Servo Support	Plastic	3
11	H0564	Flybarless Support	Aluminum	1
12	HC008	Socket Head Cap Screws	M2x8mm	3
13	HC018	Socket Head Cap Screws	M2.5x6mm	2

TRANSMISSION ASSEMBLY				
POS	COD	Name	Specification	Quantity
14	HC020	Socket Head Cap Screws	M2.5x8mm	8
15	HC031	Head Cap Screws Shouldered	M2.5x15mm	1
16	HC032	Socket Head Cap Screws	M2.5x18mm	3
17	HC132	Flat Head Cap Screws	M3x5mm	4
18	HC144	Cone Point Set Screws	M3x6mm	1
19	HC153	Cone Point Set Screws	M4x12mm	1
20	HC184	Washers	Ø 4.3x Ø 11x1mm	1
21	HC212	Metrix Nylon Nut	M4	1
22	HC418	Flanged Bearing	Ø 8x Ø 12x3.5mm	1
23	HC419	Bearing	Ø 8x Ø 16x5mm	2
24	HC440	One Way Bearing	Ø 8x Ø 12x12mm	2
25	HC454	Motor Belt	304-2GT-09	1
26	HC462	Shim Washers	Ø 8x Ø 12x0.2mm	2

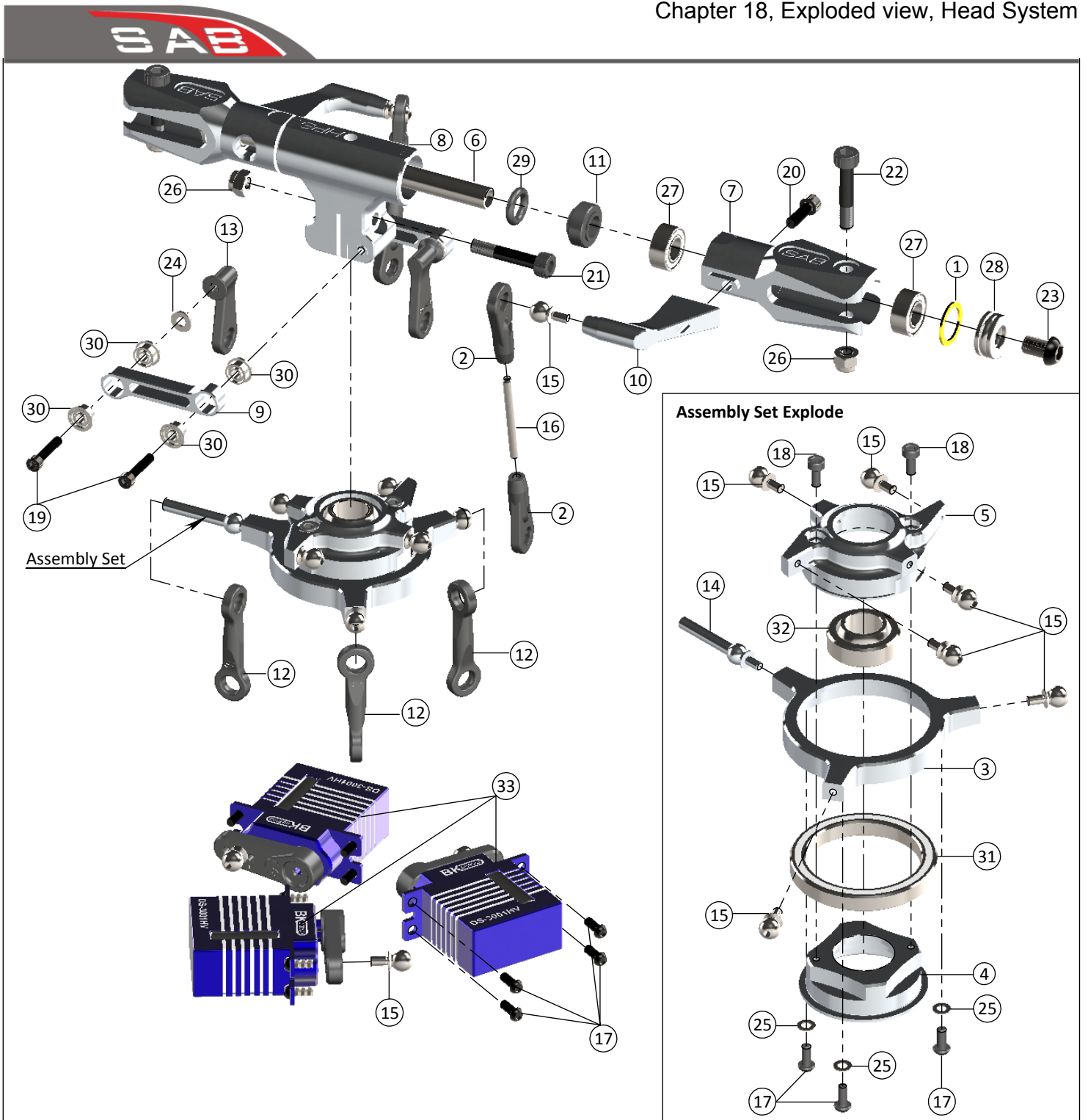

HEAD SYSTEM				
POS	COD	Name	Specification	Quantity
1	H0349	Washer	Ø 7,5x Ø 10x0,5	2
2	H0403	Plastic Linkage Ball	M2	4
3	H0506-01	Swashplate 01	Aluminum	1
4	H0506-02	Swashplate 02	Aluminum	1
5	H0506-03	Swashplate 03	Aluminum	1
6	H0508	Main Spindle	Steel	1
7	H0513	Main Blade Grip	Aluminum	2
8	H0514	Main HUB	Aluminum	1
9	H0516	Swashplate Arm	Aluminum	2
10	H0517	Main Blade Grip Arm	Aluminum	2
11	H0518	Damper	Plastic	2
12	H0524	Linkage Servos	Plastic	3
13	H0525	Radius Plastic Arm	Plastic	2
14	H0537	Uniball M2 Female	Aluminum	1
15	H0538	Uniball M2 Male	Steel	11
16	H0561	Linkage	M2x22mm	2
17	HC005	Button Head Cap Screw	M2x5mm	15

HEAD SYSTEM				
POS	COD	Name	Specification	Quantity
18	HC008	Socket Head Cap Screws	M2 x 8mm	2
19	HC010	Socket Head Cap Screws	M2 x 10mm	4
20	HC020	Socket Head Cap Screws	M2.5 x 8mm	2
21	HC074	Head Cap Screws Shoulder	M3 x 16mm	1
22	HC079	Head Cap Screws Shoulder	M3 x 18mm	2
23	HC096	Button Head Cap Screws	M4 x 6mm	2
24	HC170	Washers	Ø 2.1x Ø 5 x 0.5	2
25	HC172	Washers	Ø 2.2x Ø 4x0.3	3
26	HC206	Metric Hex Nylon Nuts	M3	3
27	HC411	Bearing	Ø 5x Ø 10x4	4
28	HC435	Thrust Bearing	Ø 5x Ø 10x4	2
29	HC453	Oring	DI=6,75, S=1,78	2
30	HC456	Flanged Bearing	Ø 2x Ø 5x2.5	8
31	HC459	Rad Bearing	Ø 25x Ø 32x4	1
32	HC460	Spherical Bearing	Ø 12x Ø 22x7	1
33		DS-3001HV	BK Servo	3

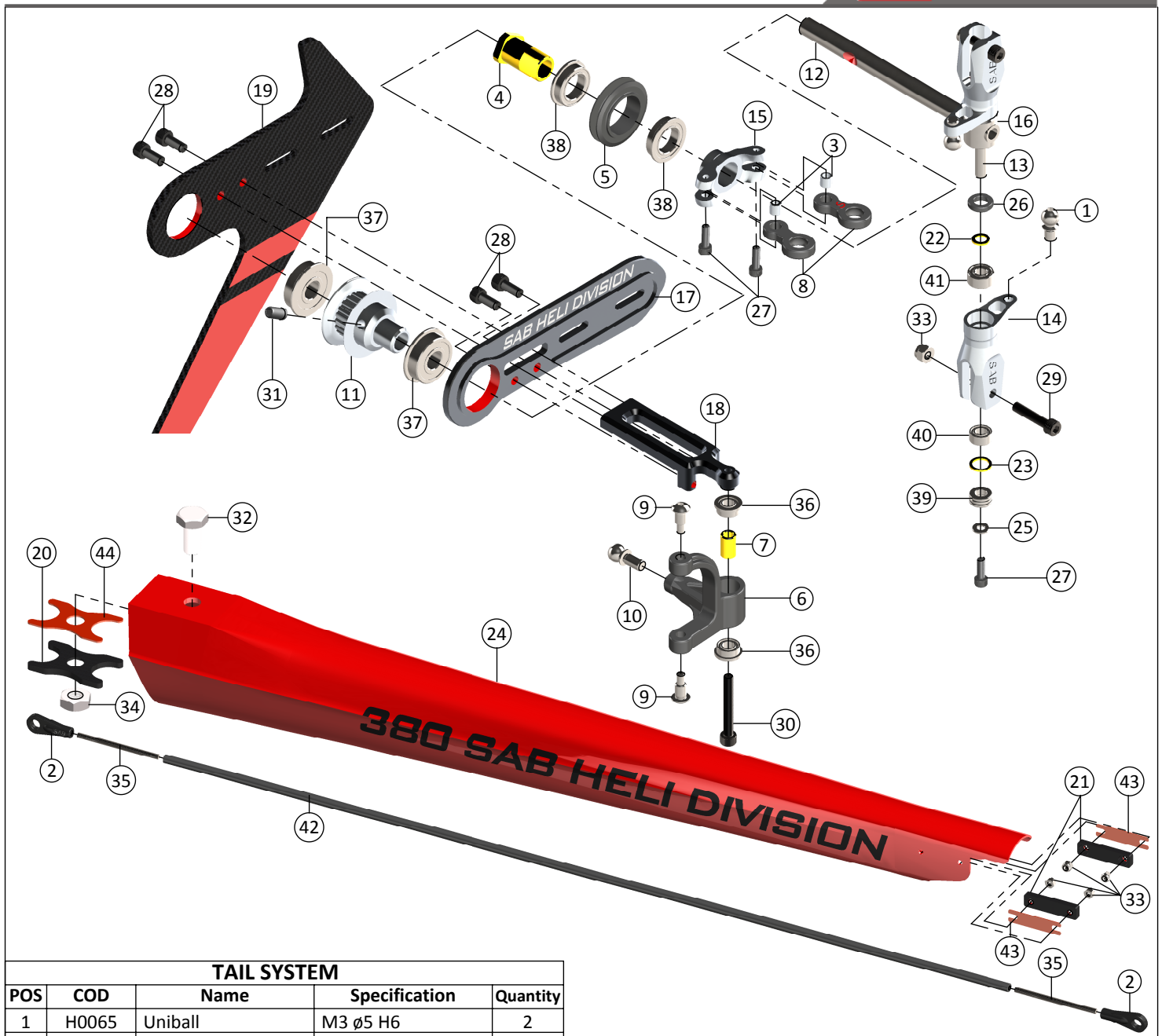

TAIL SYSTEM				
POS	COD	Name	Specification	Quantity
1	H0065	Uniball	M3 ø5 H6	2
2	H0066	Plastic Ball Link	M2,5	2
3	H0076	Grip Link Bushing	Brass	2
4	H0231	Tail Pitch Slider 01	Aluminum	1
5	H0232	Tail Pitch Slider 02	Aluminum	1
6	H0234	Bell Crank Lever	Plastic	1
7	H0253	Spacer Arm	ø2.5ø4x6.3	1
8	H0261	Tail Pitch Slider Link	Plastic	2
9	H0264	Tail Pin	Steel	2
10	H0279	Uniball	M3 ø5 H11.5	1
11	H0505	21T Tail Pulley	Aluminum	1
12	H0509	Tail Shaft	Steel	1
13	H0510	Tail Spindle	Steel	1
14	H0511	Tail Blade Grip	Aluminum	2
15	H0512	Tail Slider	Aluminum	1
16	H0515	Tail Hub	Steel	1
17	H0523	Tail Side Plate	Aluminum	1
18	H0526	Cros Tail Case	Aluminum	1
19	H0532	Vertical Fin	Carbon Fiber	1
20	H0534	CF Nut M8 Block	Carbon Fiber	1
21	H0535	Locking Element Tail	Carbon Fiber	2
22	H0540	Washer	ø3ø4.75x0.5	2
23	H0541	Washer	ø4.5ø5.9x0.5	2
24	H0546	Red Tail Boom	Carbon Fiber	1

TAIL SYSTEM				
POS	COD	Name	Specification	Quantity
25	H0566	Washer	ø2ø4.5x0.5	2
26	H0567	Tail Damper	Derlin	2
27	HC004	Socket Head Cap Screws	M2 x 6mm	4
28	HC018	Socket Head Cap Screws	M2.5 x 6mm	4
29	HC026	Socket Head Cap Screws	M2.5 x 12mm	2
30	HC032	Socket Head Cap Screws	M2.5 x 18mm	1
31	HC144	Cone Point Set Screws	M3 x 6mm	1
32	HC164	Nylon Screws	M8 x 14mm	1
33	HC200	Nylon Nut	M2.5	6
34	HC224	Nylon Nut	M8	1
35	HC242	Threaded Rod	M2.5x40mm	2
36	HC400	Bearing	ø2.5ø6x2.5	2
37	HC412	Flanged Bearing	ø5ø13x4	2
38	HC416	Flanged Bearing	ø7ø11x2.5	2
39	HC448	Thrust Bearing	ø3ø6x2.5	2
40	HC457	Bearing	ø3ø6x2.5	2
41	HC458	Bearing	ø3ø7x3	2
42	HC461	Carbon Rod		1
43	HA033	Double Sided Tape		2
44	HA034	Double Sided Tape		1

**Uniball M2 ϕ 5H6
[H0064-S]**



- 5 x Uniballs M2 ϕ 5H6.
- 5 x Uniball Spacers.
- 5 x Socket Head Cap Screws M2x8mm.
- 5 x Socket Head Cap Screws M2x6mm.

**Uniball M3x4 ϕ 5H3
[H0065-S]**



- 5 x Uniballs M3x4 ϕ 5H3.5.

**Plastic Ball Link
[H0066-S]**



- 10 x Plastic Ball Link.

**Bell Crank Lever
[H0234-S]**



- 1 x Bell Crank level.
- 2 x Tail Pin.
- 2 x Flanged Bearing ϕ 2.5x ϕ 6x2.5mm.
- 1 x Spacer Arm ϕ 2.5x ϕ 4x6.3.
- 1 x Head Cap Screws M2.5x18.
- 1 x Uniball M3x ϕ 4 H5.

**Finishing Washer M2.5
[H0255-S]**



- 10 x Finishing Washer M2.5.

**Tail Pitch Slider Link
[H0261-S]**



- 2 x Tail Pitch Slider Link.
- 2 x Spacer ϕ 2x ϕ 3x3mm.
- 2 x Socket Head Cap M2x6mm.

**Plastic Ball Link M2
[H0403-S]**



- 5 x Plastic Ball Link M2.

**19T Motor Pulley
[H0501-19-S]**



- 1 x 19T Motor Pulley Assembly.
- 1 x Set Screws M3x6mm.

**20T Motor Pulley
[H0501-20-S]**



- 1 x 20T Motor Pulley Assembly.
- 1 x Set Screws M3x6mm.

**21T Motor Pulley
[H0501-21-S]**



- 1 x 21T Motor Pulley Assembly.
- 1 x Set Screws M3x6mm.

**22T Motor Pulley
[H0501-22-S]**



- 1 x 22T Motor Pulley Assembly.
- 1 x Set Screws M3x6mm.

**19T Motor Pulley
[H0501-23-S]**



- 1 x 23T Motor Pulley Assembly.
- 1 x Set Screws M3x6mm.

**24T Motor Pulley
[H0501-24-S]**



- 1 x 24T Motor Pulley Assembly.
- 1 x Set Screws M3x6mm.

**25T Motor Pulley
[H0501-25-S]**



- 1 x 25T Motor Pulley Assembly.
- 1 x Set Screws M3x6mm.

**120T Main Pulley
[H0502-S]**



- 1 x 120T Main Pulley .
- 1 x Main Pulley Support.
- 2 x Shims ϕ 8x ϕ 14x0,2mm.
- 5 x Head Cap Screws M2x5mm.
- 2 x Flanged Bearing ϕ 8x ϕ 12x3,5mm.
- 1 x One Way Bearing ϕ 8x ϕ 12x12mm.

**Front Tail Pulley
[H0503-S]**

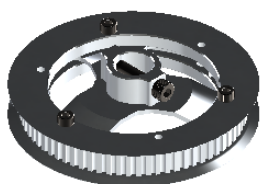

- 1 x Front Tail Pulley Assembly.
- 1 x Head Cap Screws Shoulder M2.5x15.
- 3 x Head Cap Screws M2x8.

**20T Tail Pulley
[H0504-S]**

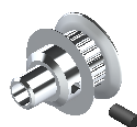

- 1 x 20T Tail Pulley Assembly.
- 1 x Set Screws M3x6mm.

**Washplate Set
[H0506-S]**















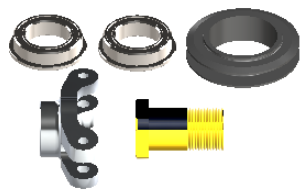

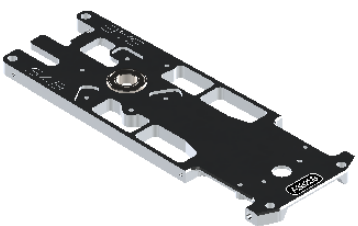
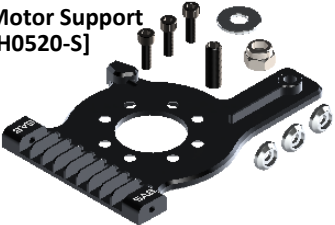

- 1 x Swashplate Assembly.
- 1 x Rad Bearings ϕ 25x ϕ 32x4.
- 6 x Uniballs M2 Male.
- 1 x Uniballs M2 Female.
- 3 x Button Cap Screws M2x5.
- 3 x Swasher ϕ 2.2x ϕ 4x0.3.
- 2 x Head Cap Screws M2x8.

**Main Shaft
[H0507-S]**

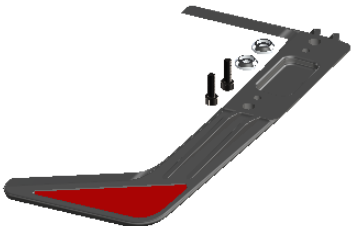
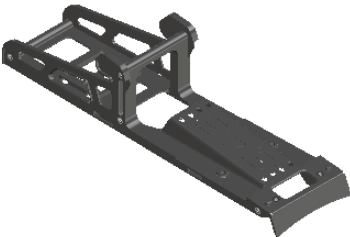

- 1 x Main Shaft.
- 1 x Head Cap Screw M3x16mm.
- 1 x Metrix Nylon Nut M3.

<p>Spindle Shaft [H0508-S]</p>  <p>- 1 x Spindle Shaft. - 2 x Button Cap Screw M4x6mm.</p>	<p>Tail Shaft [H0509-S]</p>  <p>- 1 x Tail Shaft. - 1 x Tail Hub. - 1 x Set Screw M3x6mm. - 2 x Tail Damper.</p>	<p>Tail Spindle [H0510-S]</p>  <p>- 1 x Tail Spindle. - 1 x Socket Cap Screw M2x6mm. - 2 x Washer $\varnothing 2x\varnothing 4.5x0.5mm$.</p>	<p>Tail Blade Grip [H0511-S]</p>  <p>- 2 x Tail Blade Grip. - 2 x Thrust Bearing $\varnothing 3x\varnothing 6x2.5mm$. - 2 x Bearing $\varnothing 3x\varnothing 7x3mm$. - 2 x Bearing $\varnothing 3x\varnothing 6x2.5mm$. - 2 x Washer $\varnothing 3x\varnothing 4.75x0.5mm$. - 2 x Washer $\varnothing 4.5x\varnothing 5.9x0.5mm$. - 2 x Washer $\varnothing 2x\varnothing 4.5x0.5mm$. - 2 x Uniball M3.</p>
<p>Tail Pitch Slider [H0512-S]</p>  <p>- 1 x Tail Pitch Slider 01. - 1 x Tail Pitch Slider 02. - 1 x Tail Pitch Slider 03. - 2 x Flanged Bearings $\varnothing 8x\varnothing 12x3.5mm$.</p>	<p>Main Blade Grip [H0513-S]</p>  <p>- 2 x Blade Grip. - 2 x Thrust Bearing $\varnothing 5x\varnothing 10x4$. - 4 x Bearing $\varnothing 5x\varnothing 10x4$. - 2 x Washer $\varnothing 7.5x\varnothing 10x0.5$. - 2 x Button Head Socket Cap M4x6. - 2 x Washer $\varnothing 5x\varnothing 7x0.1$.</p>	<p>Center Hub [H0514-S]</p>  <p>- 1 x Center Hub. - 1 x Socket Head Shoulder M3x16. - 1 x Metrix Hex Nylon Nut M3.</p>	
<p>Radius Arm [H0516-S]</p>  <p>- 2 x Radius Arms. - 2 x Uniball Radius Arms. - 4 x Head Cap Screws M2x10mm. - 8 x Flanged Bearings $\varnothing 2x\varnothing 5x2.5$. - 2 x Washer $\varnothing 2.1x\varnothing 5x0.5mm$.</p>	<p>Blade Grip Arm [H0517-S]</p>  <p>- 2 x Blade Grip Arm. - 2 x Head Cap Screws M2.5x8. - 2 x Uniball M2.</p>	<p>Damper Derlin [H0518-S]</p>  <p>- 2 x Damper Derlin. - 2 x Oring DI = 6.75, S = 1.78. - 2 x Washer $\varnothing 7.5x\varnothing 10x0.5$. - 2 x Button Head Cap M4x6. - 2 x Washer $\varnothing 5x\varnothing 7x0.1$.</p>	<p>Main Plate [H0519-S]</p>  <p>- 1 x Main Plate. - 1 x Bearing $\varnothing 8x\varnothing 16x5$.</p>
<p>Motor Support [H0520-S]</p>  <p>- 1 x Motor Support. - 3 x Head Cap Screws M2.5x8. - 3 x Finishing Washer M2.5. - 1 x Set Screws M4x12. - 1 x Metrix Hex Nylon Nut M4. - 1 x Washer $\varnothing 4x\varnothing 11x1mm$.</p>	<p>Main Shaft Support [H0522-S]</p>  <p>- 1 x Main Shaft Support. - 3 x Head Cap Screws M2.5x8. - 1 x Bearing $\varnothing 8x\varnothing 16x5$.</p>	<p>Aluminum Tail Plate [H0523-S]</p>  <p>- 1 x Aluminum Tail Plate. - 1 x Flanged Bearing $\varnothing 5x\varnothing 13x4$. - 2 x Head Cap Screws M2.5x10. - 2 x Finishing Washer M3.</p>	<p>Linkage Servo [H0524-S]</p>  <p>- 3 x Aluminum Tail Plate.</p>
<p>Plastic Radius Arm [H0525-S]</p>  <p>- 2 x Plastic Radius Arm. - 2 x Washer $\varnothing 2.2x\varnothing 5x0.3mm$.</p>	<p>Cros Tail Case [H0526-S]</p>  <p>- 1 x Cros Tail Case. - 2 x Head Cap Screw M2.5x6.</p>	<p>Plastic Landing Gear [H0528-S]</p>  <p>- 1 x Plastic Landing Gear. - 2 x Head Cap Screw M2.5x8. - 2 x Finishing Washer M2.5.</p>	<p>Plastic Battery Support [H0529-S]</p>  <p>- 1 x Plastic Battery Support.</p>



Tail Servo Support (H0530-S)



- 1 x Tail Servo Support.

Main Frame (H0531-S)

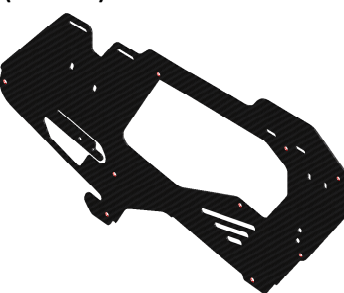

- 1 x Main Frame.

Vertical Fin (H0532-S)



- 1 x Vertical Fin.
- 2 x Finishing Washer M3.
- 2 x Head Cap Screws M2.5x6.
- 2 x Head Cap Screws M2.5x10.

Anti-Rotation Guide (H0533-S)



- 1 x Anti-Rotation Guide.
- 2 x Head Cap Screws M2.5x6.

Boom Accessories (H0535-S)



- 1 x M8 Carbon Block.
- 2 x Locking Element Tail.
- 1 x Double Sided Tape [HA034].
- 1 x Double Sided Tape [HA033].
- 1 x Metrix Hex Nylon Nut M8.
- 1 x Metrix Hex Nylon Screw M8.
- 4 x Metrix Hex Nylon Nut M2.5.

Battery Tray (H0536-S)

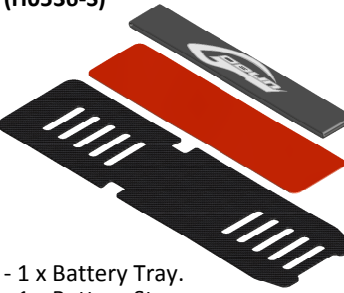

- 1 x Battery Tray.
- 1 x Battery Straps.
- 1 x Double Sided Tape [HA036].

Uniball M2 Female (H0537-S)



- 2 x Uniball M2 Female.

Uniball M2 Male (H0538-S)



- 5 x Uniball M2 Male.

Battery Block (H0539-S)



- 1 x Battery Block.
- 1 x Button Cap Screws M2x5.

Tail Spacer KIT (H0540-S)



- 2 x Washer $\varnothing 3 \times \varnothing 4.75 \times 0.5$.
- 2 x Washer $\varnothing 4.5 \times \varnothing 5.9 \times 0.5$.
- 2 x Washer $\varnothing 2 \times \varnothing 4.5 \times 0.5$.
- 2 x Oring ID=2.9, S=1.78.
- 2 x Head Cap Screw M2x6mm.

Canopy Nut (H0542-S)



- 2 x Canopy Nut.
- 2 x Set Screws M4x20mm.

Canopy Knob (H0543-S)



- 2 x Canopy Knob.

Yellow/Blue Canopy (H0544-S)



- 1 x Yellow/Blue Canopy.
- 1 x Canopy Edge Protection.
- 2 x Canopy Grommet.

Red/Black Canopy (H0545-S)



- 1 x Red/Black Canopy.
- 1 x Canopy Edge Protection.
- 2 x Canopy Grommet.

Yellow Boom (H0546-S)





- 1 x Yellow Tail Boom.
- 1 x M8 Carbon Block.
- 2 x Locking Element Tail.
- 1 x Double Sided Tape [HA034].
- 1 x Double Sided Tape [HA033].
- 1 x Metrix Hex Nylon Nut M8.
- 1 x Metrix Hex Nylon Screw M8.
- 4 x Metrix Hex Nylon Nut M2.5.

Red Boom (H0547-S)





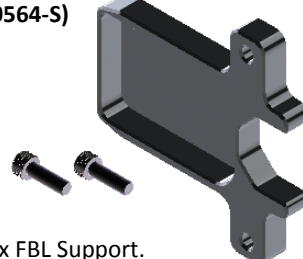
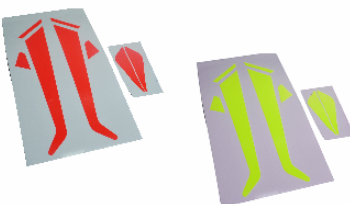







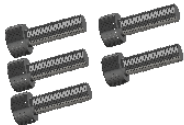
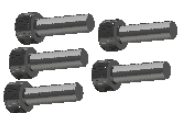











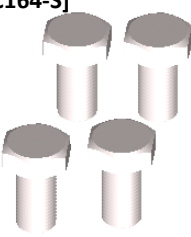
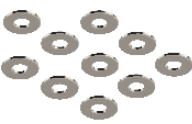









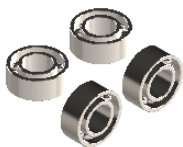
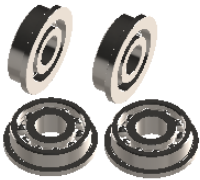

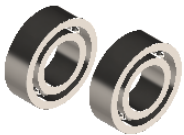



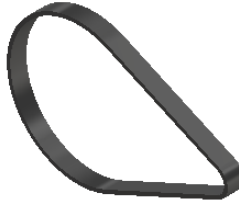





- 1 x Red Tail Boom.
- 1 x M8 Carbon Block.
- 2 x Locking Element Tail.
- 1 x Double Sided Tape [HA034].
- 1 x Double Sided Tape [HA033].
- 1 x Metrix Hex Nylon Nut M8.
- 1 x Metrix Hex Nylon Screw M8.
- 4 x Metrix Hex Nylon Nut M2.5.

<p>Plastic Servo Support (H0548-S)</p>  <p>- 1 x Plastic Servo Support. - 1 x Head Cap Screws M2.5x18mm.</p>	<p>Linkage Rod M2 (H0561-S)</p>  <p>- 2 x Linkage Rod M2x22mm. - 4 x Plastic Ball Link M2.</p>	<p>FBL Support (H0564-S)</p>  <p>- 1 x FBL Support. - 2 x Head Cap Screw M2.5x8mm.</p>	<p>Tail Fin and Landing Gear Stickers (H0565-S)</p>  <p>- 2 x Tail Fin Stickers. - 2 x Landing Gear Stickers.</p>
--	--	---	---

<p>Tail Servo Spacer (H0572-S)</p>  <p>- 4 x Tail Servo Spacer.</p>

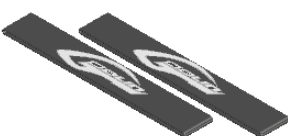
STANDARD SPARE PARTS

<p>[HC002-S]</p>  <p>- 5 x Socket Head Cap M2x5mm.</p>	<p>[HC004-S]</p>  <p>- 5 x Socket Head Cap M2x6mm.</p>	<p>[HC005-S]</p>  <p>- 5 x Button Head Cap M2x5mm.</p>	<p>[HC008-S]</p>  <p>- 5 x Socket Head Cap M2x8mm.</p>	<p>[HC010-S]</p>  <p>- 5 x Socket Head Cap M2x10mm.</p>
<p>[HC018-S]</p>  <p>- 5 x Socket Head Cap M2.5x6mm.</p>	<p>[HC019-S]</p>  <p>- 5 x Button Head Cap Special M2.5x6mm.</p>	<p>[HC020-S]</p>  <p>- 5 x Socket Head Cap M2.5x8mm.</p>	<p>[HC022-S]</p>  <p>- 5 x Socket Head Cap M2.5x10mm.</p>	<p>[HC026-S]</p>  <p>- 5 x Socket Head Cap M2.5x12mm.</p>
<p>[HC031-S]</p>  <p>- 5 x Socket Head Cap Shoulder M2.5x15mm.</p>	<p>[HC032-S]</p>  <p>- 5 x Socket Head Cap M2.5x18mm.</p>	<p>[HC074-S]</p>  <p>- 2 x Socket Head Cap Shoulder M3x16mm. - 2 x Metrix Nylon Nut M3.</p>	<p>[HC096-S]</p>  <p>- 5 x Button Head Cap Screws M4x6mm.</p>	<p>[HC144-S]</p>  <p>- 5 x Cone Point Set Screw M3x6mm.</p>
<p>[HC155-S]</p>  <p>- 5 x Cone Point Set Screw M4x20mm.</p>	<p>[HC156-S]</p>  <p>- 5 x Cone Point Set Screw M4x12mm.</p>	<p>[HC164-S]</p>  <p>- 4 x Nylon Hex Nut M8x14mm.</p>	<p>[HC170-S]</p>  <p>- 10 x Washer Ø2,2xØ5x0,3mm.</p>	<p>[HC184-S]</p>  <p>- 5 x Washer Ø4,3xØ11x1mm.</p>

<p>[HC200-S]</p>  <p>- 10 x Metrix Nylon Nut M2.5.</p>	<p>[HC206-S]</p>  <p>- 10 x Metrix Nylon Nut M3.</p>	<p>[HC212-S]</p>  <p>- 10 x Metrix Nylon Nut M4.</p>	<p>[HC224-S]</p>  <p>- 4 x Metrix Nylon Nut M8.</p>	<p>[HC228-S]</p>  <p>- 4 x Shim Ø8xØ14x0,2mm.</p>
<p>[HC242-S]</p>  <p>- 3 x Thread Rod M2,5x40mm.</p>	<p>[HC400-S]</p>  <p>- 4 x Flanged Bearing Ø2.5xØ6x2.6mm.</p>	<p>[HC411-S]</p>  <p>- 4 x Bearing Ø5xØ10x4mm.</p>	<p>[HC412-S]</p>  <p>- 4 x Flanged Bearing Ø5xØ13x4mm.</p>	<p>[HC416-S]</p>  <p>- 2 x Flanged Bearing Ø7xØ11x2.5mm.</p>
<p>[HC418-S]</p>  <p>- 2 x Flanged Bearing Ø8xØ12x3.5mm.</p>	<p>[HC419-S]</p>  <p>- 2 x Bearing Ø8xØ16x5mm.</p>	<p>[HC435-S]</p>  <p>- 2 x Thrust Bearing Ø5xØ10x4mm.</p>	<p>[HC440-S]</p>  <p>- 1 x One Way Bearing Ø8xØ12x12mm.</p>	<p>[HC448-S]</p>  <p>- 2 x Thrust Bearing Ø3xØ6x2.5mm.</p>
<p>[HC450-S]</p>  <p>- 5 x Washer Ø5xØ7x0.1mm.</p>	<p>[HC453-S]</p>  <p>- 2 x Oring DI=6,75, S=1,78. - 2 x Oring DI=2.9, S=1,78.</p>	<p>[HC454-S]</p>  <p>- 1 x Belt 304-2GT-09.</p>	<p>[HC455-S]</p>  <p>- 1 x Belt 1140-HTD-2.</p>	<p>[HC456-S]</p>  <p>- 4 x Flanged Bearing Ø2xØ5x2.5mm.</p>
<p>[HC457-S]</p>  <p>- 4 x Bearing Ø3Ø6x2.5mm.</p>	<p>[HC458-S]</p>  <p>- 4 x Bearing Ø3Ø7x3mm.</p>	<p>[HC459-S]</p>  <p>- 1 x Rad Bearing Ø25Ø32x4mm.</p>	<p>[HC460-S]</p>  <p>- 1 x Spherical Bearing Ø12xØ22x7mm.</p>	<p>[HC461-S]</p>  <p>- 1 x Tail Push Rod Ø4xØ2,5x420mm. - 2 x Plastic Ball Link. - 2 x Thread Rod M2,5.</p>
<p>[HC462-S]</p>  <p>- 4 x Shim Ø8xØ12x0.1mm.</p>	<p>[HA016-S]</p>  <p>- 2 x Wrench Tool M8,M6.</p>	<p>[HA021-S]</p>  <p>- 4 x Canopy Grommet.</p>	<p>[HA032-S]</p>  <p>- 1 x Foam Blade Holder.</p>	<p>[HA035-S]</p>  <p>- 2 x Double-sided Tape 1 mm Battery.</p>
<p>[HA036-S]</p>  <p>- 2 x Battery Straps.</p>	<p>[HA052-S]</p>  <p>- 1 x Tail Servo Horn. - 3 x Cyclic Servo Horn.</p>	<p>[HA112-S]</p>  <p>- 1 x Canopy Edge Protection (1m).</p>	<p>[H0554-S]</p>  <p>- 2 x Tail Blade 70mm.</p>	<p>[BL380-3DS]</p>  <p>- 2 x Main Blade 380.</p>



- Carefully check your model before each flight to ensure it is airworthy.
- Consider flying only in areas dedicated to the use of model helicopters.
- Check and inspect the flying area to ensure it is clear of people or obstacles.
- Rotor blades can rotate at very high speeds! Be aware of the danger they pose.
- Always keep the model at a safe distance from other pilots and spectators.
- Avoid maneuvers with trajectories towards a crowd.
- Always maintain a safe distance from the model.



WWW.GOBLIN-HELICOPTER.COM

SAB HELI DIVISION