

HELICOPTER

MANUAL
GOBLIN FIREBALL



SAB HELI DIVISION

Please read this user manual carefully, it contains instructions for the correct assembly of the model.
Please refer to the web site www.goblin-helicopter.com for updates and other important information.

VERY IMPORTANT

In the Manual bag you will find a product card with your serial number. Please take a moment to register your kit online via our website:

<http://www.goblin-helicopter.com>

It is extremely important that you take a moment to register your helicopter with us. This is the only way to ensure that you are properly informed about changes to your kit, such as upgrades, retrofits and other important developments. SAB Heli Division cannot be held responsible for issues arising with your model and will not provide support unless you register your serial number.

The Serial number is also engraved in the Aluminum Main Plate.

Thank you for your purchase, we hope you enjoy your new Goblin helicopter!

SAB Heli Division

INDEX

1 – Serial Number	7 – Motor Assembly	14 – Flybarless control Unit and RX installation
2 – Important Notes	8 – Installation of the ESC	15 – Battery and Canopy
3 – Components and Box	9 – Assembly of the Motor	16 – Stickers
4 – Main Frame	10 – Installation of Tail Belt Tensioner	17 – In flight
5 – Tail System	11 – Installation of Swashplate Servos	18 – Maintenance
6 – Installation Of The Boom	12 – Head Sytem	19 – Spare Parts
	13 – Assembly of the Main Module	



SPECIFICATIONS

- Main rotor diameter : 626mm (with 280mm Main Blades)
- Tail rotor diameter : 139mm (with 50mm Tail Blades)
- Weight including standard electronics: 735g (excluding batteries)
- SAB Direct Driver motor included
- Micro size servo
- 50/60 A ESC
- Battery compartment: 34x42x75 mm



IMPORTANT NOTES

- *This radio controlled helicopter is not a toy.
- *This radio controlled helicopter can be very dangerous.
- *This radio controlled helicopter is a technically complex device which has to be built and handled very carefully.
- *This radio controlled helicopter must be built following these instructions. This manual provides the necessary information to correctly assemble the model. It is necessary to carefully follow all the instructions.
- *Inexperienced pilots must be monitored by expert pilots.
- *All operators must wear safety glasses and take appropriate safety precautions.
- *A radio controlled helicopter must only be used in open spaces without obstacles, and far enough from people to minimize the possibility of accidents or of injury to property or persons.
- *A radio controlled helicopter can behave in an unexpected manner, causing loss of control of the model, making it very dangerous.
- *Lack of care with assembly or maintenance can result in an unreliable and dangerous model.

***Neither SAB Heli Division nor its agents have any control over the assembly, maintenance and use of this product. Therefore, no responsibility can be traced back to the manufacturer. You hereby agree to release SAB Heli Division from any responsibility or liability arising from the use of this product.**

SAFETY GUIDELINES

- *Fly only in areas dedicated to the use of model helicopters.
- *Follow all control procedures for the radio frequency system.
- *It is necessary that you know your radio system well. Check all functions of the transmitter before every flight.
- *The blades of the model rotate at a very high speed; be aware of the danger they pose and the damage they may cause.
- *Never fly in the vicinity of other people.

DAMAGE LIMITS

SAB HELI DIVISION SHALL NOT BE LIABLE FOR SPECIAL, INDIRECT OR CONSEQUENTIAL DAMAGES, LOSS OF PROFITS OR PRODUCTION OR COMMERCIAL LOSS IN ANY WAY CONNECTED WITH THE PRODUCT, WHETHER SUCH CLAIM IS BASED IN CONTRACT, WARRANTY, NEGLIGENCE, OR STRICT LIABILITY. Further, in no event shall the liability of SAB Heli Division exceed the individual price of the Product on which liability is asserted. As SAB Heli Division has no control over use, setup, final assembly, modification or misuse, no liability shall be assumed nor accepted for any resulting damage or injury. By the act of use, setup or assembly the user accepts all resulting liability. If you as the Purchaser or user are not prepared to accept the liability associated with the use of this Product, you are advised to return this Product immediately in new and unused condition to the place of purchase.



LIMITED WARRANTY.

SAB Heli Division reserves the right to change or modify this warranty without notice and disclaims all other warranties, express or implied.

(a) This warranty is limited to the original Purchaser (“Purchaser”) and is not transferable. REPLACEMENT AS PROVIDED UNDER THIS WARRANTY IS THE EXCLUSIVE REMEDY OF THE PURCHASER This warranty covers only those Products purchased from an authorized SAB Heli Division dealer. Third party transactions are not covered by this warranty. Proof of purchase is required for warranty claims.

(b) Limitations- SAB HELI DIVISION MAKES NO WARRANTY OR REPRESENTATION, EXPRESS OR IMPLIED, ABOUT NONINFRINGEMENT, MERCHANTABILITY OR FITNESS FOR A PARTICULAR PURPOSE OF THE PRODUCT. THE PURCHASER ACKNOWLEDGES THAT THEY ALONE HAVE DETERMINED THAT THE PRODUCT WILL SUITABLY MEET THE REQUIREMENTS OF THE PURCHASER’S INTENDED USE.

(c) Purchaser Remedy- SAB Heli Division’s sole obligation hereunder shall be that SAB Heli Division will, at its option, replace any Product determined by SAB Heli Division to be defective In the event of a defect, this is the Purchaser’s exclusive remedy. Replacement decisions are at the sole discretion of SAB Heli Division. This warranty does not cover cosmetic damage or damage due to acts of God, accident, misuse, abuse, negligence, commercial use, or modification of or to any part of the Product. This warranty does not cover damage due to improper installation, operation, maintenance or attempted repair by anyone

NOTES FOR ASSEMBLY

Please refer to this manual for assembly instructions for this model. Follow the order of assembly indicated. The instructions are divided into chapters, which are structured in a way that each step is based on the work done in the previous step. Changing the order of assembly may result in additional or unnecessary steps.

Use thread lockers and retaining compounds as indicated. In general, each bolt or screw that engages with a metal part requires thread lock.

It is necessary to pay attention to the symbols listed below:

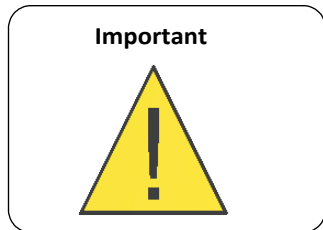

Important

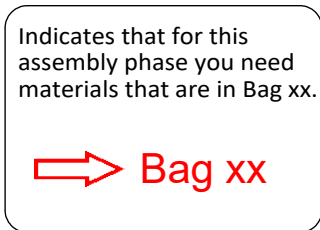

Indicates that for this assembly phase you need materials that are in Bag xx.

→ Bag xx

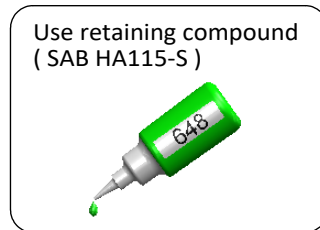

Use retaining compound (SAB HA115-S)



Use Thread Locker Medium Strength (SAB HA116-S)

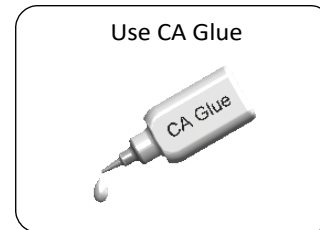

Use CA Glue



Use Proper Lubricant

ADDITIONAL COMPONENTS REQUIRED

SG280 GOBLIN FIREBALL

- *Speed controller: minimum 50A.
- *Batteries: 6S – 1000/1250mAh.
- *1 flybarless 3 axis control unit.
- *3 cyclic servos (Micro size).
- *1 tail rotor servo (Micro sizes).
- *6 channel radio control system on 2.4 GHz.

SG281 GOBLIN FIREBALL COMBO

- *Batteries: 6S – 1000/1250mAh.
- *1 flybarless 3 axis control unit.
- *6 channel radio control system on 2.4 GHz.

TOOLS, LUBRICANTS, ADHESIVES

- *Generic pliers.
- *Hexagonal Screw Driver, size 1.5, 2, 2.5mm.
- *4.5, 5, 5.5mm Socket wrench.
- *Medium threadlocker (eg. HA116-S)
- *Strong retaining compound (eg. HA115-S)
- *Spray lubricant (eg. Try-Flow Oil)
- *Grease (eg. Microlube GL261)
- *Cyanoacrylate adhesive
- *Pitch Gauge (for set-up)
- *Soldering equipment (for motor wiring)

INSIDE THE BOX:

Main Box: Canopy, Landing Gear, Main Blades, Tail Blades, Boom, Box 1, Box 2, Carbon Rod, Blade Holder.

Box 1: Motor , Servos & ESC for SG281.

Box 2: Bags.

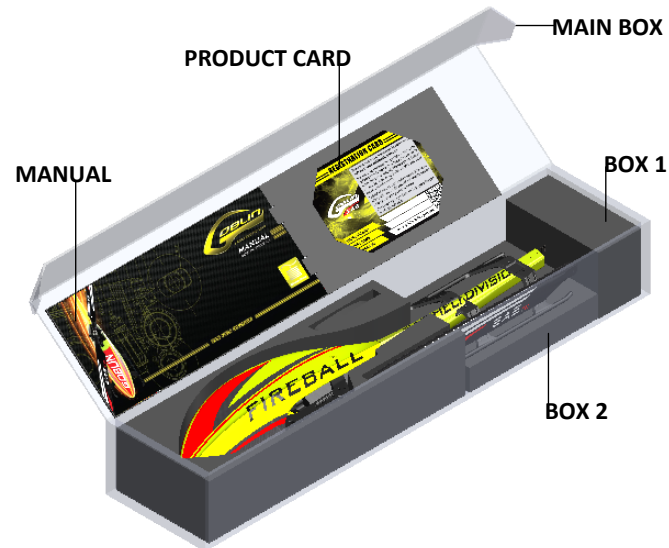

The assembly process is described in the following chapters. Each chapter provides you with the bag you will need for that chapter. The information is printed in RED color in the top corner of the page.

Tail Servo Assembly

Tail Servo is a Micro size (12x23mm)
(SAB DS12T: Frequency 760ms/560hz)
The distance between the axis and the ball must be between 9 - 10mm

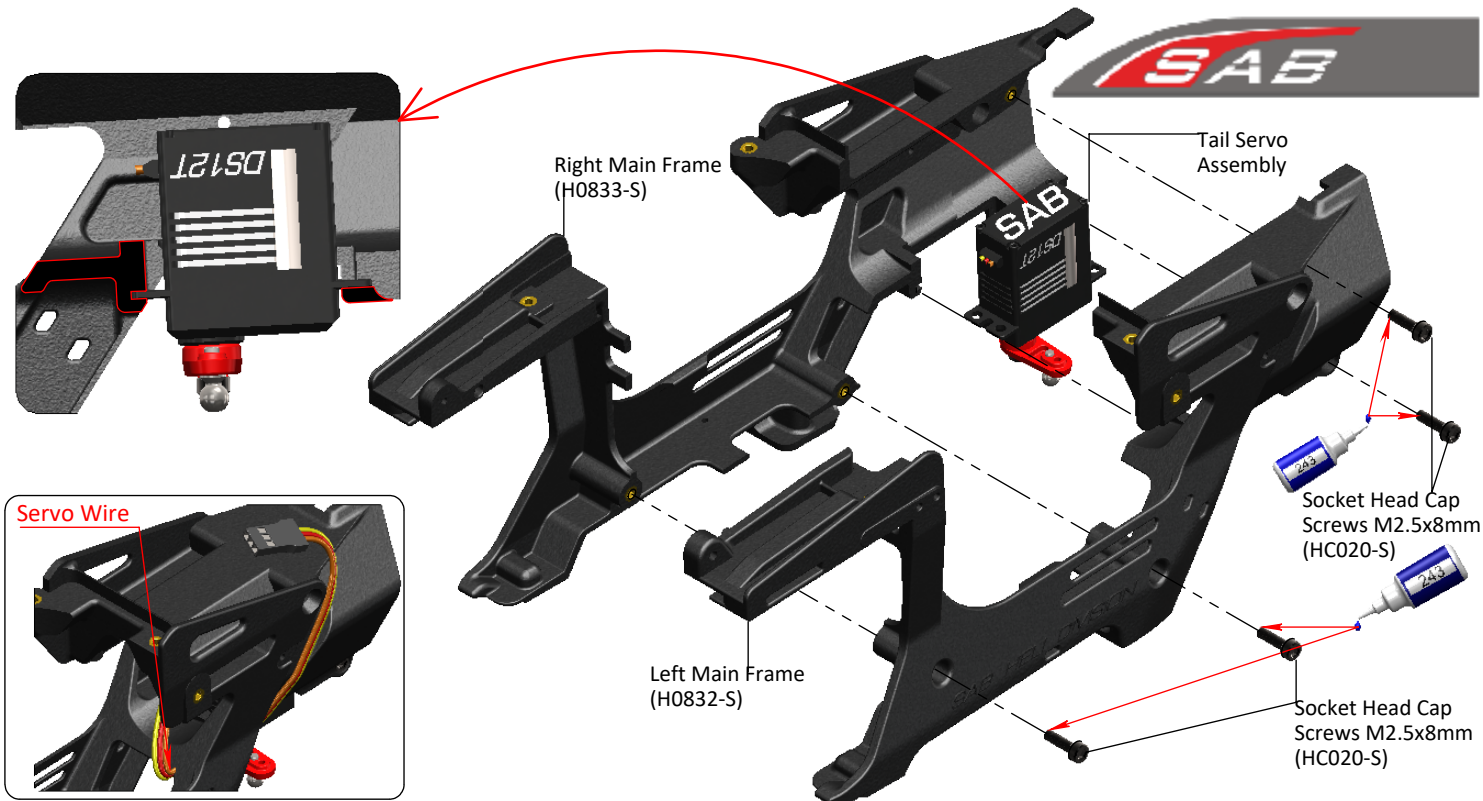
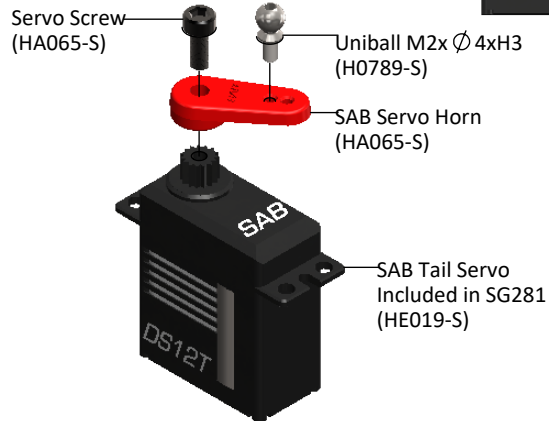
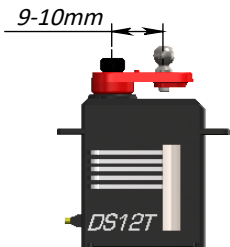

Note:
The tail servo is held in place by the tension created when the main frame is assembled; this means that there is no requirement to attach the servo directly with screws.
The tail servo can be removed by loosening the screw that tensions the frame to the tail boom. There is no requirement to disassemble the frame completely.
Page 5





Landing Gear Assembly

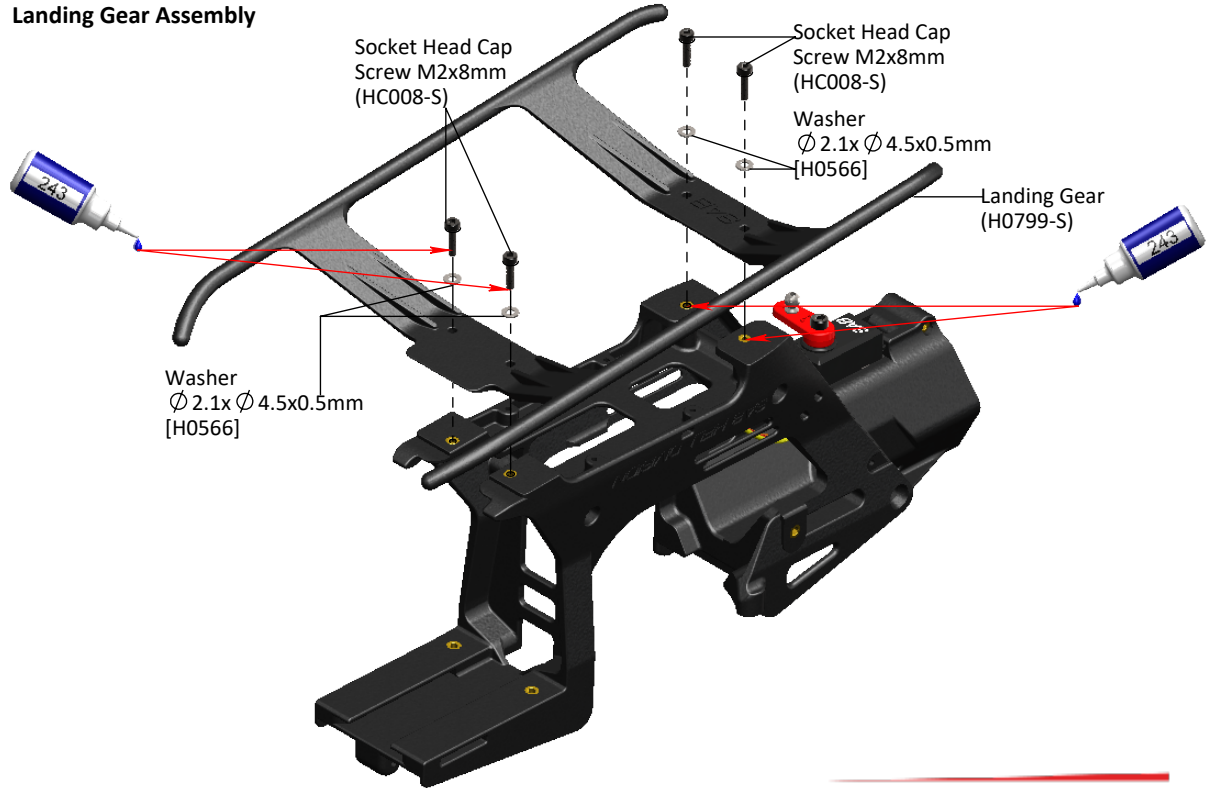

Tail Rotor Hub Assembly

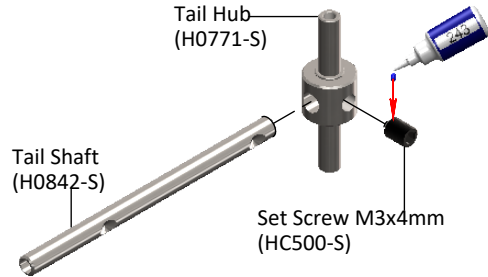

Tail Pitch Slider Assembly

Already Assembled

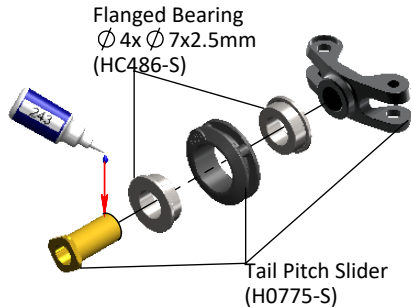

Tail Pitch Slider Link Assembly

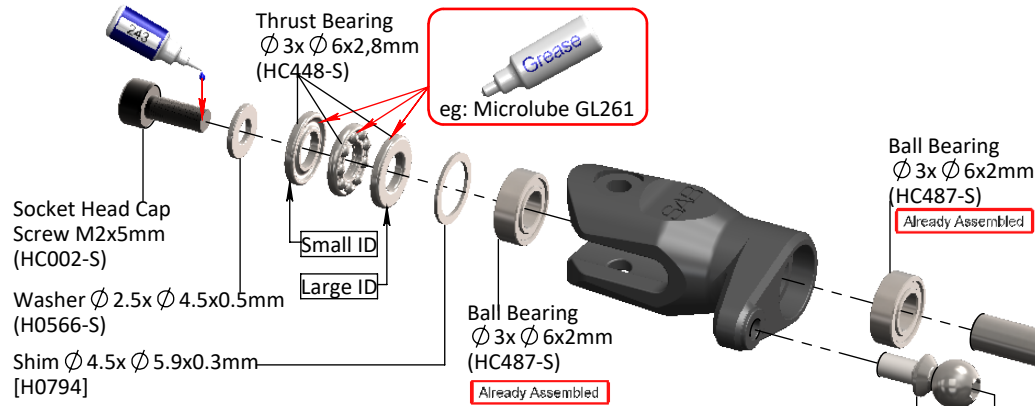
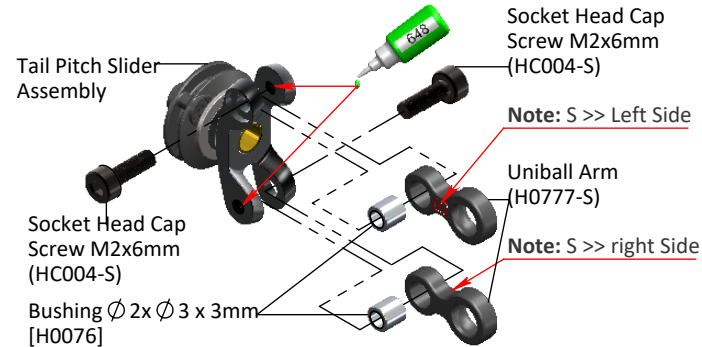

Note:
It is a normal for the tail to feel tight after initial assembly. After 2-5 flights, the tail system will loosen and feel much smoother.

Uniball M2x $\varnothing 4 \times \text{H3}$ (H0789-S)

Note: Do not over tighten, be careful to avoid stripping the plastic .

eg: Microlube GL261

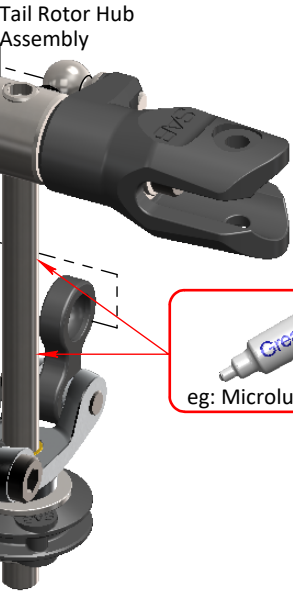



Tail Side Plate Assembly

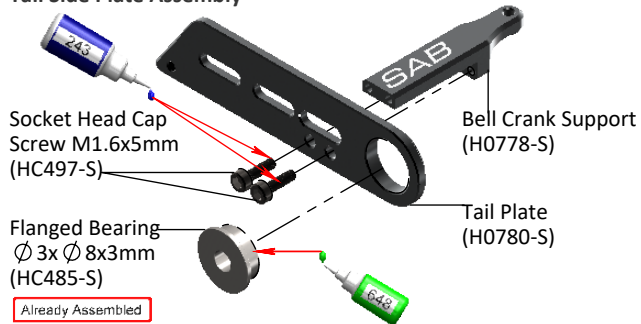

Bell Crank Lever Assembly

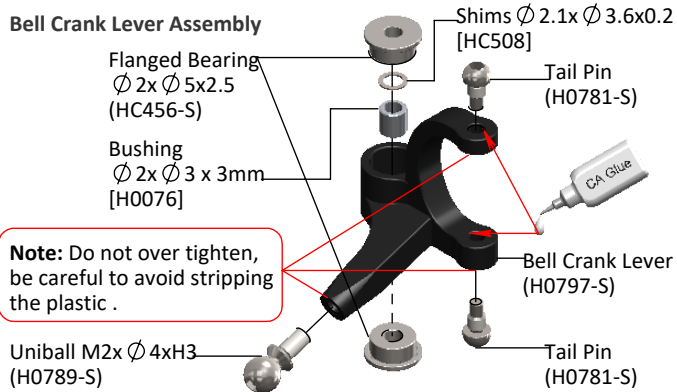

Tail System Assembly

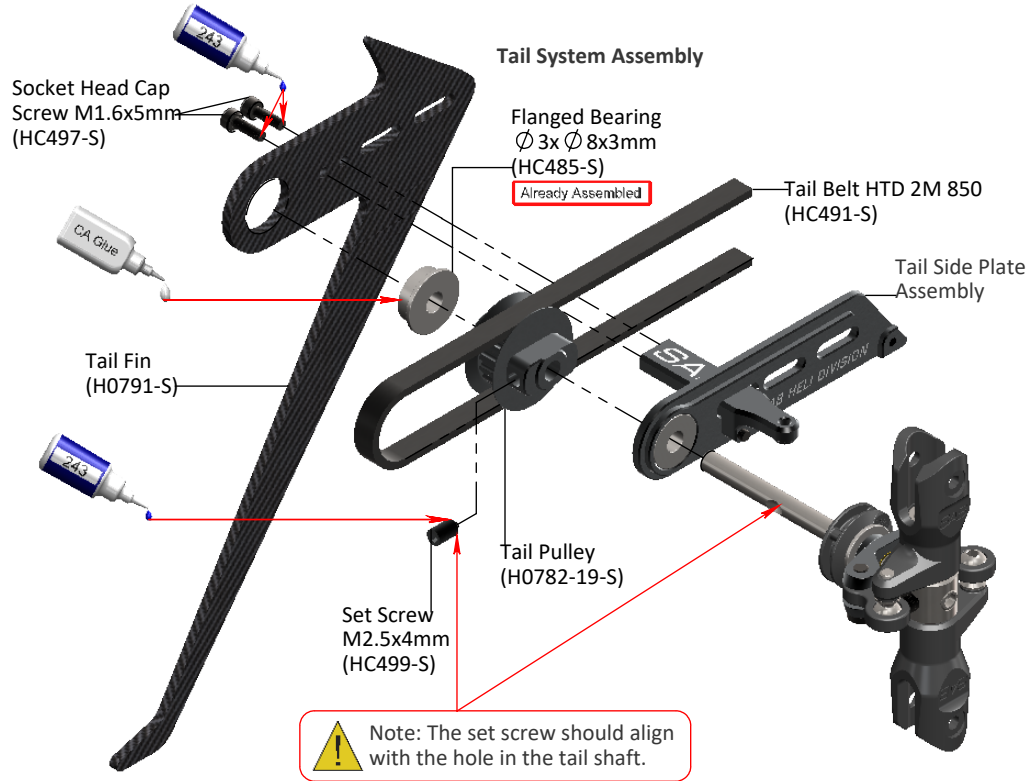

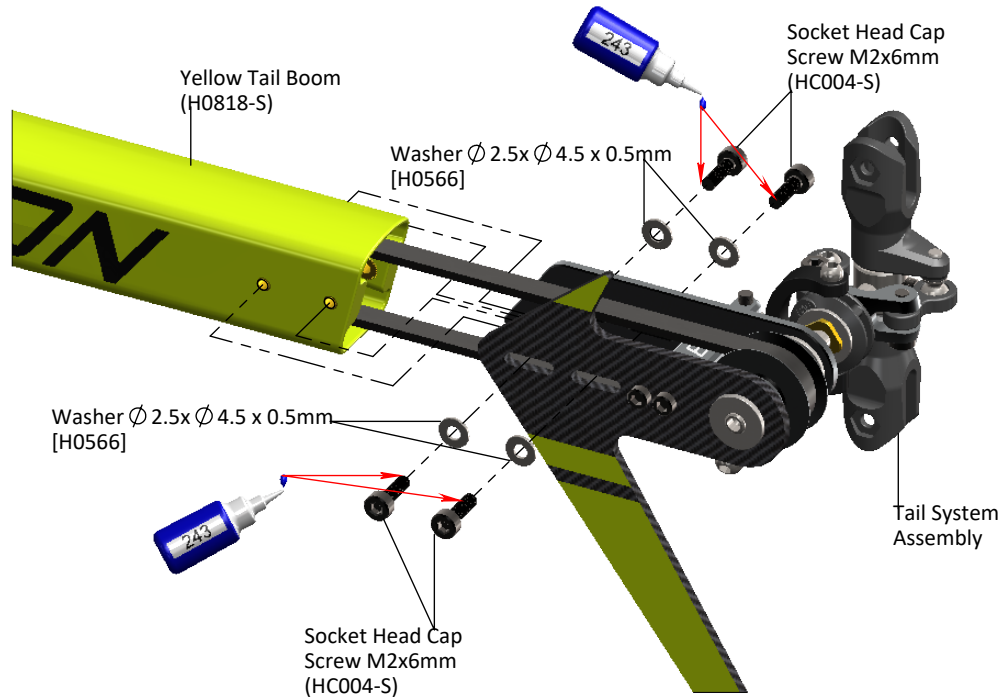

Note: Please allow plenty of time for the glue to cure before inserting the plastic ball link onto the threaded rod.

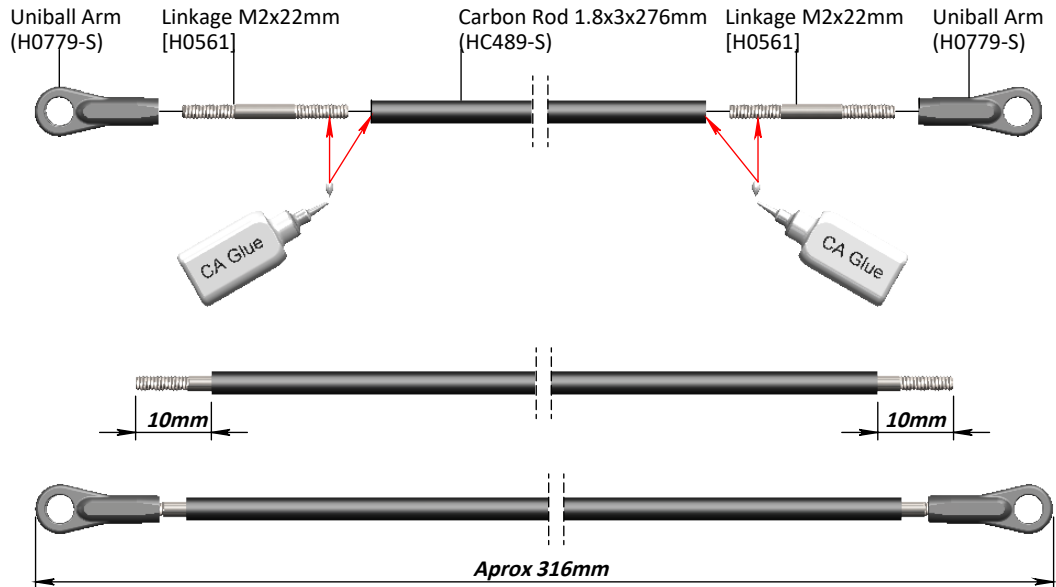

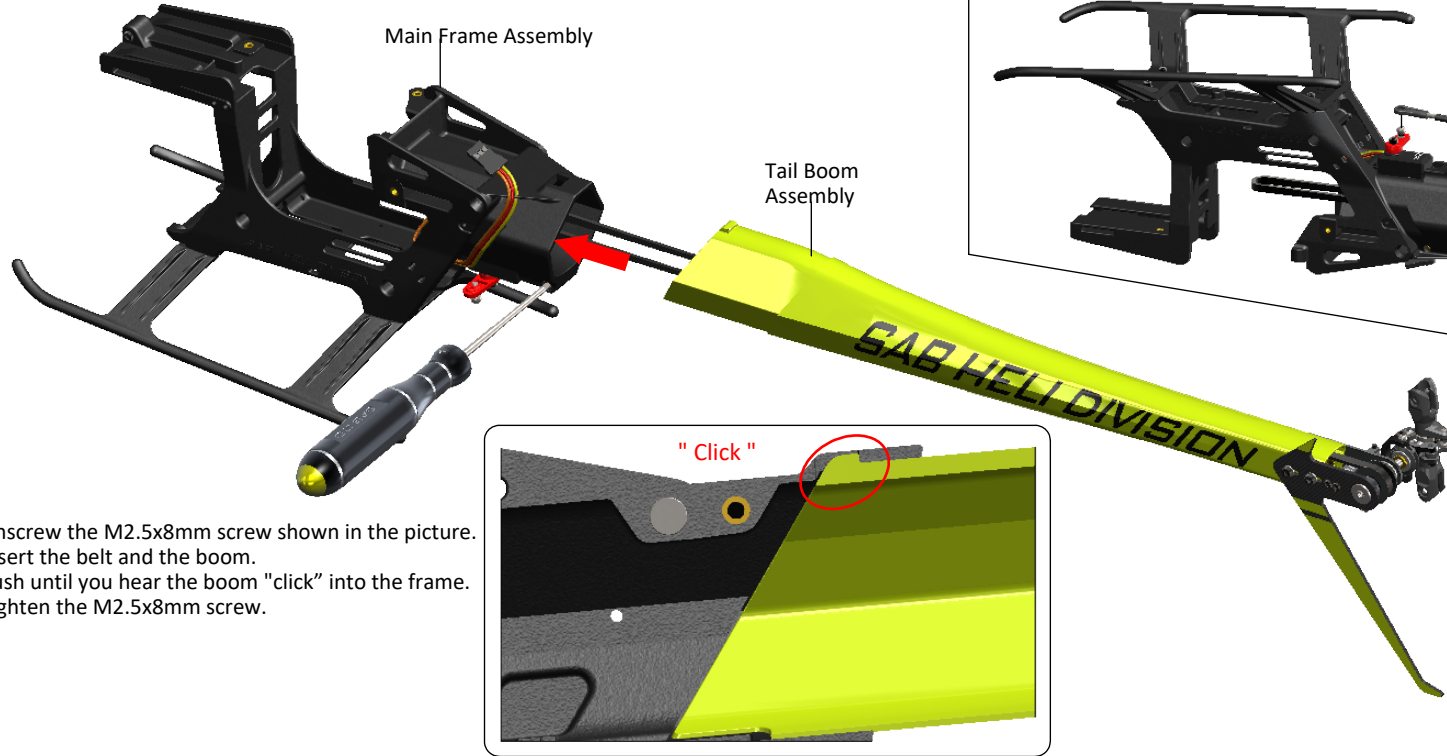

Unscrew the M2.5x8mm screw shown in the picture. Insert the belt and the boom. Push until you hear the boom "click" into the frame. Tighten the M2.5x8mm screw.

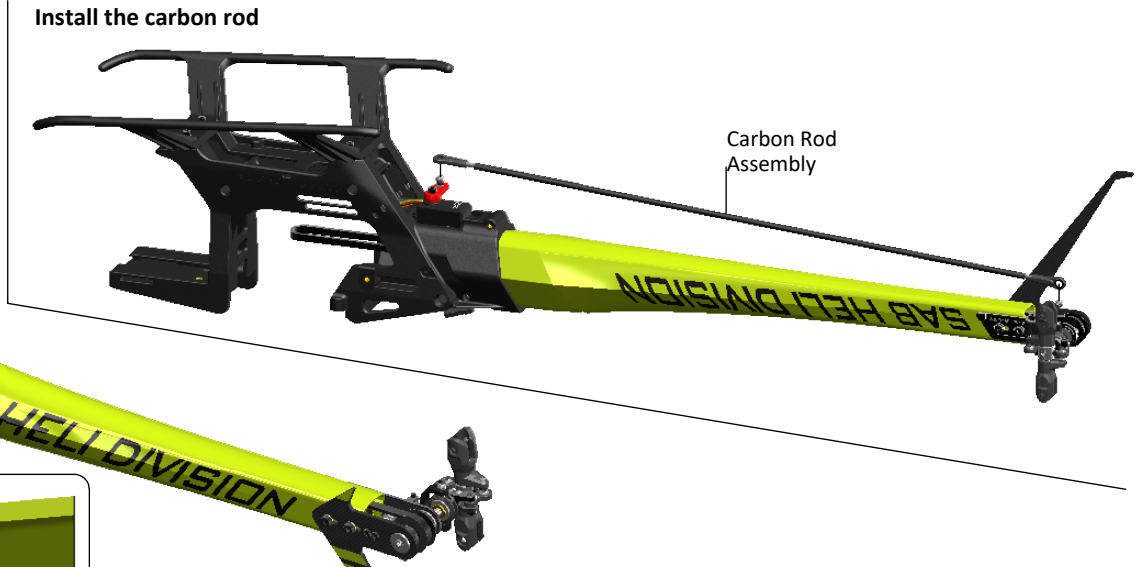

Motor Assembly

Before installing the motor, securely solder the connectors in place. (Connectors are included in the COMBO kit SG281).

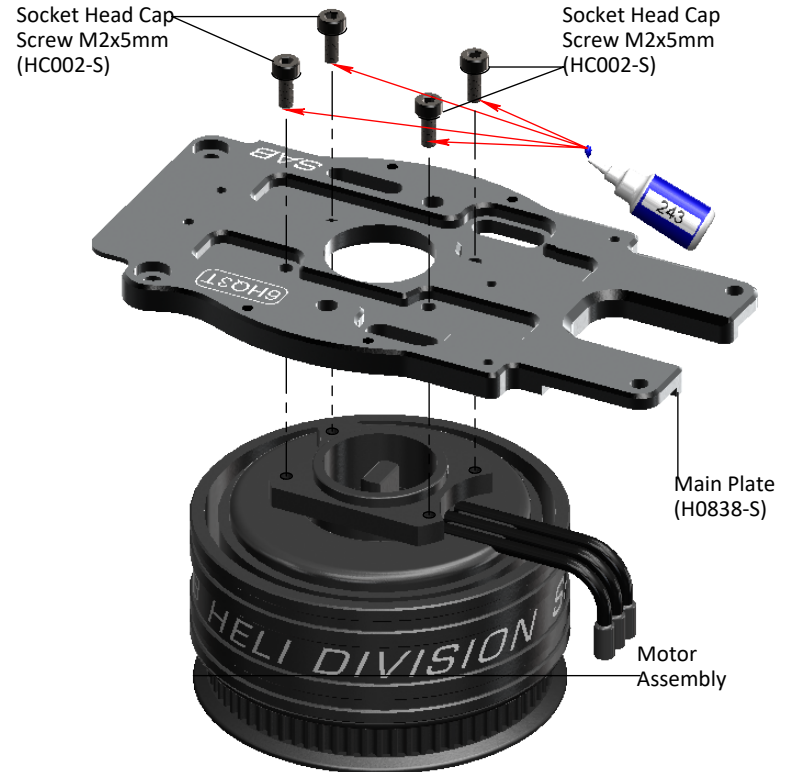
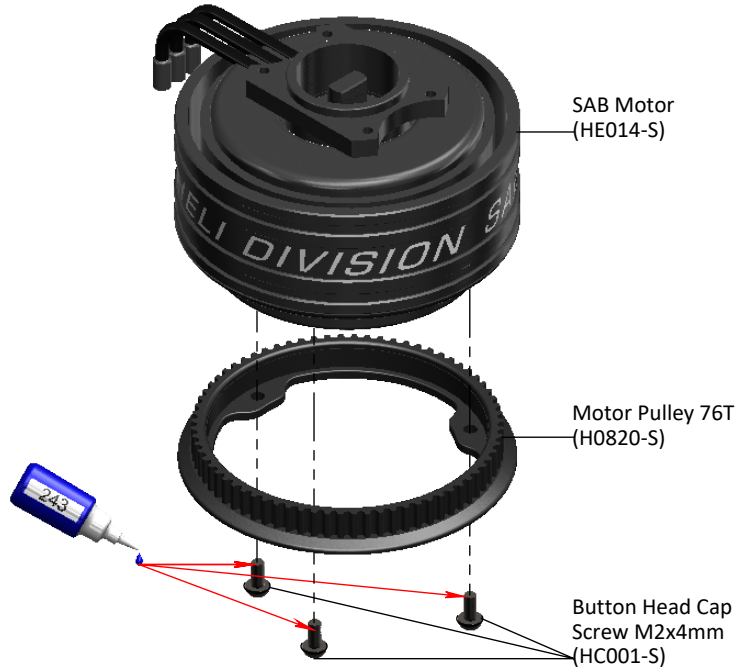



SAB ESC
(HE022-S)
Included in SG281

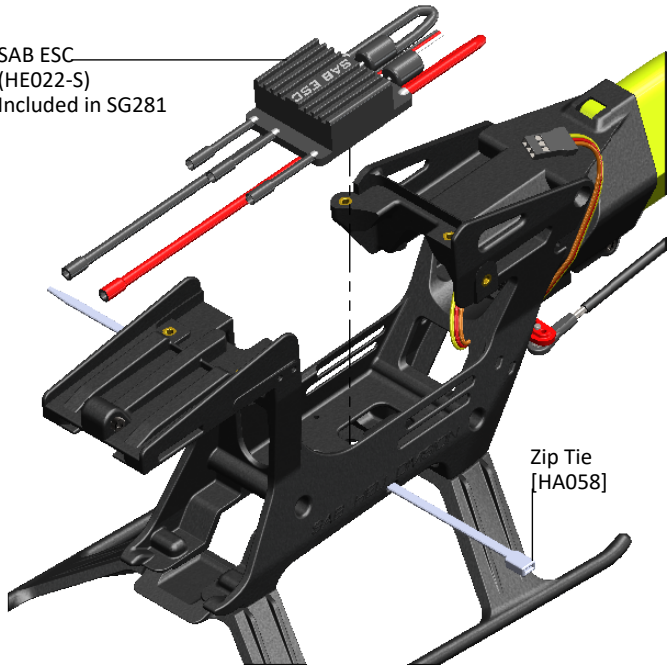

Zip Tie
[HA058]

Note: Make sure to secure the ESC in place with a zip tie.

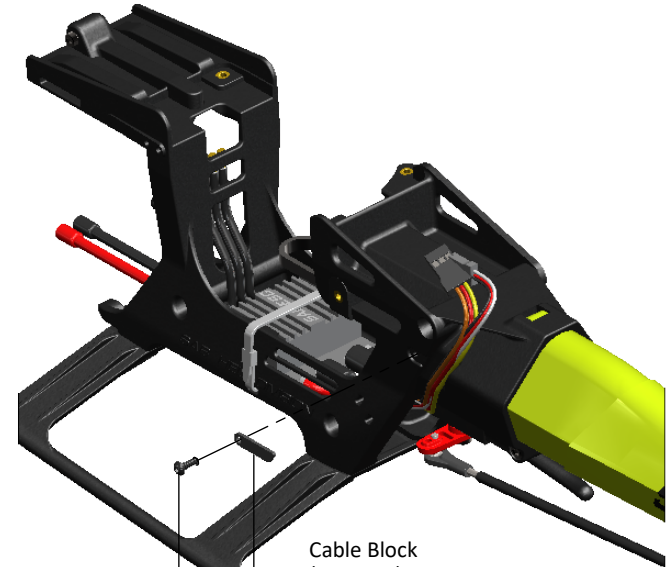
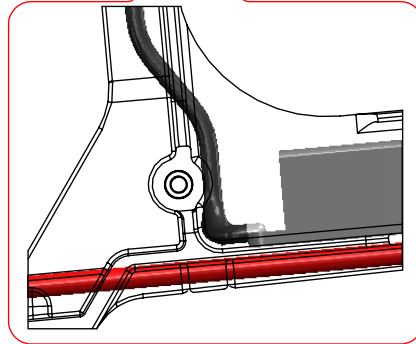
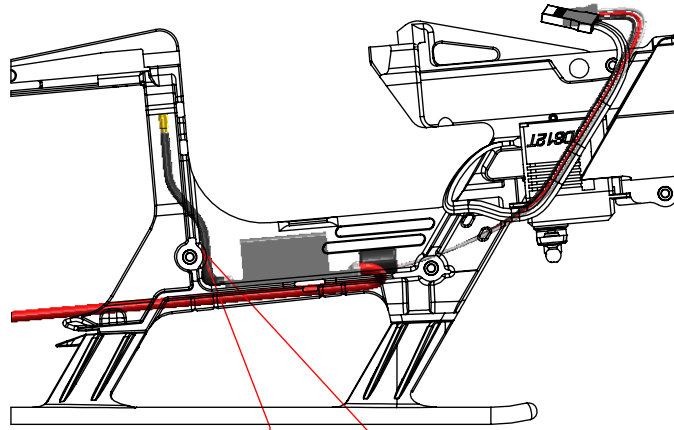

Cable Block
(H0858-S)

Socket Head Self
Tapping Screw M2.2x6mm
(HC490-S)

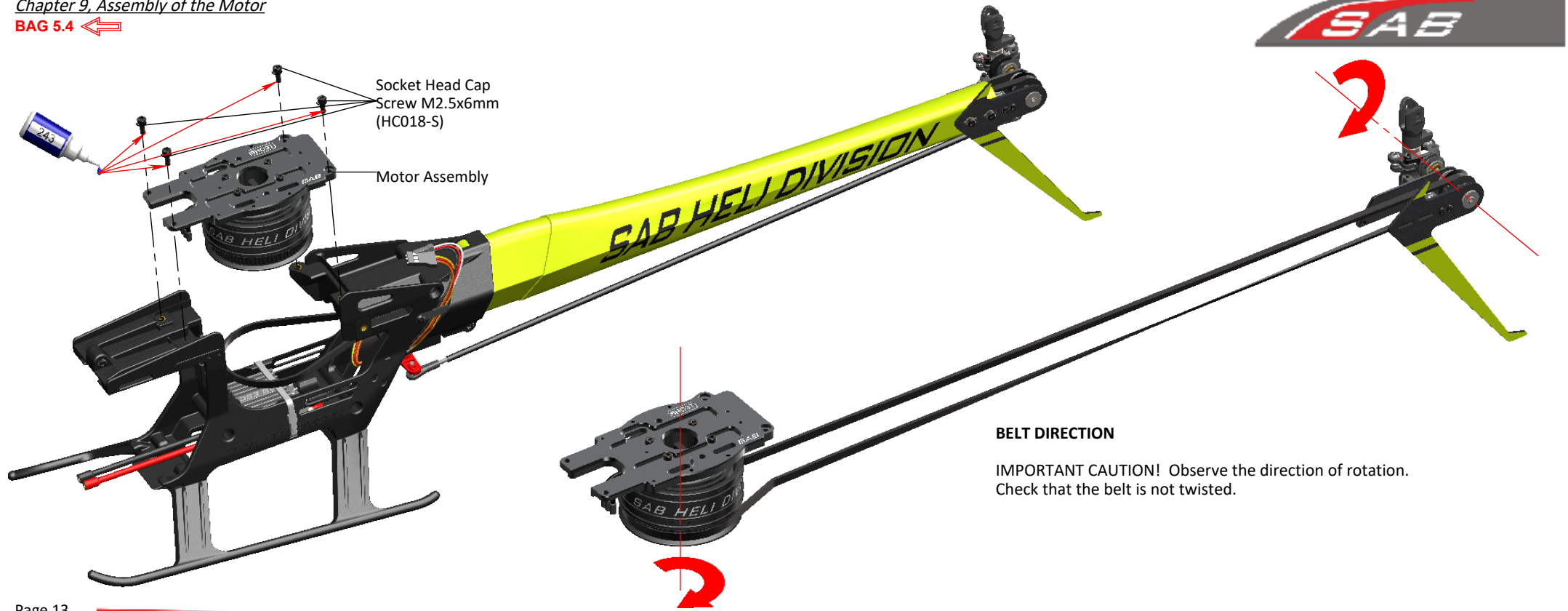

Socket Head Cap
Screw M2.5x6mm
(HC018-S)

Motor Assembly

BELT DIRECTION

IMPORTANT CAUTION! Observe the direction of rotation.
Check that the belt is not twisted.



Left Tail Belt Tensioner Assembly (H0870-S)

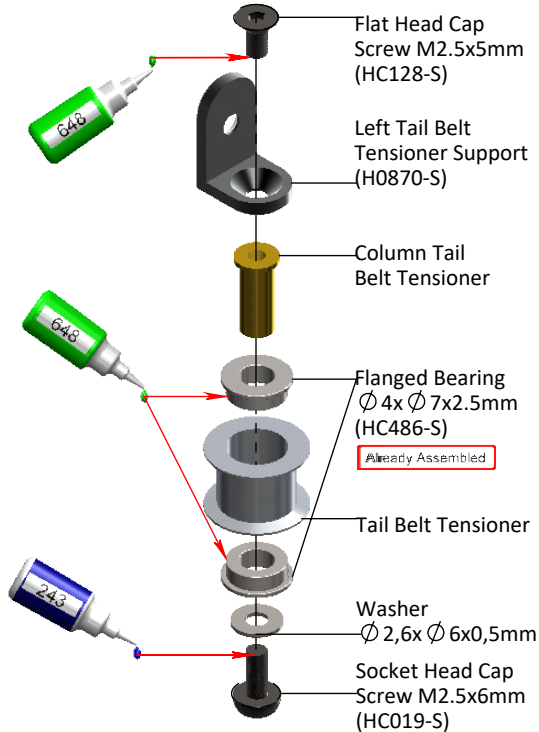

Right Tail Belt Tensioner Assembly (H0899-S)

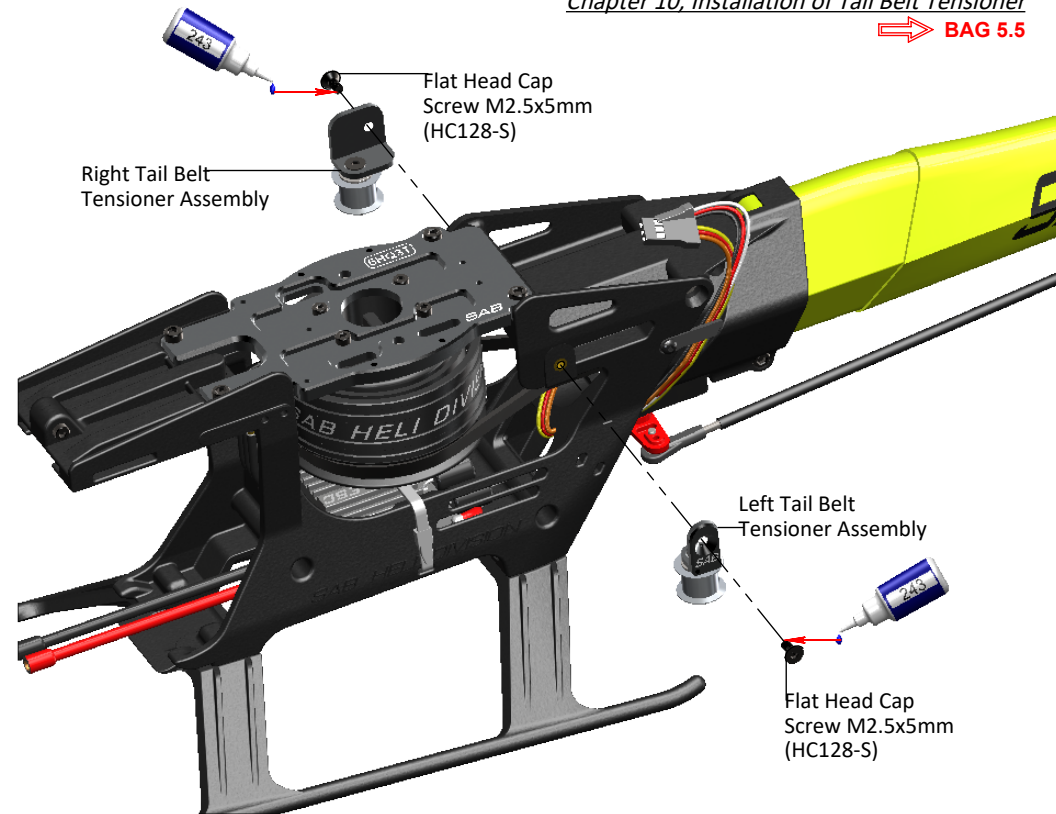
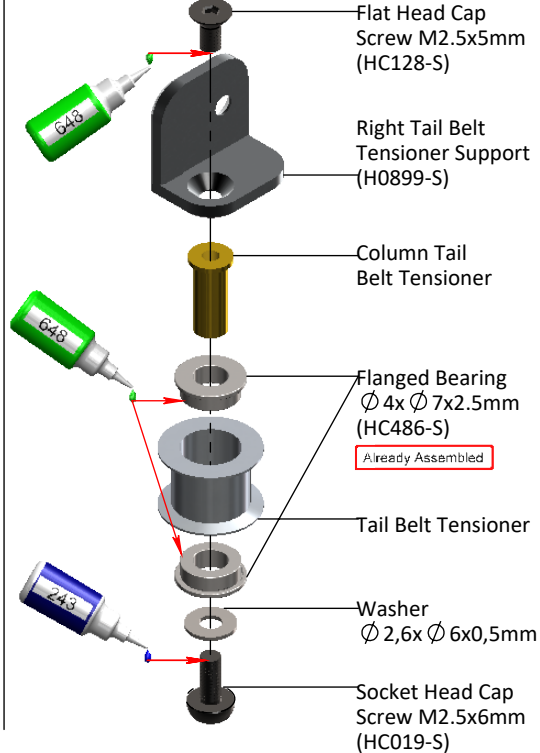



INSTALLATION OF SWASHPLATE SERVOS

The Cyclic servos are micro size. (SAB DS12C: Frequency 1520ms/333hz)
The linkage ball must be positioned between **9/10 mm** out on the servo arm (**Figure 1**).
It is advisable to ensure alignment of the servo arms (and sub trim set) before installation of the servos in the model.
Proceed with installation following the instructions below.

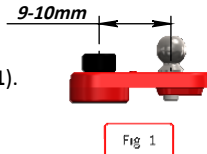

SERVO ASSEMBLY 1, 2, 3

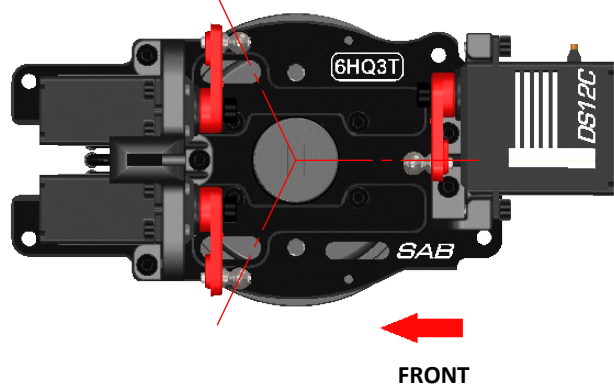
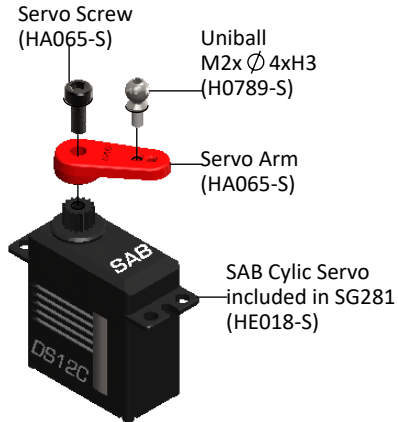

SERVO SUPPORT ASSEMBLY

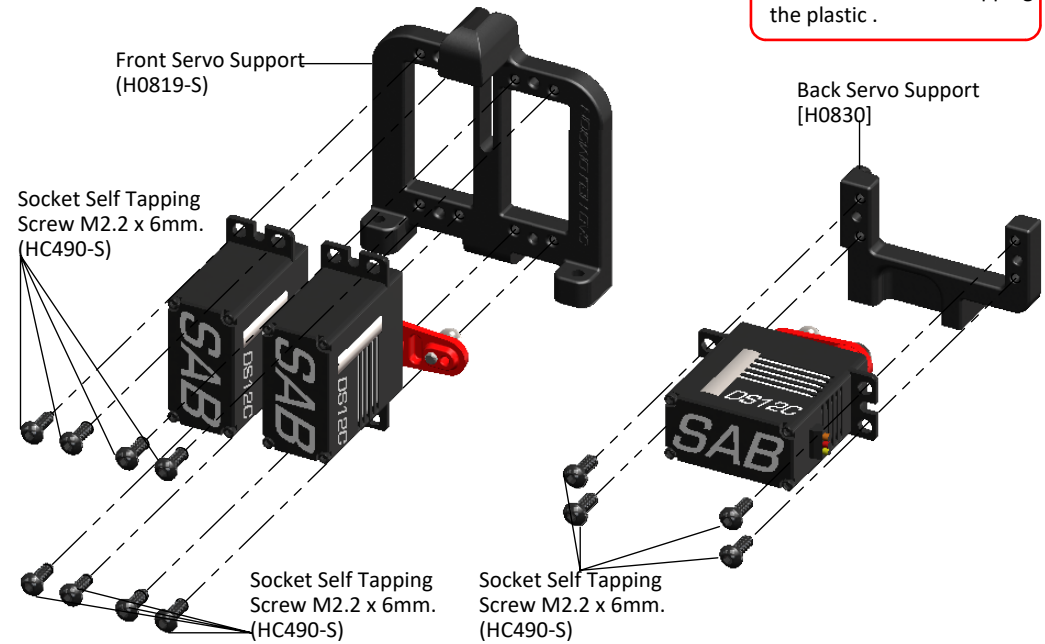

Note: Do not over tighten, be careful to avoid stripping the plastic.

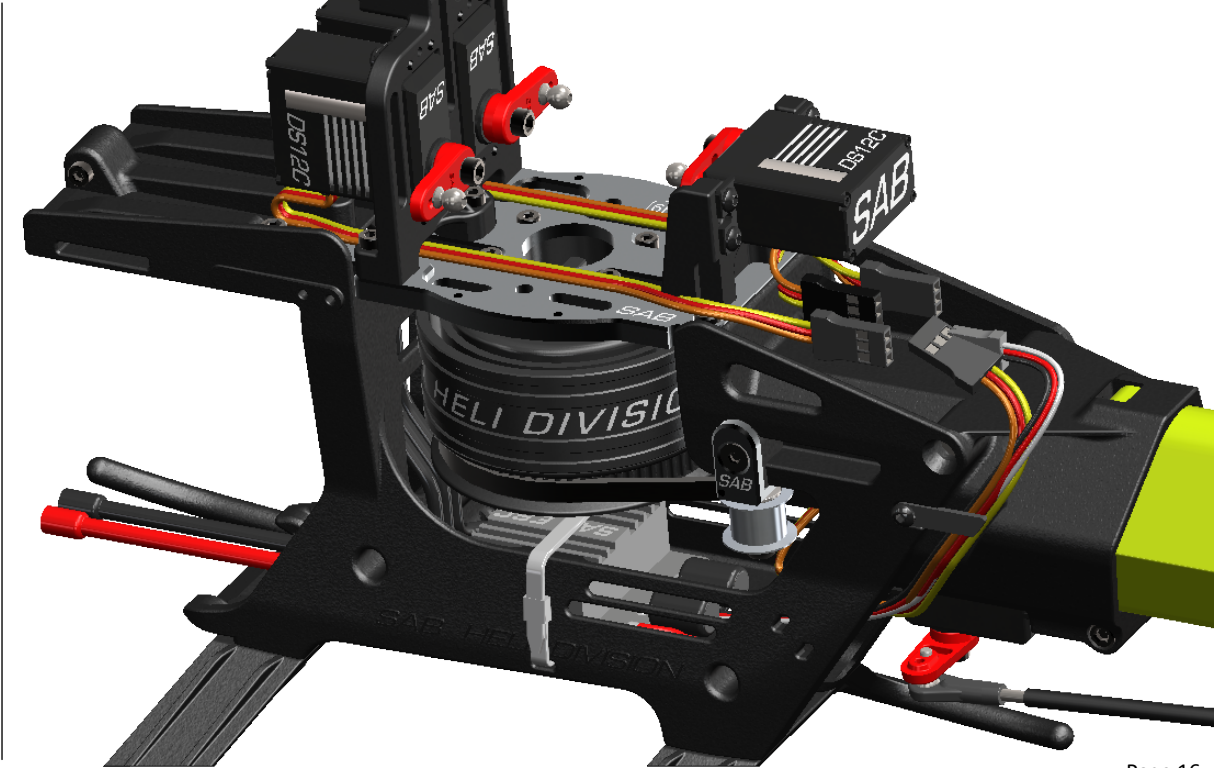
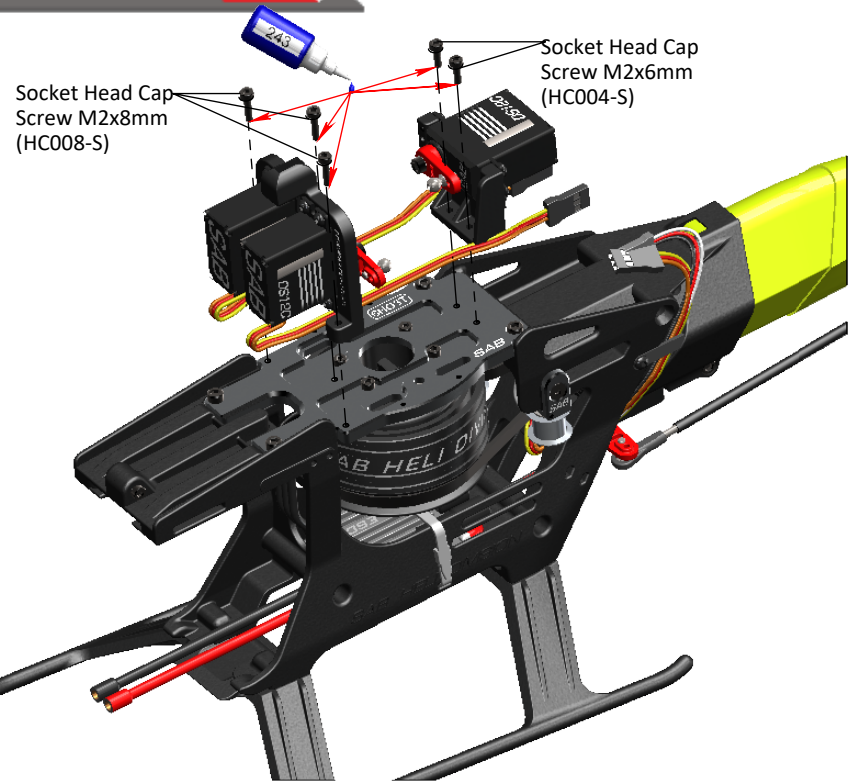



Blade Arm Assembly (H0795-S)

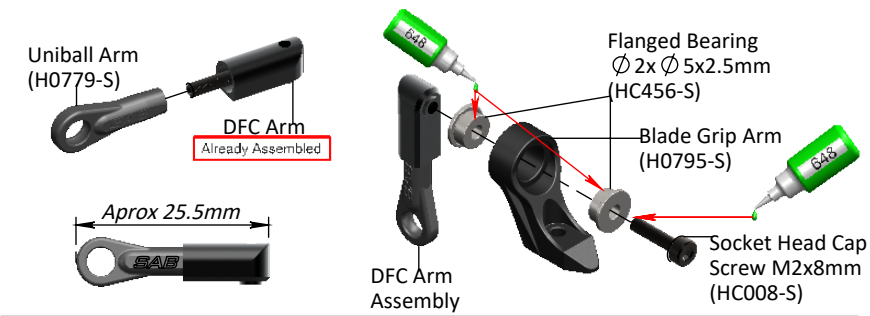

Blade Grip Assembly

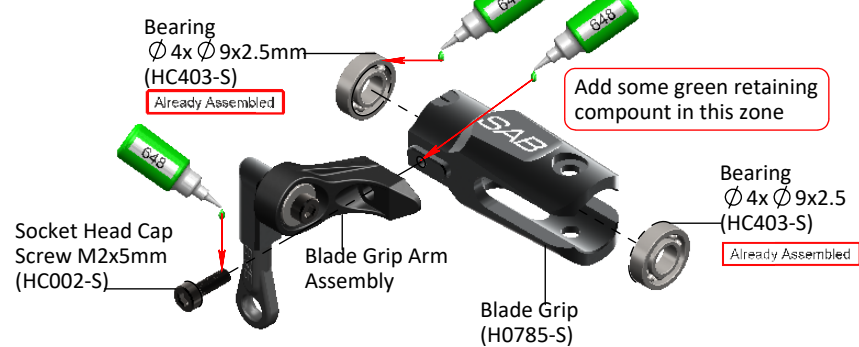

Main Rotor Assembly

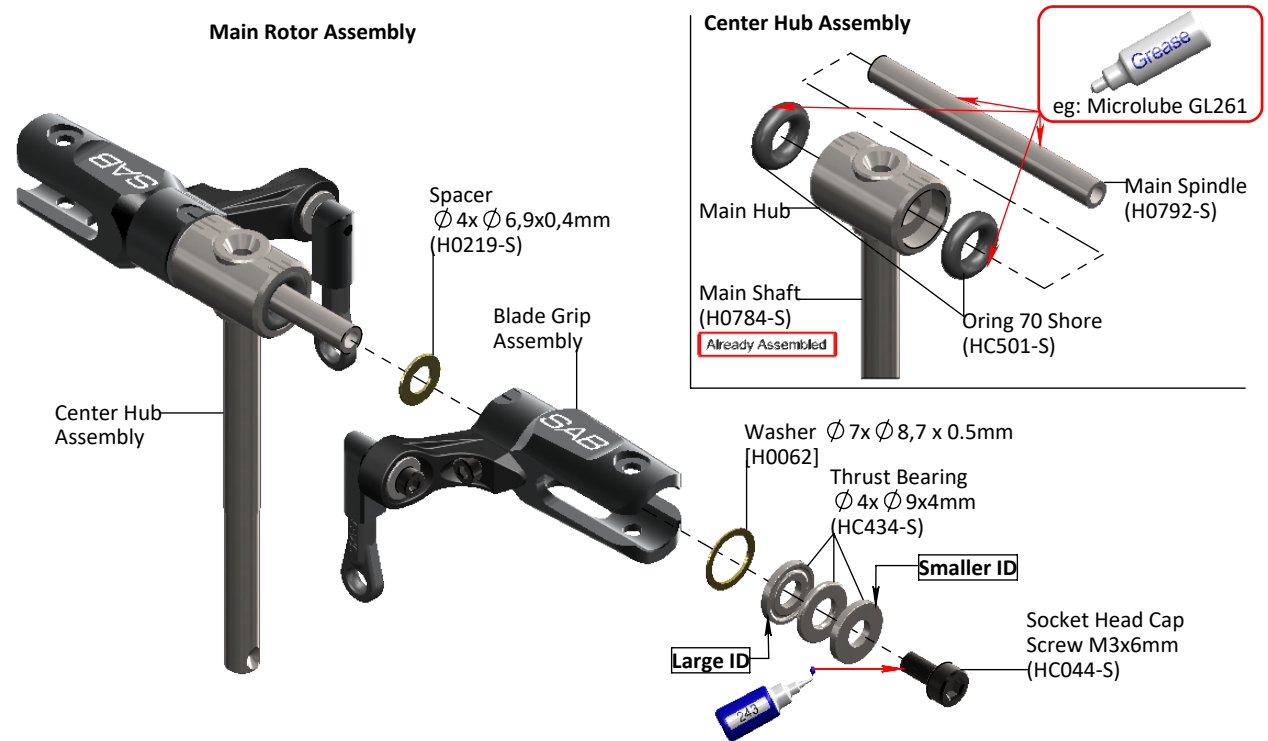

Bearing Support Assembly

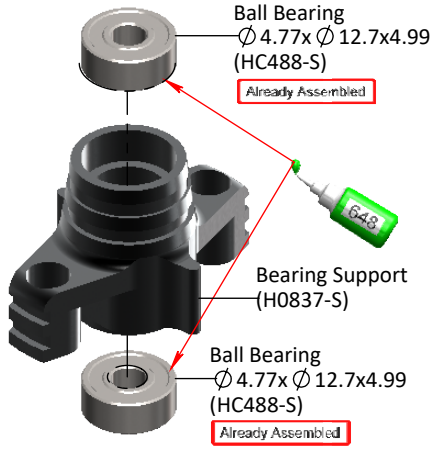

Swashplate Assembly

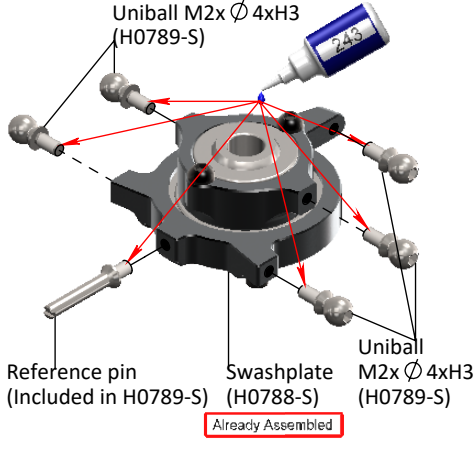

Start by adding 3 shims to remove any Axial main shaft play. Check that all play has been removed, if required add or remove shims. Shim $\varnothing 5 \times \varnothing 7 \times 0.1 \text{mm}$ (HC450-S)

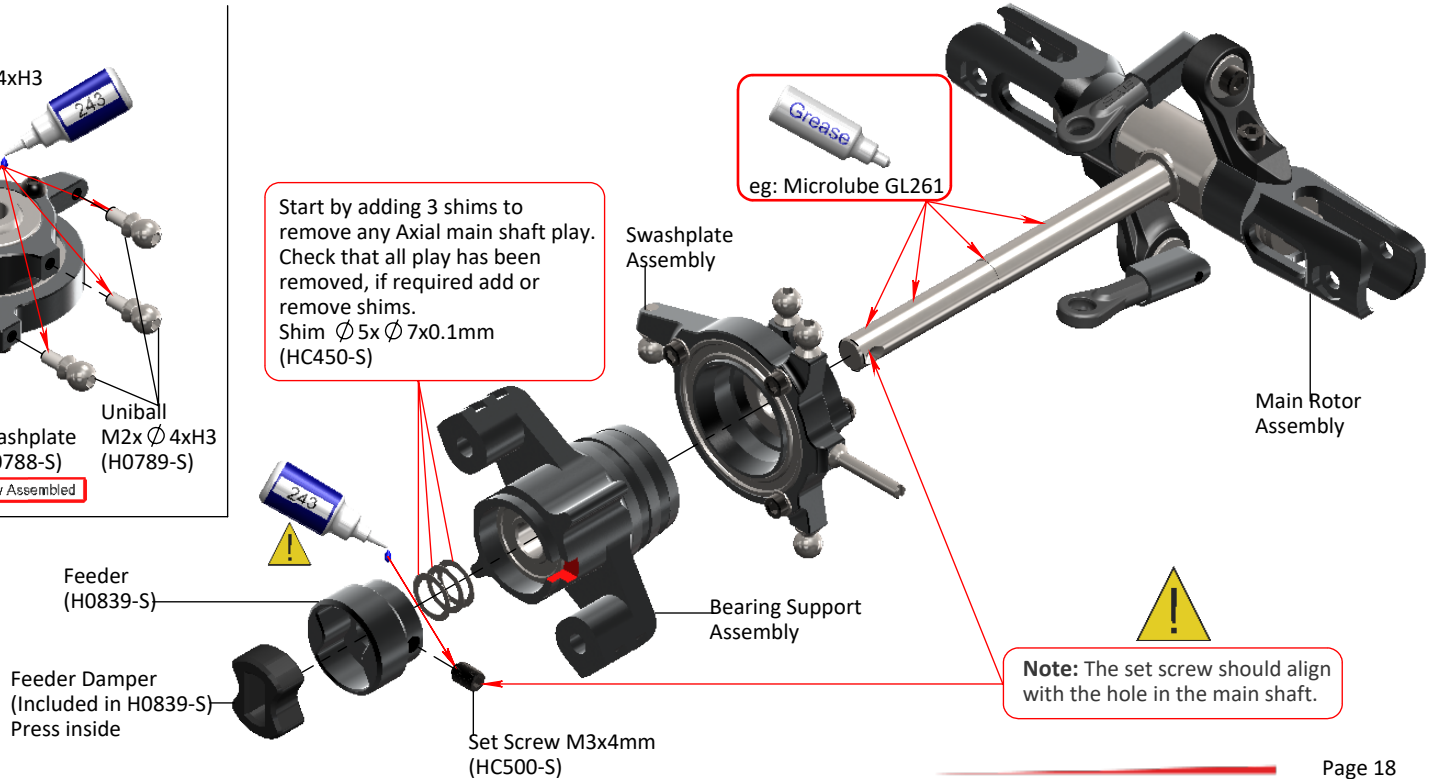

Socket Head Cap
Screw M3x10mm
(HC056-S)

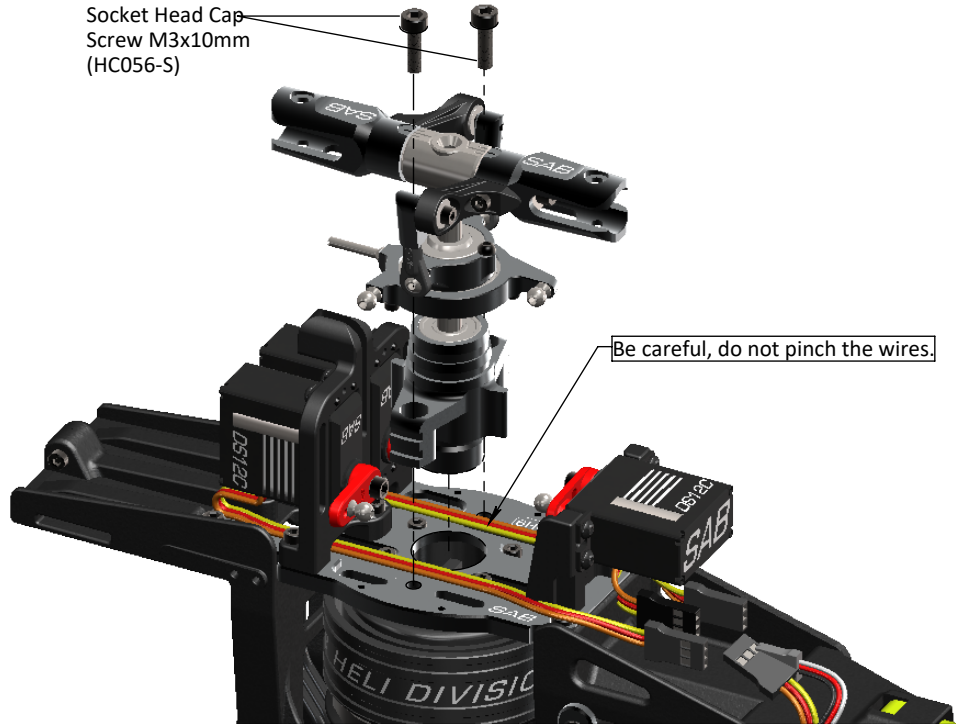

Note:
It is possible to
insert the linkage
using both sides.

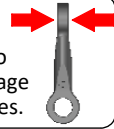

Servo Linkage
(H0796-S)

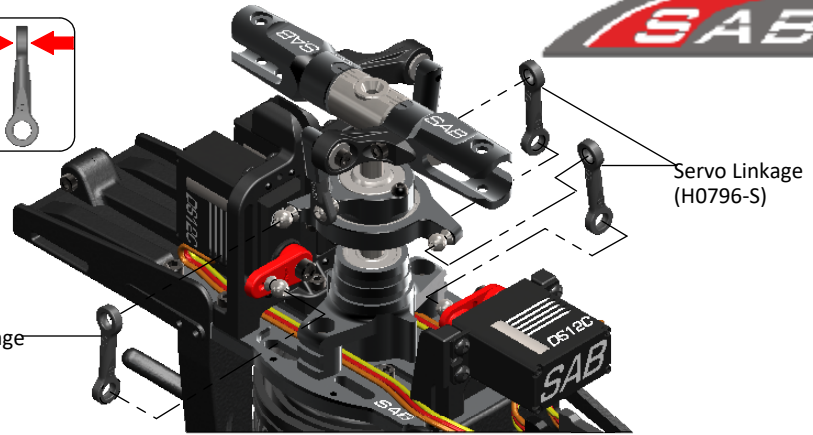

Servo Linkage
(H0796-S)

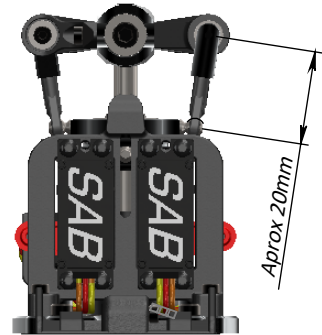
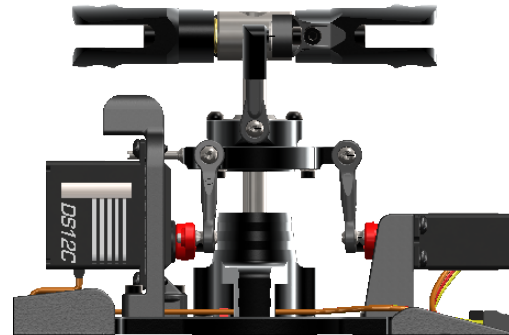



We suggest the use of a “mini” FBL system. This allows for easier wire routing considering the small size of this helicopter. Position 1 can be used to install the FBL unit. We recommend using some type of adhesive to ensure that the plugged connections to the receiver and FBL unit are secure. You can with care use a hot glue gun for this purpose.

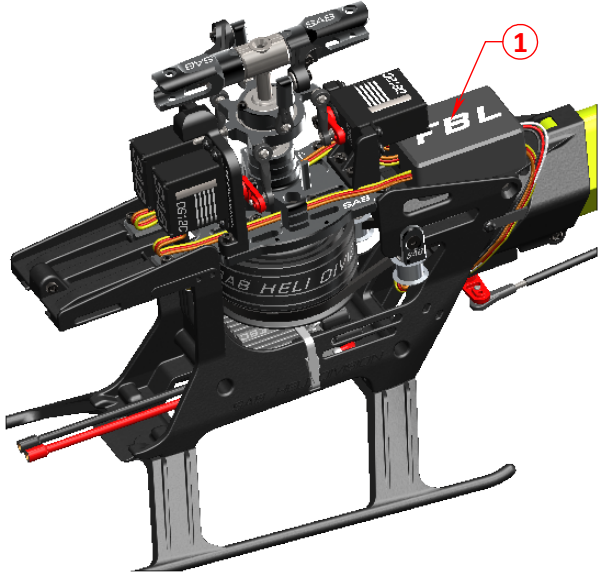

SAB HELI DIVISION

Position 2 or 3 can be used to install your RX unit. In accordance with your RX dimension H0900 can be used as support. Figure 1 and 2 show some example of installation.

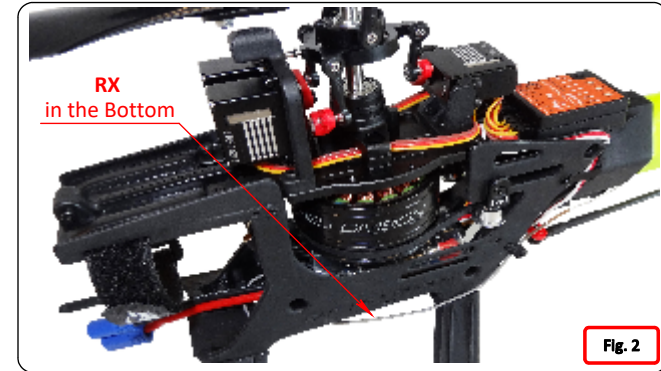
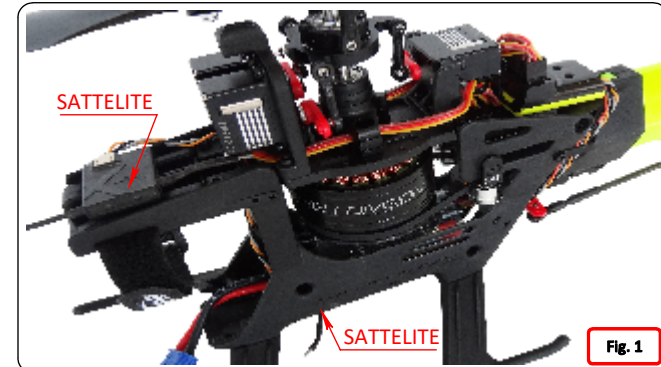
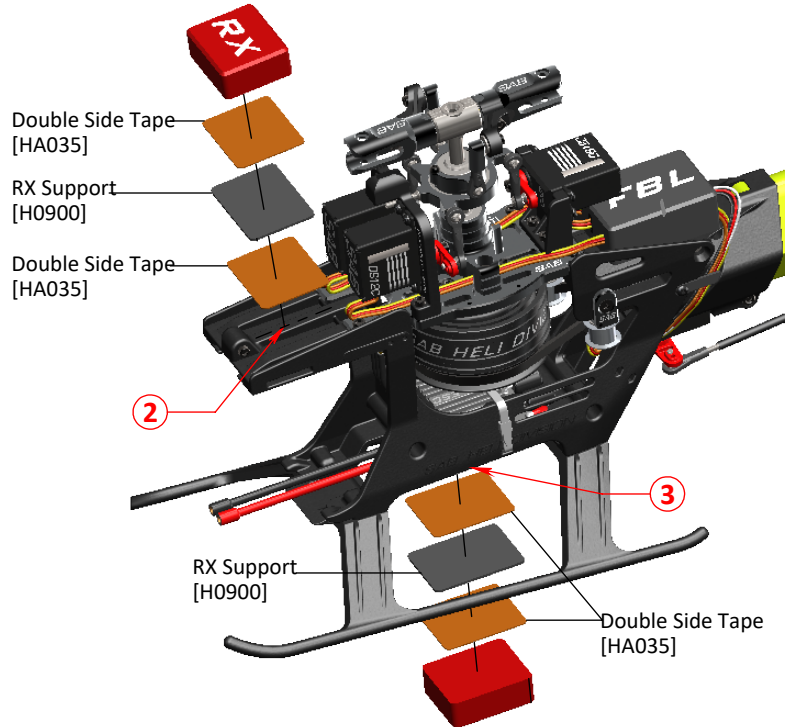

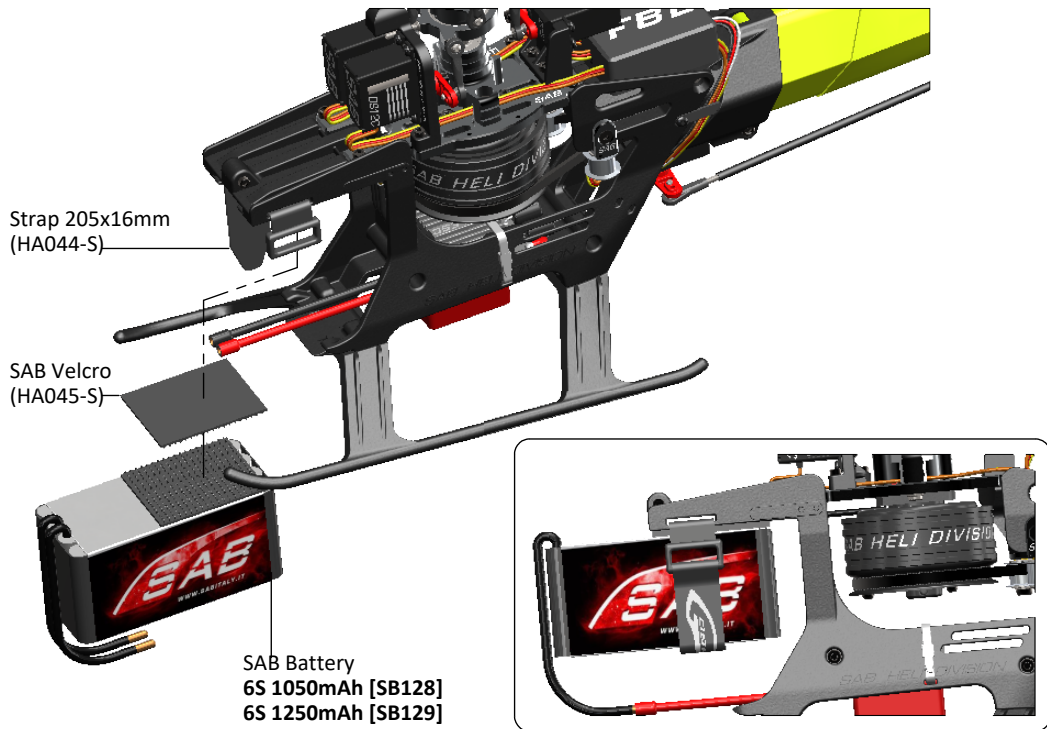

CANOPY

Tighten the 2 screws with little torque.
Use green loctite and lean slightly without pressure.

Using sandpaper, You need to remove the edges on the connection zone between the canopy and the frames. Follow the pictures.

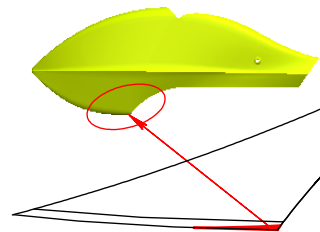

Push firmly the canopy to the frames to get the correct locking position.

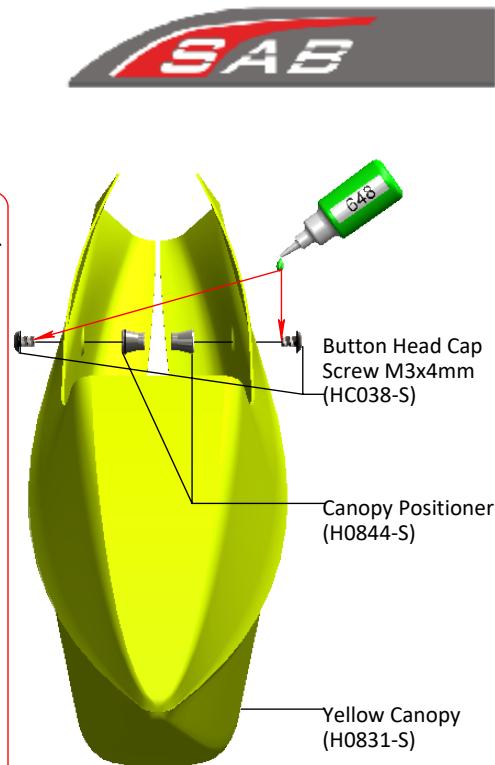
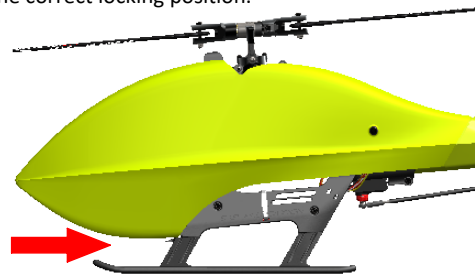



For correct sticker positions refer to the examples below.

Red / Yellow sticker set p/n (HA064-S).





OPERATIONS BEFORE FLIGHT

- * Check all wiring. Connectors must to be securely in position.
- * Set up the transmitter and the flybarless system with utmost care.
- * It is advisable to test the correct settings of the transmitter and flybarless system without main blades and tail blades fitted.
- * Set up the RPM of the main rotor. Please check follow table:

ESC Set Up				
<i>SAB ESC throttle (gov. mode)</i>		60%	75%	85%
Standard Motor (HE014)	rpm	3000	3800	4200
Competition Motor (HE015 Upgrade)	rpm	3500	4500	5000

- *Set up the Main Rotor and Tail Rotor gain.

Reference Gain Value			
<i>Main rotor rpm</i>	<i>3500rpm</i>	<i>4000rpm</i>	<i>4500rpm</i>
Head	60	55	50
Tail	50	45	40

- *Fit the main blades and tail blades. (Fig.1 and Fig.2)
(Important, remove the 2 small protection transparent stickers attached on the main blades).

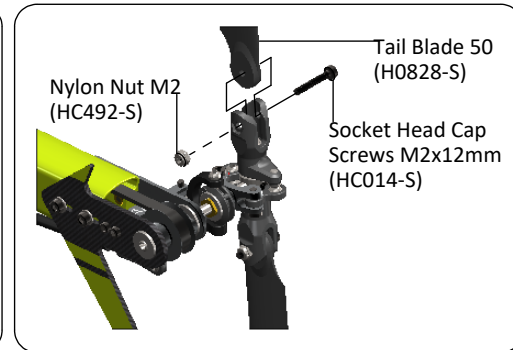
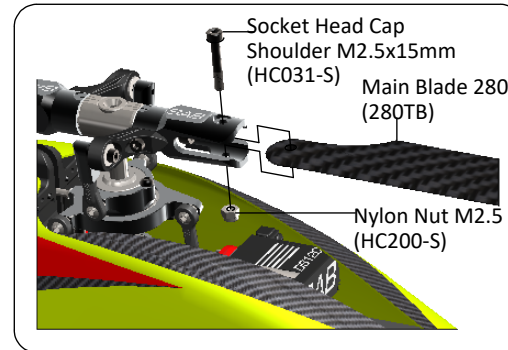

- *Check the collective and cyclic pitch. For 3D flight, set about +/- 13°.
- *It is important to check the correct tracking of the main blades.
- *Perform the first flight at a low head speed, (3000 rpm)
After this first flight, do a general check of the helicopter. Verify that all screws and bolts are correctly tightened. Tighten if necessary.

IN FLIGHT

It is very important to check the model thoroughly after the first 2-3 flights. Check all bolts, screws, belts, ball links, etc.
If the model is making strange noises, this can be usually attributed to incorrect belt tensions. Check the belts again and tighten if necessary.

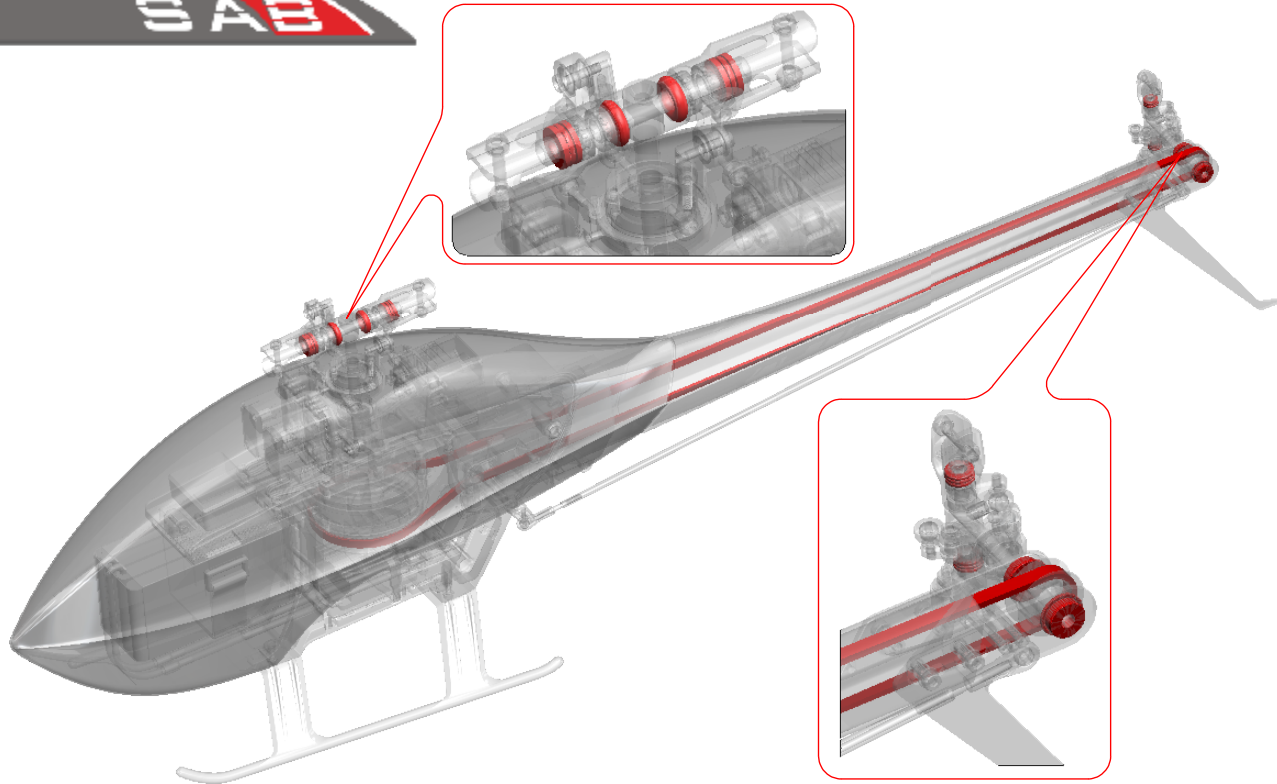

* On the Goblin Fireball, some areas to look for wear include:

- Tail belt
- O-Ring Dampers

* The most stressed bearings are definitely those on the tail shaft and the thrust bearings. Check them frequently. All other parts are not particularly subject to wear.









* The lifespan of these components varies according to the type of flying. On average it is recommended to check these parts every 20 flights. In some instances, based on wear, these parts should be replaced every 100 flights.

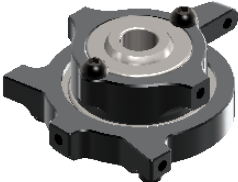







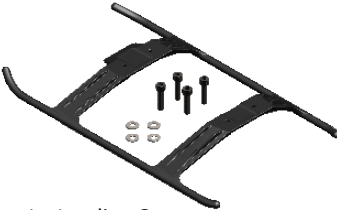
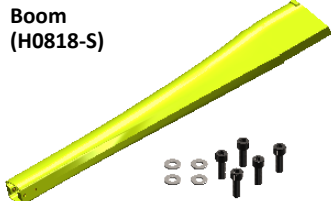

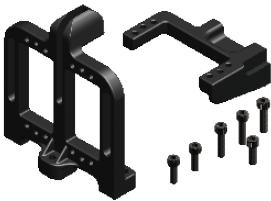

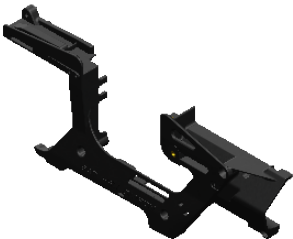
* Periodically lubricate the tail slider movement and its linkages as well as the swashplate movement and its linkages.



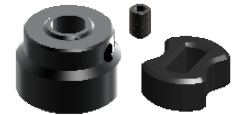
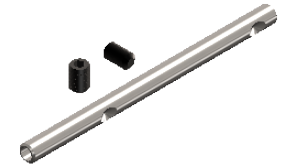







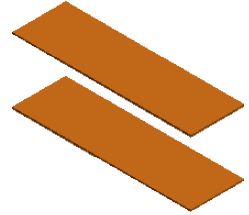
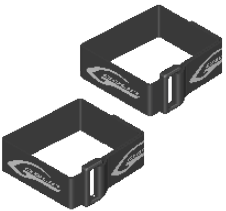
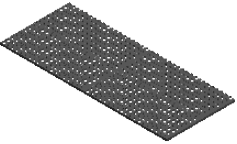

* To ensure safety you should do a general inspection of the helicopter after each flight. You should check:















- Proper belt tension
- All screws and bolts remain tight.









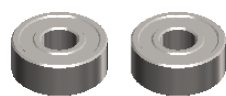









<p>Washer $\varnothing 7 \times \varnothing 8,7 \times 0,5\text{mm}$ (H0062-S)</p>  <p>- 4 x Washer $\varnothing 7 \times \varnothing 8,7 \times 0,5\text{mm}$.</p>	<p>Spacer $\varnothing 4 \times \varnothing 6,9 \times 0,4\text{mm}$ (H0219-S)</p>  <p>- 2 x Spacer $\varnothing 4 \times \varnothing 6,9 \times 0,4\text{mm}$.</p>	<p>Washer $\varnothing 2,5 \times \varnothing 4,5 \times 0,5\text{mm}$ (H0566-S)</p>  <p>- 10 x Washer $\varnothing 2,5 \times \varnothing 4,5 \times 0,5\text{mm}$.</p>	<p>Tail Hub (H0771-S)</p>  <p>- 1 x Tail Hub. - 2 x Washer $\varnothing 2,5 \times \varnothing 4,5 \times 0,5\text{mm}$. - 2 x Socket Head Screw M2x5mm. - 1 x Set Screw M3x4mm.</p>	<p>Tail Pitch Slider (H0775-S)</p>  <p>- 1 x Tail Pitch Slider Assembled.</p>	<p>Tail Arm (H0777-S)</p>  <p>- 2 x Tail Arm. - 2 x Bushing $\varnothing 2 \times \varnothing 3 \times 3\text{mm}$.</p>
<p>Bell Crank Support (H0778-S)</p>  <p>- 1 x Bell Crank Support. - 4 x Socket Head Cap M1.6x5mm.</p>	<p>Plastic Ball Link (H0779-S)</p>  <p>- 5 x Uniball Arm.</p>	<p>Tail Side Plate (H0780-S)</p>  <p>- 1 x Tail Plate. - 1 x Flanged Bearing $\varnothing 3 \times \varnothing 8 \times 3\text{mm}$.</p>	<p>Tail Pin (H0781-S)</p>  <p>- 2 x Tail Pin.</p>	<p>Tail Pulley 19T (H0782-19-S)</p>  <p>- 1 x Tail Pulley 19T Assembled. - 1 x Set Screw M2.5x4mm.</p>	<p>Main Shaft (H0784-S)</p>  <p>- 1 x Main Shaft. - 1 x Main Hub.</p>

<p>Main Blade Grip (H0785-S)</p>  <ul style="list-style-type: none"> - 1 x Main Blade Grip. - 1 x Ball Bearing $\varnothing 4 \times \varnothing 9 \times 2.5 \text{mm}$. - 1 x Thrust Bearing $\varnothing 4 \times \varnothing 9 \times 4 \text{mm}$. - 1 x Socket Head Cap M2x6mm. - 1 x Socket Head Cap M3x6mm. 	<p>Swashplate (H0788-S)</p>  <ul style="list-style-type: none"> - 1 x Swashplate SET. 	<p>Uniball M2x$\varnothing 4 \times \text{H3}$ (H0789-S)</p>  <ul style="list-style-type: none"> - 5 x Uniball M2x$\varnothing 4 \times \text{H3}$. - 1 x Uniball M2x$\varnothing 3 \times \text{H13}$. 	<p>Tail Fin (H0791-S)</p>  <ul style="list-style-type: none"> - 1 x Tail Fin. - 1 x Flanged Bearing $\varnothing 3 \times \varnothing 8 \times 3 \text{mm}$. - 1 x Tail Fin Sticker. 	<p>Spindle (H0792-S)</p>  <ul style="list-style-type: none"> - 1 x Spindle. - 2 x Socket Head Cap M3x6mm. 	<p>Shim $\varnothing 4.5 \times \varnothing 5.9 \times 0.3$ (H0794-S)</p>  <ul style="list-style-type: none"> - 10 x Shim $\varnothing 4.5 \times \varnothing 5.9 \times 0.3 \text{mm}$.
<p>Blade Grip Arm Plastic (H0795-S)</p>  <ul style="list-style-type: none"> - 1 x Blade Grip Arm Plastic. - 1 x DFC Arm. - 1 x Plastic Ball Link. - 2 x Flanged Bearing $\varnothing 2 \times \varnothing 5 \times 2.5$. - 1 x Socket Head Cap M2x8mm. - 1 x Socket Head Cap M2x5mm. 	<p>Servo Linkage (H0796-S)</p>  <ul style="list-style-type: none"> - 3 x Servos Linkage. 	<p>Bell Crank Clever (H0797-S)</p>  <ul style="list-style-type: none"> - 1 x Bell Crank Clever. - 1 x Bushing $\varnothing 2 \times \varnothing 3 \times 3 \text{mm}$. - 1 x Uniball M2x$\varnothing 4 \times \text{H3}$. - 2 x Tail Pin. - 2 x Flanged Bearing $\varnothing 2 \times \varnothing 5 \times 2.5$. - 1 x Socket Head Cap M2x12mm. - 1 x Shim $\varnothing 2.1 \times \varnothing 3.6 \times 0.2 \text{mm}$. 	<p>Tail Blade Grip (H0798-S)</p>  <ul style="list-style-type: none"> - 2 x Tail Blade Grip. - 4 x Bearing $\varnothing 3 \times \varnothing 6 \times 2 \text{mm}$. - 2 x Thrust Bearing $\varnothing 3 \times \varnothing 6 \times 2.8 \text{mm}$. - 2 x Shim $\varnothing 4.5 \times \varnothing 5.9 \times 0.3$. - 2 x Washer $\varnothing 2.5 \times \varnothing 4.5 \times 0.5 \text{mm}$. - 2 x Socket Head Cap M2x5mm. 	<p>Landing Gear (H0799-S)</p>  <ul style="list-style-type: none"> - 1 x Landing Gear. - 4 x Washer $\varnothing 2.5 \times \varnothing 4.5 \times 0.5 \text{mm}$. - 4 x Socket Head Cap M2x8mm. 	<p>Boom (H0818-S)</p>  <ul style="list-style-type: none"> - 1 x Yellow Tail Boom. - 1 x Boom Sticker. - 4 x Washer $\varnothing 2.5 \times \varnothing 4.5 \times 0.5 \text{mm}$. - 4 x Socket Head Cap M2x6mm.

<p>Front Servo Support (H0819-S)</p>  <ul style="list-style-type: none"> - 1 x Front Servo Support. - 1 x Rear Servo Support - 2 x Socket Cap Screws M2x6. - 2 x Socket Cap Screws M2x8. 	<p>Pulley 76T (H0820-S)</p>  <ul style="list-style-type: none"> - 1 x Pulley 76T. - 1 x Button Cap Screws M2x4. 	<p>Canopy (H0831-S)</p>  <ul style="list-style-type: none"> - 1 x Yellow Canopy. - 2 x Button Cap Screws M3x4. 	<p>Frame SX (H0832-S)</p>  <ul style="list-style-type: none"> - 1 x Frame SX Assembled. 	<p>Frame DX (H0833-S)</p>  <ul style="list-style-type: none"> - 1 x Frame DX Assembled. 	<p>Bearing Support (H0837-S)</p>  <ul style="list-style-type: none"> - 1 x Bearing Support. - 2 x Bearing Ø4.765xØ12.7x4.987. 	<p>Main Plate (H0838-S)</p>  <ul style="list-style-type: none"> - 1 x Main Plate. - 2 x Nylon Nut M3.
<p>Feeder (H0839-S)</p>  <ul style="list-style-type: none"> - 1 x Feeder. - 1 x Feeder Damper. - 1 x Set Screw M3x4mm. 	<p>Tail Shaft (H0842-S)</p>  <ul style="list-style-type: none"> - 1 x Tail Shaft. - 1 x Set Screw M2.5x4mm. - 1 x Set Screw M3x4mm. 	<p>Canopy Positioner (H0844-S)</p>  <ul style="list-style-type: none"> - 2 x Canopy Positioner. - 2 x Button Cap Screws M3x4. 	<p>Wire Positions (H0858-S)</p>  <ul style="list-style-type: none"> - 2 x Wire Positions. - 2 x Self Tapping Screw M2.2 x 6mm. - 1 x RX Support. - 1 x Double Side Tape. 	<p>Left Tensioner Support (H0870-S)</p>  <ul style="list-style-type: none"> - 1 x Left Tensioner Support. - 1 x Column Tensioner. - 1 x Tensioner. - 1 x Flat Cap Screw M2.5x5. - 2 x Flanged Bearing 4x7x2.5. - 1 x Special Screw M2.5x6. 	<p>Right Tensioner Support (H0899-S)</p>  <ul style="list-style-type: none"> - 1 x Right Tensioner Support. - 1 x Column Tensioner. - 1 x Tensioner. - 1 x Flat Cap Screw M2.5x5. - 2 x Flanged Bearing 4x7x2.5. - 1 x Special Screw M2.5x6. 	<p>Main Blade 280mm (280TB)</p>  <ul style="list-style-type: none"> - 2 x Main Blade 280mm.

<p>Tail Blade 50mm (H0828-S)</p>  <p>- 2 x Tail Blade 50mm.</p>	<p>Double Side Tape (HA035-S)</p>  <p>- 2 x Double Side Tape 30x100x1mm.</p>	<p>Strap 205x16mm (HA044-S)</p>  <p>- 2 x Strap 205x16mm.</p>	<p>Velcro Tape 36x100mm (HA045-S)</p>  <p>- 1 x Velcro Tape 36x100.</p>	<p>Foam Blade Holder (HA061-S)</p>  <p>- 1 x Foam Blade Holder.</p>	<p>Stickers Set (HA064-S)</p>  <p>- 1 x Stickers Set.</p>	<p>Servo Horn (HA065-S)</p>  <p>- 4 x Servo Horn. - 4 x Servo Screws.</p>	<p>[HC001-S]</p>  <p>- 8 x Button Head Cap Screws M2x4mm.</p>
<p>[HC002-S]</p>  <p>- 8 x Socket Head Cap Screws M2x5mm.</p>	<p>[HC004-S]</p>  <p>- 8 x Socket Head Cap Screws M2x6mm.</p>	<p>[HC008-S]</p>  <p>- 8 x Socket Head Cap Screws M2x8mm.</p>	<p>[HC010-S]</p>  <p>- 8 x Socket Head Cap Screws M2x10mm.</p>	<p>[HC014-S]</p>  <p>- 8 x Socket Head Cap Screws M2x12mm.</p>	<p>[HC018-S]</p>  <p>- 8 x Socket Head Cap Screws M2.5x6mm.</p>	<p>[HC019-S]</p>  <p>- 8 x Special Screw M2.5x6.</p>	<p>[HC020-S]</p>  <p>- 8 x Socket Head Cap Screws M2.5x8mm.</p>

<p>[HC031-S]</p>  <p>- 5 x Socket Head Cap Shoulder M2.5x15.</p>	<p>[HC038-S]</p>  <p>- 8 x Button Cap Head Screw M3x4mm.</p>	<p>[HC044-S]</p>  <p>- 8 x Socket Cap Head Screw M3x6mm.</p>	<p>[HC056-S]</p>  <p>- 8 x Socket Cap Head Screw M3x10mm.</p>	<p>[HC128-S]</p>  <p>- 8 x Flat Head Cap Screw M2.5x5mm.</p>	<p>[HC200-S]</p>  <p>- 10 x Nylon Nut M2.5.</p>	<p>[HC206-S]</p>  <p>- 10 x Nylon Nut M3.</p>	<p>[HC403-S]</p>  <p>- 4 x Ball Bearing Ø4xØ9x2.5mm.</p>
<p>[HC434-S]</p>  <p>- 2 x Thrust Bearing Ø4xØ9x4mm.</p>	<p>[HC448-S]</p>  <p>- 2 x Thrust Bearing Ø3xØ6x2,8mm.</p>	<p>[HC450-S]</p>  <p>- 8 x Shims Ø5xØ7x0,1mm.</p>	<p>[HC456-S]</p>  <p>- 4 x Flanged Bearing Ø2xØ5x2.5mm.</p>	<p>[HC485-S]</p>  <p>- 4 x Flanged Bearing Ø3xØ8x3mm.</p>	<p>[HC486-S]</p>  <p>- 2 x Flanged Bearing Ø4xØ7x2.5mm.</p>	<p>[HC487-S]</p>  <p>- 4 x Ball Bearing Ø3xØ6x2mm.</p>	<p>[HC488-S]</p>  <p>- 2 x Ball Bearing Ø4.765xØ12.7x4.987.</p>

<p>[HC489-S]</p>  <p>- 1 x Carbon Rod $\varnothing 1.8 \times \varnothing 3 \times 276 \text{mm}$. - 2 x Linkage M2x22. - 2 x Uniball Arm.</p>	<p>[HC490-S]</p>  <p>- 10 x Socket Self Tapping Screw M2.2 x 6.</p>	<p>[HC491-S]</p>  <p>- 1 x Tail Belt HTD 2M 850mm.</p>	<p>[HC492-S]</p>  <p>- 8 x Nylon Nut M2.</p>	<p>[HC497-S]</p>  <p>- 8 x Socket Head Cap Screw M1.6x5mm.</p>	<p>[HC499-S]</p>  <p>- 8 x Set Screws M2.5x4.</p>	<p>[HC500-S]</p>  <p>- 8 x Set Screws M3x4.</p>	<p>[HC501-S]</p>  <p>- 4 x Damper 70 Shore.</p>		
<p>[HC502-S]</p>  <p>- 4 x Damper 90 Shore.</p>	<p>[HC504-S]</p>  <p>- 2 x Motor Seeger.</p>	<p>[HC508-S]</p>  <p>- 8 x Shims $\varnothing 2.1 \times \varnothing 3.6 \times 0.2 \text{mm}$.</p>	<p>[HE014-S]</p>  <p>- 1 x SAB Standard Motor.</p>	<p>[HE015-S]</p>  <p>- 1 x SAB Competition Motor.</p>	<p>[HE018-S]</p>  <p>- 1 x Cyclic Servo DS12C.</p>	<p>[HE019-S]</p>  <p>- 1 x Tail Servo DS12T.</p>	<p>[HE020-S]</p>  <p>- 1 x Gear Set Tail Servo DS12T.</p>	<p>[HE021-S]</p>  <p>- 1 x Gear Set Cyclic Servo DS12C.</p>	<p>[HE022-S]</p>  <p>- 1 x SAB ESC 60A V4.</p>



Carefully check your model before each flight to ensure it is airworthy.

Consider flying only in areas dedicated to the use of model helicopters.

Check and inspect the flying area to ensure it is clear of people and obstacles.

Rotor blades can rotate at very high speeds! Be aware of the danger they pose.

Always keep the model at a safe distance from other pilots and spectators.

Avoid maneuvers with trajectories towards a crowd.

Always maintain a safe distance from the model.



WWW.GOBLIN-HELICOPTER.COM

SAB HELI DIVISION

GOBLIN FIREBALL

Release 1.0 - July 2017

WORLD DISTRIBUTION

www.goblin-helicopter.com

For sales inquiries, please email:

sales@goblin-helicopter.com

For info inquiries, please email:

support@goblin-helicopter.com

Attention: If you are a customer and have questions or need of assistance, please contact in a first time the Goblin retailer where you made the purchase.

EUROPEAN DISTRIBUTION

www.sabitaly.it

For sales inquiries, please email:

sales@sabitaly.it

For info inquiries, please email:

info@sabitaly.it

Attention: If you are a customer and have questions or need of assistance, please contact in a first time the Goblin retailer where you made the purchase.