

GOBLIN

HELICOPTER

MANUAL
GOBLIN 420



- Carefully check your model before each flight to ensure it is airworthy.
- Consider flying only in areas dedicated to the use of model helicopters.
- Check and inspect the flying area to ensure it is clear of people or obstacles.
- Rotor blades can rotate at very high speeds! Be aware of the danger they pose.
- Always keep the model at a safe distance from other pilots and spectators.
- Avoid maneuvers with trajectories towards a crowd.
- Always maintain a safe distance from the model.



SAB HELI DIVISION

Goblin 420 Manual

Release 1.1 - October 2016

WORLD DISTRIBUTION

www.goblin-helicopter.com

For sales inquiries, please email: sales@goblin-helicopter.com

For information, please email: support@goblin-helicopter.com

Attention: If you are a consumer and have questions or need of assistance,
please contact the retailer where you made the purchased first.

EUROPEAN DISTRIBUTION

www.sabitaly.it

For sales inquiries, please email: sales@sabitaly.it

For information, please email: info@sabitaly.it

Attention: If you are a consumer and have questions or need of assistance,
please contact the retailer where you made the purchased first.

Please read this user manual carefully, it contains instructions for the correct assembly of the model.
Please refer to the web site www.goblin-helicopter.com for updates and other important information.

VERY IMPORTANT

In the Manual bag you will find a product card your with serial number. Please take a moment to register your kit online via our web site at:

<http://www.goblin-helicopter.com>



It is extremely important that you take a moment to register your helicopter with us. This is the only way to ensure that you are properly informed about changes to your kit, such as upgrades, retrofits and other important developments. SAB Heli Division cannot be held responsible for issues arising with your model and will not provide support unless you register your serial number.

The Serial number is also engraved in the Aluminum Main Plate.

Thank you for your purchase, we hope you enjoy your new Goblin helicopter!

SAB Heli Division

INDEX

- | | | |
|------------------------------|---|---------------------------------------|
| 1 – Specifications | 7 – Assembling The Modules | 13 – Tail Assembly |
| 2 – Important Notes ⚠ | 8 – Installation of Swashplate Servos | 14 – Installation of the Boom, Canopy |
| 3 – Components and Box | 9 – Tail Servo Assembly | 15 – Battery |
| 4 – Carbon frame Assembly | 10 – Installation of The Motor | 16 – In flight ⚠ |
| 5 – Transmission Assembly | 11 – Installation of The ESC | 17 – Maintenance |
| 6 – Main Rotor Assembly | 12 – Installation of Flybarless Unit and RX | 18 – Exploded Views |
| | | 19 – Spare Parts |

SPECIFICATIONS



- Main rotor diameter : 936mm.
- Main blade length : 420mm.
- Tail rotor diameter : 192mm.
- Tail blade length : 70mm.
- Main shaft diameter : 8mm.
- Tail shaft diameter : 5mm.
- Spindle diameter : 5mm.
- Motor size: Maximum 41mm diameter, maximum height 41mm.
- Battery compartment: 44x44x130mm.

IMPORTANT NOTES

- *This radio controlled helicopter is not a toy.
- *This radio controlled helicopter can be very dangerous.
- *This radio controlled helicopter is a technically complex device which has to be built and handled very carefully.
- *This radio controlled helicopter must be built following these instructions. This manual provides the necessary information to correctly assemble the model. It is necessary to carefully follow all the instructions.
- *Inexperienced pilots must be monitored by expert pilots.
- *All operators must wear safety glasses and take appropriate safety precautions.
- *A radio controlled helicopter must only be used in open spaces without obstacles, and far enough from people to minimize the possibility of accidents or of injury to property or persons.
- *A radio controlled helicopter can behave in an unexpected manner, causing loss of control of the model, making it very dangerous.
- *Lack of care with assembly or maintenance can result in an unreliable and dangerous model.

***Neither SAB Heli Division nor its agents have any control over the assembly, maintenance and use of this product. Therefore, no responsibility can be traced back to the manufacturer. You hereby agree to release SAB Heli Division from any responsibility or liability arising from the use of this product.**

SAFETY GUIDELINES

- *Fly only in areas dedicated to the use of model helicopters.
- *Follow all control procedures for the radio frequency system.
- *It is necessary that you know your radio system well. Check all functions of the transmitter before every flight.
- *The blades of the model rotate at a very high speed; be aware of the danger they pose and the damage they may cause.
- *Never fly in the vicinity of other people.

LIMITED WARRANTY.

SAB Heli Division reserves the right to change or modify this warranty without notice and disclaims all other warranties, express or implied.

(a) This warranty is limited to the original Purchaser ("Purchaser") and is not transferable. REPLACEMENT AS PROVIDED UNDER THIS WARRANTY IS THE EXCLUSIVE REMEDY OF THE PURCHASER This warranty covers only those Products purchased from an authorized SAB Heli Division dealer. Third party transactions are not covered by this warranty. Proof of purchase is required for warranty claims.

(b) Limitations- SAB HELI DIVISION MAKES NO WARRANTY OR REPRESENTATION, EXPRESS OR IMPLIED, ABOUT NONINFRINGEMENT, MERCHANTABILITY OR FITNESS FOR A PARTICULAR PURPOSE OF THE PRODUCT. THE PURCHASER ACKNOWLEDGES THAT THEY ALONE HAVE DETERMINED THAT THE PRODUCT WILL SUITABLY MEET THE REQUIREMENTS OF THE PURCHASER'S INTENDED USE.

(c) Purchaser Remedy- SAB Heli Division's sole obligation hereunder shall be that SAB Heli Division will, at its option, replace any Product determined by SAB Heli Division to be defective In the event of a defect, this is the Purchaser's exclusive remedy. Replacement decisions are at the sole discretion of SAB Heli Division. This warranty does not cover cosmetic damage or damage due to acts of God, accident, misuse, abuse, negligence, commercial use, or modification of or to any part of the Product. This warranty does not cover damage due to improper installation, operation, maintenance or attempted repair by anyone

DAMAGE LIMITS.

SAB HELI DIVISION SHALL NOT BE LIABLE FOR SPECIAL, INDIRECT OR CONSEQUENTIAL DAMAGES, LOSS OF PROFITS OR PRODUCTION OR COMMERCIAL LOSS IN ANY WAY CONNECTED WITH THE PRODUCT, WHETHER SUCH CLAIM IS BASED IN CONTRACT, WARRANTY, NEGLIGENCE, OR STRICT LIABILITY. Further, in no event shall the liability of SAB Heli Division exceed the individual price of the Product on which liability is asserted. As SAB Heli Division has no control over use, setup, final assembly, modification or misuse, no liability shall be assumed nor accepted for any resulting damage or injury. By the act of use, setup or assembly the user accepts all resulting liability. If you as the Purchaser or user are not prepared to accept the liability associated with the use of this Product, you are advised to return this Product immediately in new and unused condition to the place of purchase.

NOTES FOR ASSEMBLY

Please refer to this manual for assembly instructions for this model.

Follow the order of assembly indicated. The instructions are divided into chapters, which are structured in a way that each step is based on the work done in the previous step. Changing the order of assembly may result in additional or unnecessary steps.

Use thread lockers and retaining compounds as indicated. In general, each bolt or screw that engages with a metal part requires thread lock.

It is necessary to pay attention to the symbols listed below:

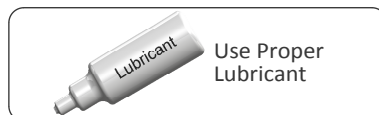
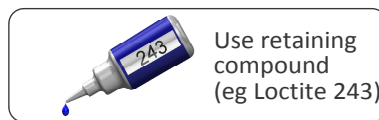
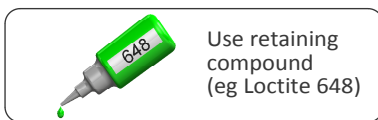
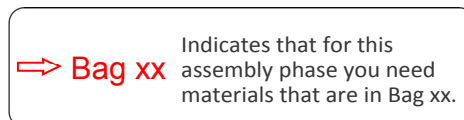

ADDITIONAL COMPONENTS REQUIRED

- *Electric Motor: 850 - 1000Kv:
Maximum diameter 41mm.
Maximum height 41mm.
Pinion shaft diameter 5 mm.
- *Speed controller: minimum 70A , extreme 3D Flight 80-100A.
- *Batteries: 6S-2100 mAh (1800 - 2600 mAh) .
- *1 flybarless 3 axis control unit.
- *Radio power system, if not integrated with the ESC.
- *3 micro cyclic servos.
- *1 mini (midi) tail rotor servo.
- *6 channel radio control system on 2.4 GHz.

(See configuration examples on page 14).

TOOLS, LUBRICANTS, ADHESIVES

- *Generic pliers.
- *Hexagonal driver, size 1.5,2,2.5mm.
- *5.5mm Socket wrench (for M3 nuts).
- *7mm Hex fork wrench (for M4 nuts).
- *Medium threadlocker (eg. Loctite 243).
- *Strong retaining compound (eg. Loctite 648).
- *Spray lubricant (eg. Try-Flow Oil).
- *Grease (eg. Microlube GL261).
- *Cyanoacrylate adhesive.
- *Pitch Gauge (for set-up).
- *Soldering equipment (for motor and ESC wiring).

Inside the main box there are:

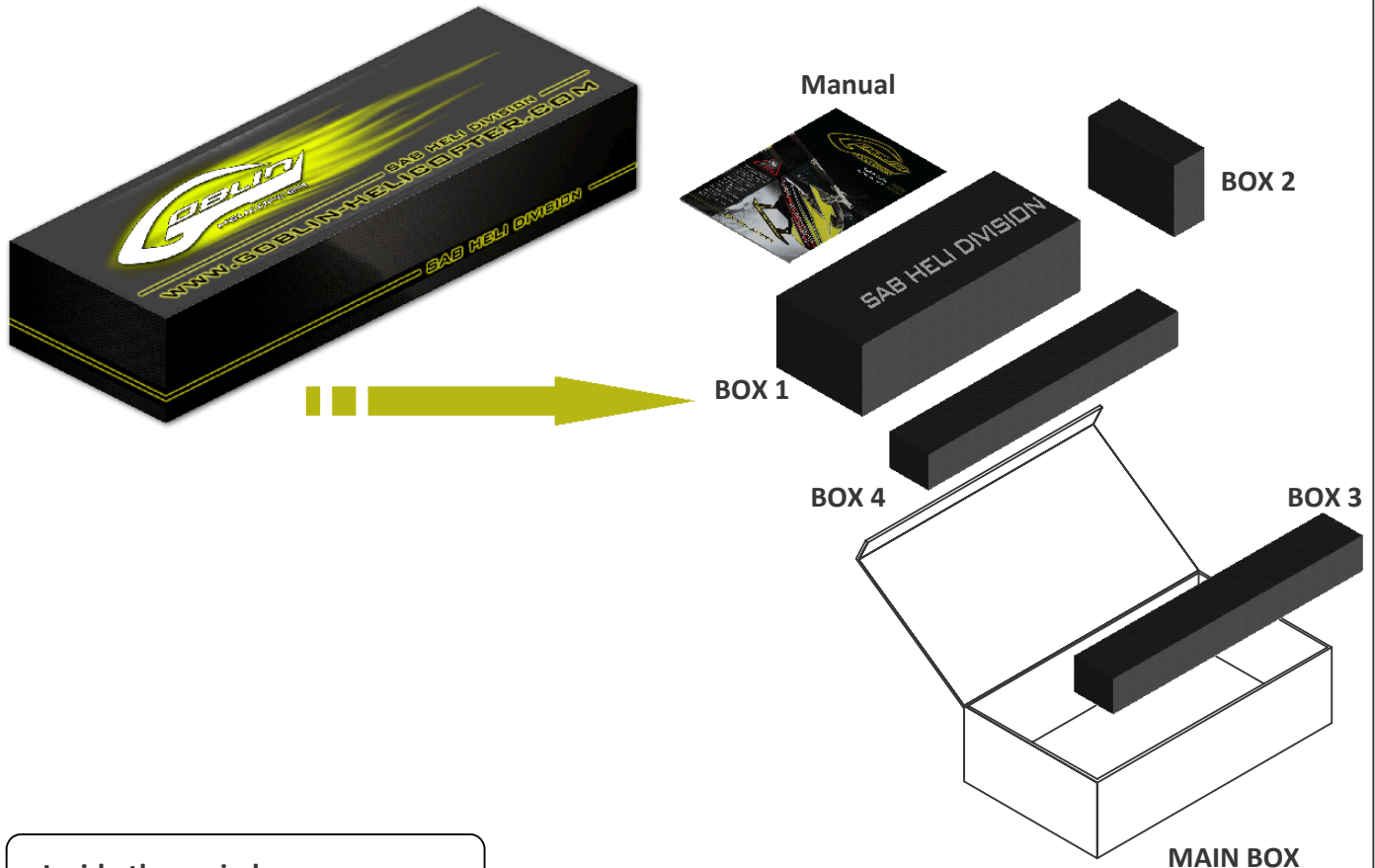

Inside the main box:

- Box 1: Canopy.
Frames.
Blade Holder.
Landing Gear.
Battery Support.
Tail Fin Assembly.
- Box 2: Combo Components (Optional).
- Box 3: Boom.
Carbon Rod.
Blades + Tail Blades.
- Box 4: Mechanical parts, Bags.

The assembly process is described in the following chapters. Each chapter provides you with the box and bag you will need for that chapter. The information is printed at the top of every page.

4-Carbon Frame



The manufacturing process of the carbon parts often leaves micro-burrs and sharp edges. We recommend de-burring the edges to minimize the risks of electrical wire cuts, etc. This is particularly important in the areas shown in red.

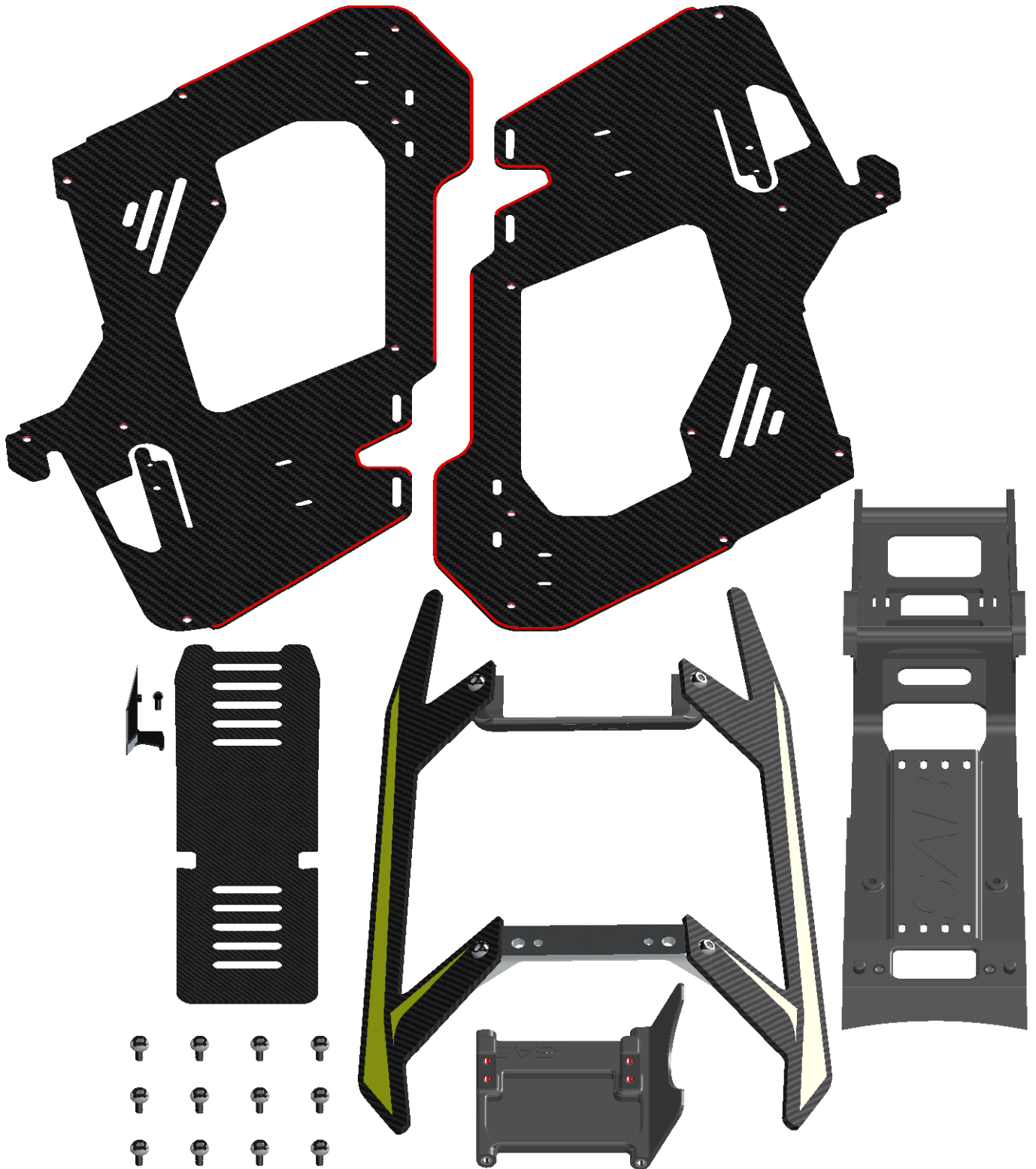

Left Main Frame Assembly

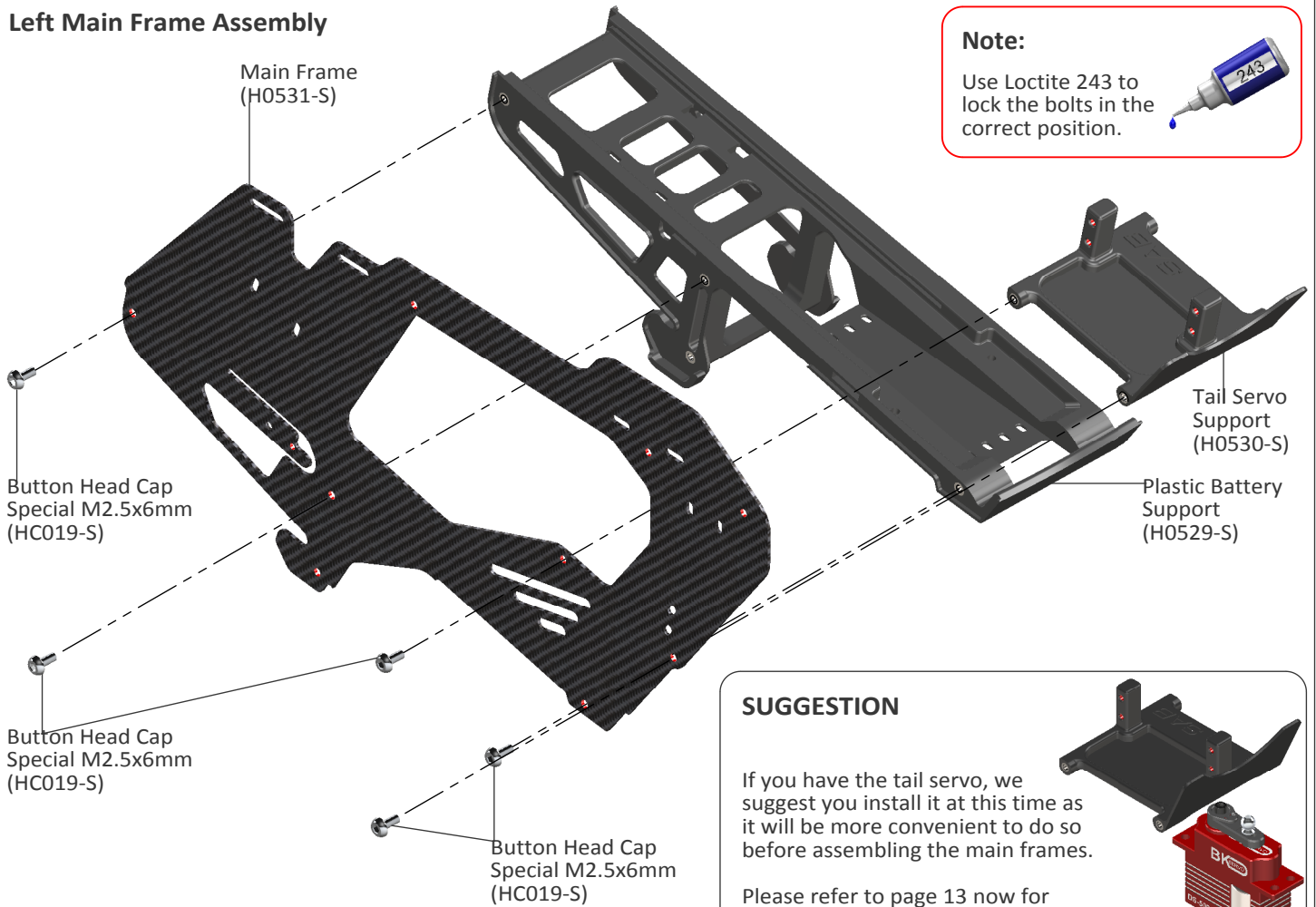

Note:

Use Loctite 243 to lock the bolts in the correct position.



SUGGESTION

If you have the tail servo, we suggest you install it at this time as it will be more convenient to do so before assembling the main frames.

Please refer to page 13 now for more information.

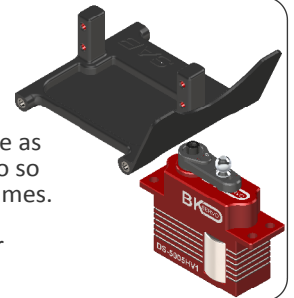

Main Frame Assembly

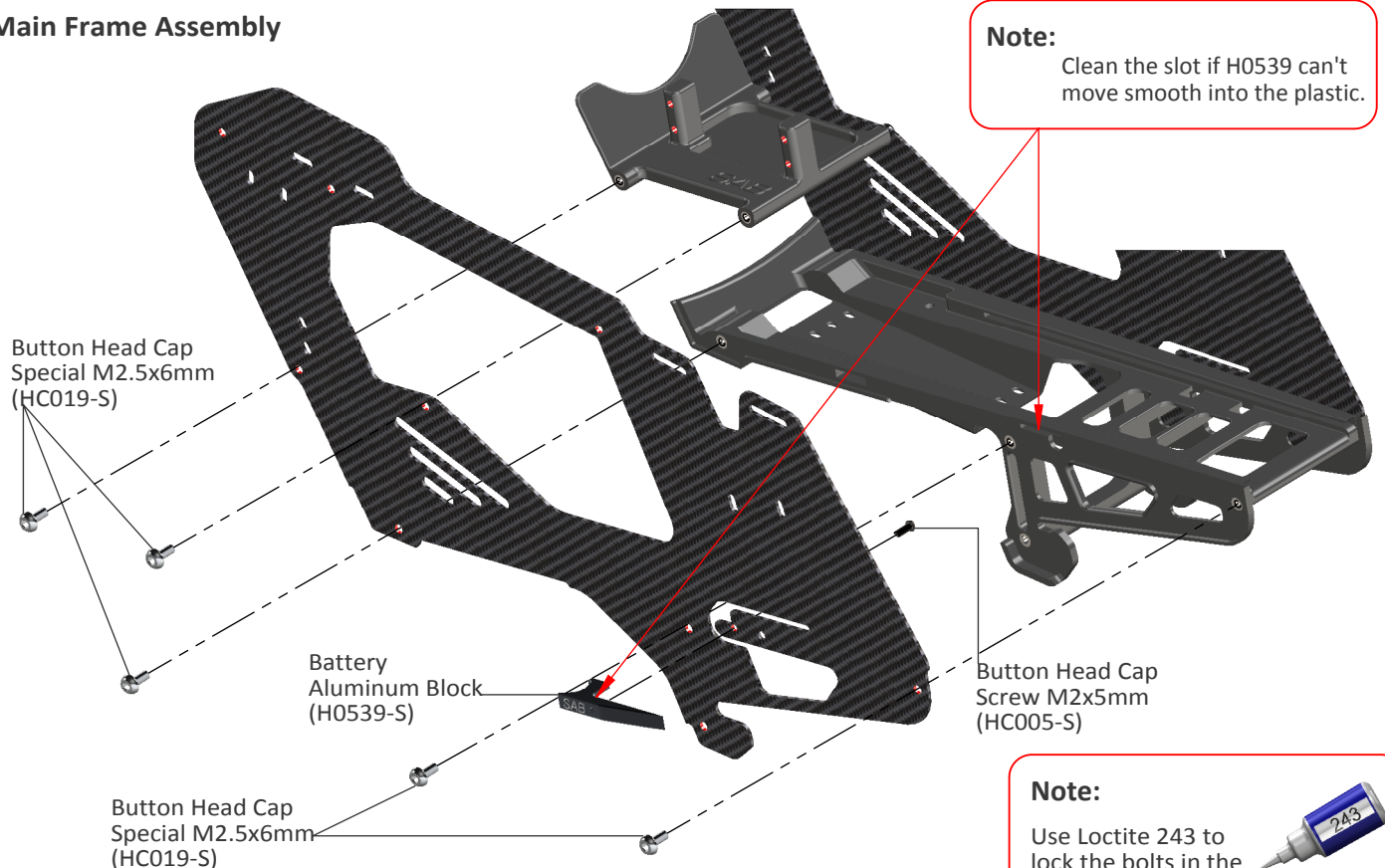

Note:

Clean the slot if H0539 can't move smooth into the plastic.

Note:

Use Loctite 243 to lock the bolts in the correct position.



Landing Gear Assembly

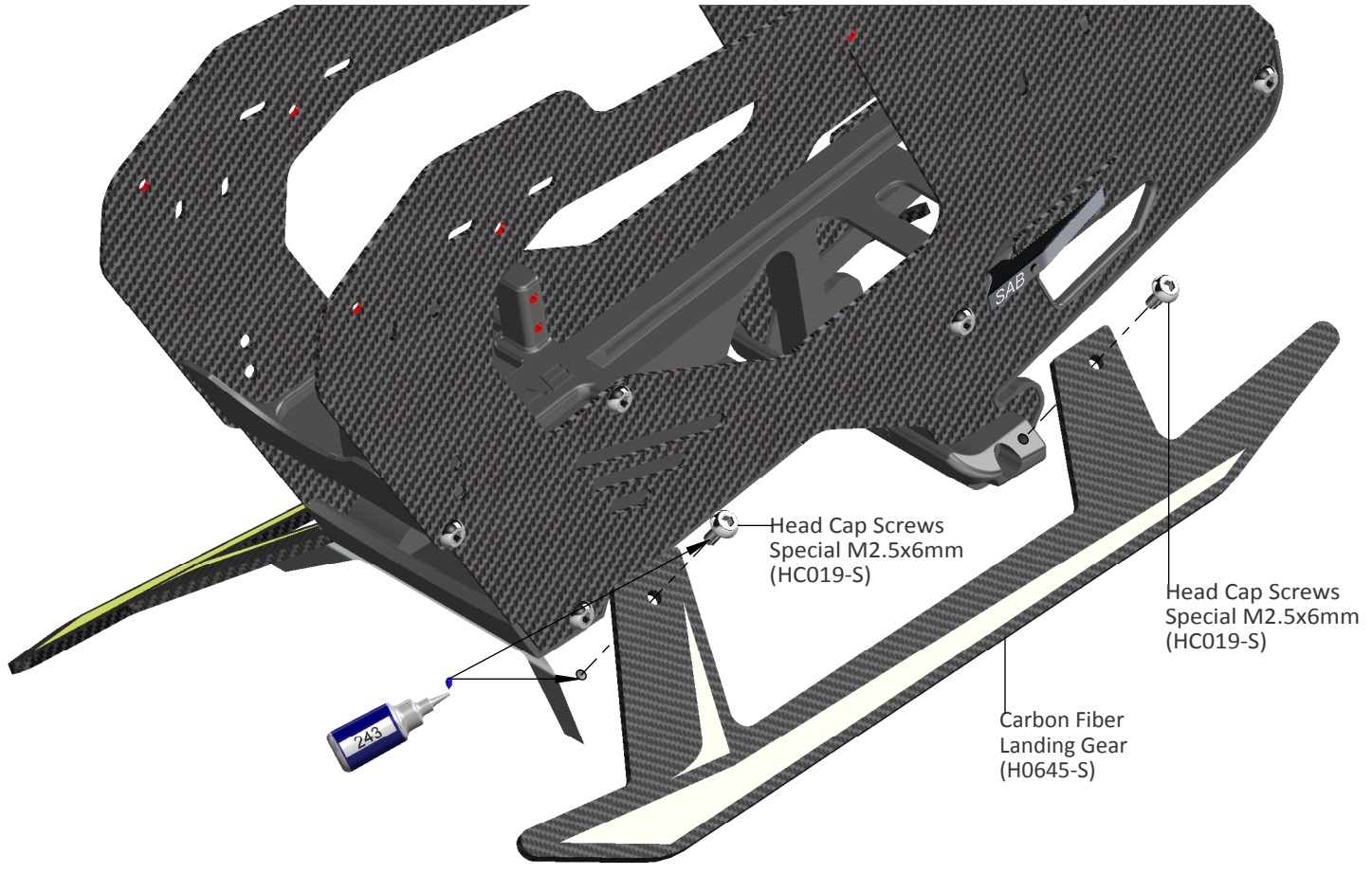
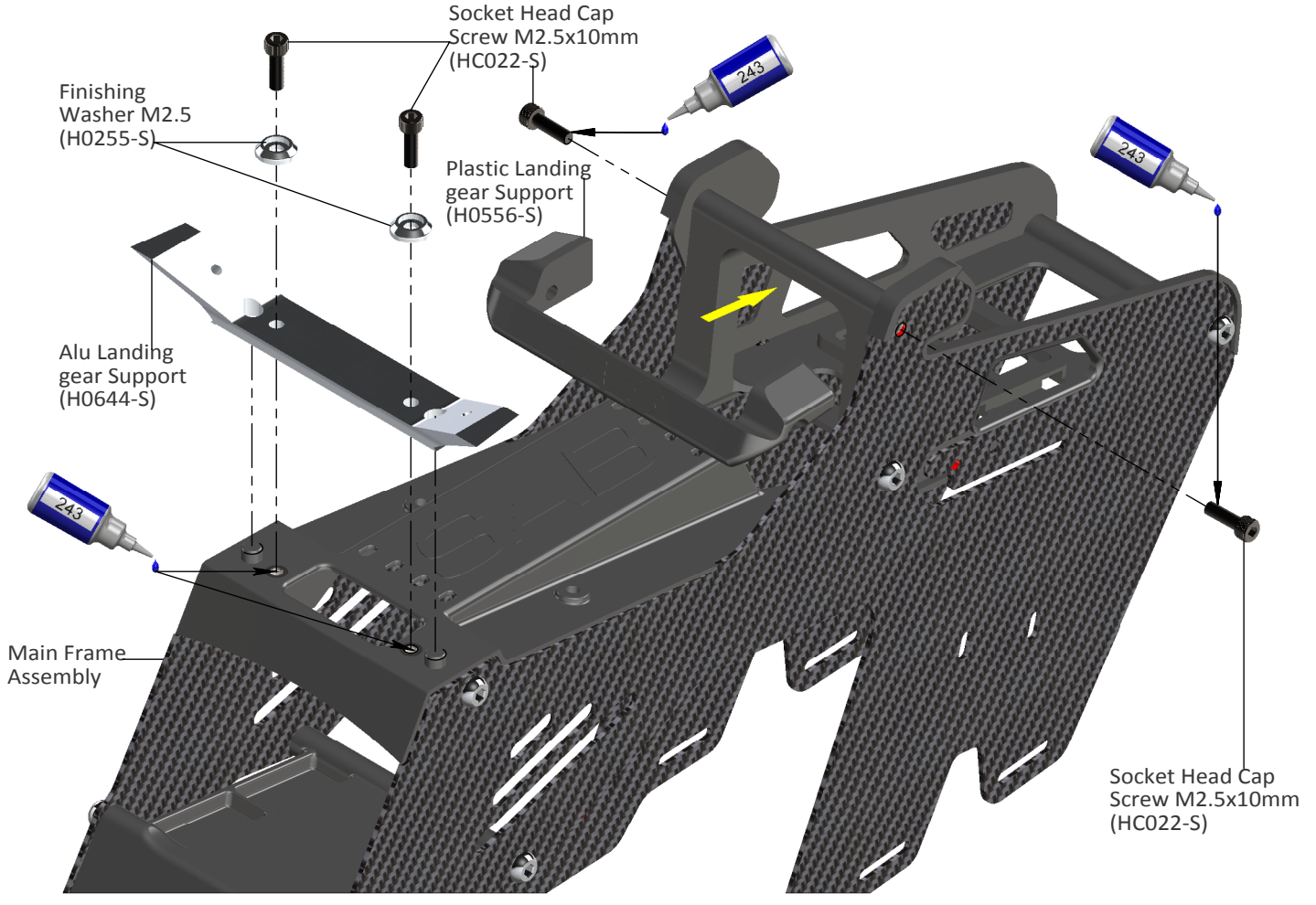

Main Shaft Support Assembly

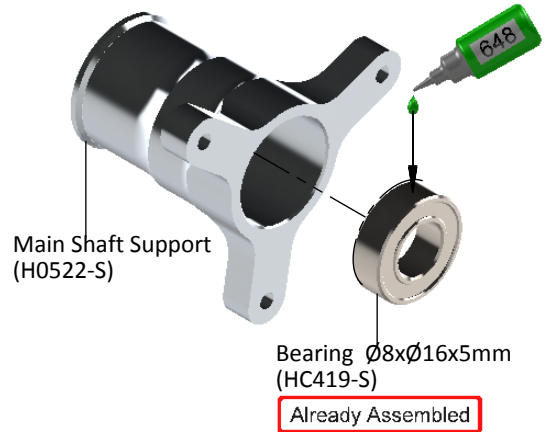

Main Shaft Assembly

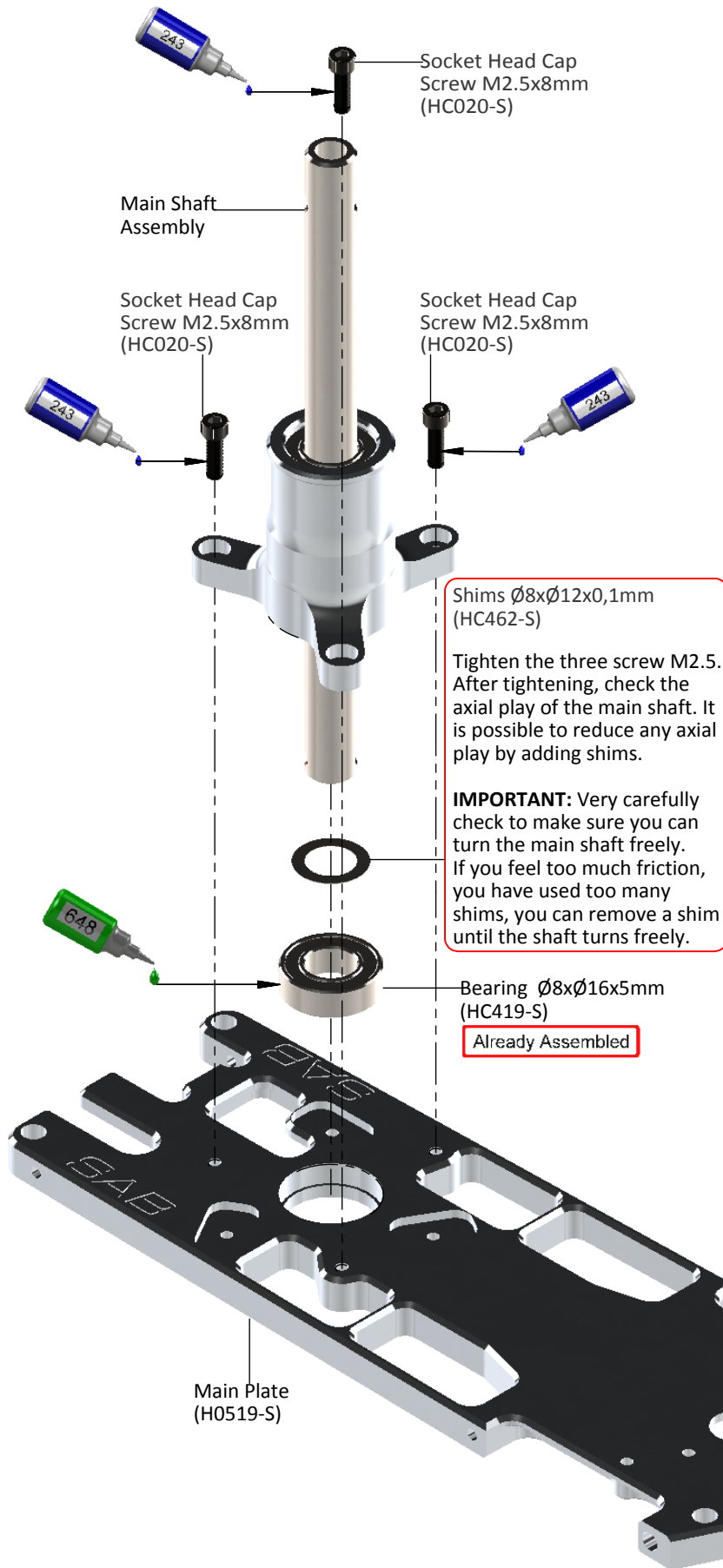
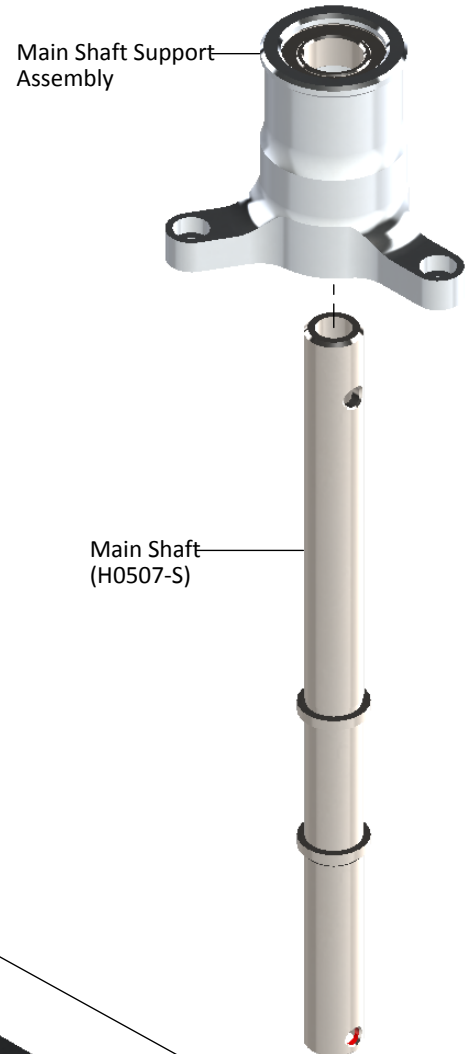



120T Pulley Assembly (H0502-S)

Already Assembled

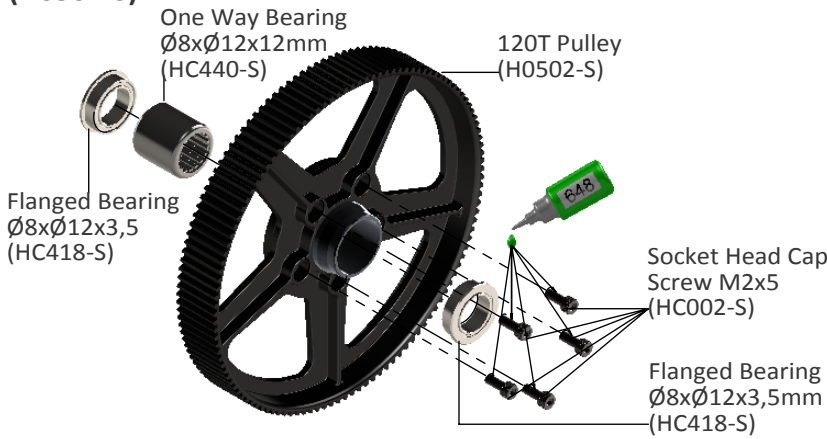

Front Tail Pulley Assembly (H0620-S)

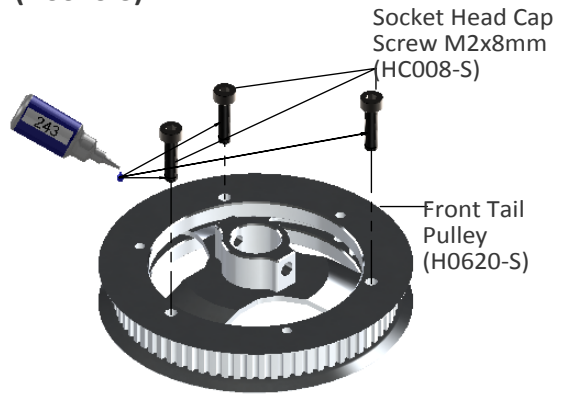

Tail Belt Idler Assembly

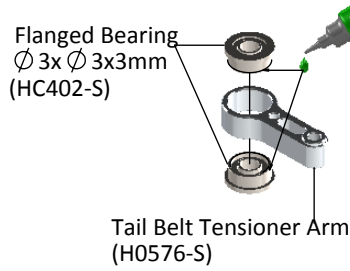

Tail Belt Tensioner Arm Assembly

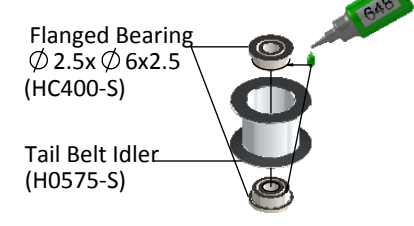

NOTE:
Lock the tension group in this position (Position without preload).

Orientation H0577

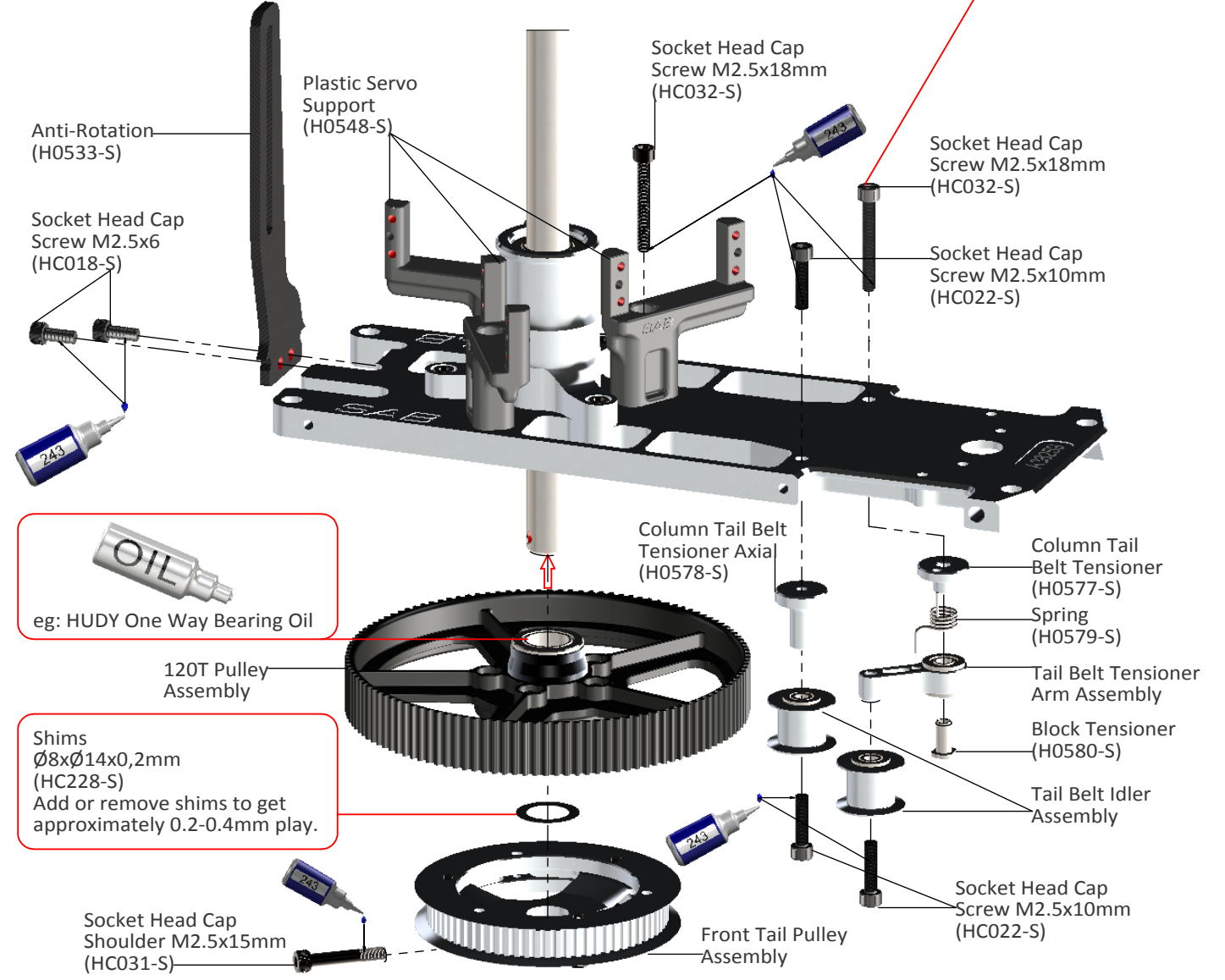

Radius Arm Assembly ... x 2

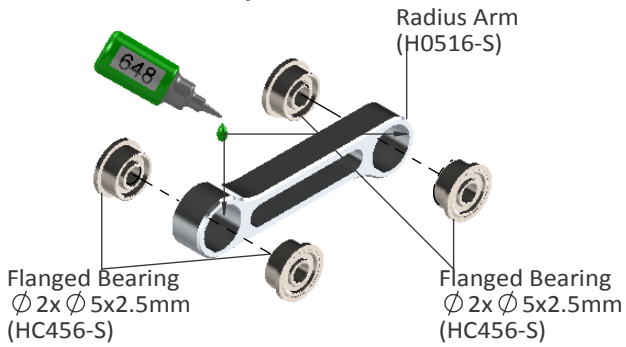

Radius Plastic Arm Assembly ... x 2

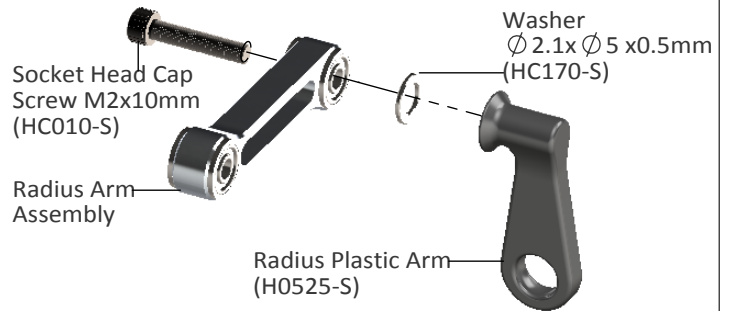

NOTE: Tighten with care, the arm must move freely.

Center Hub Assembly

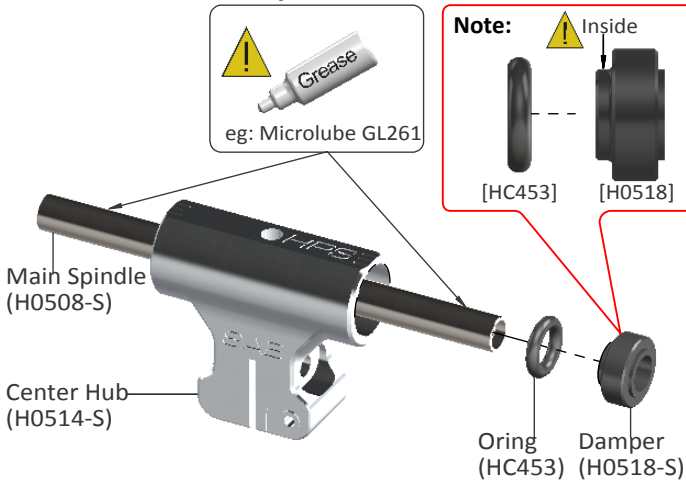

Main Blade Grip Assemblyx2

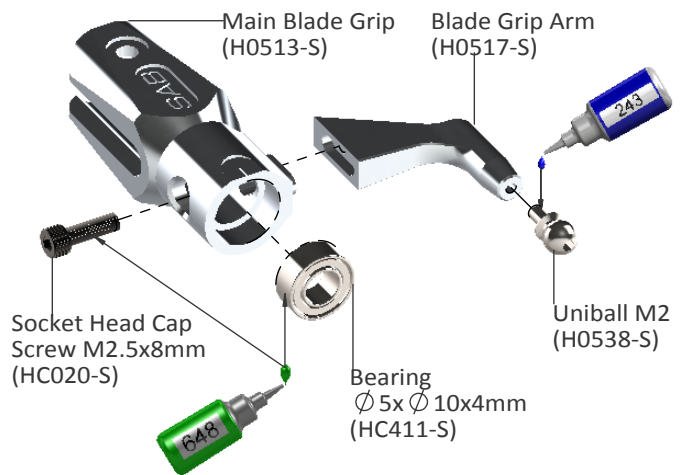

Head HPS Assembly

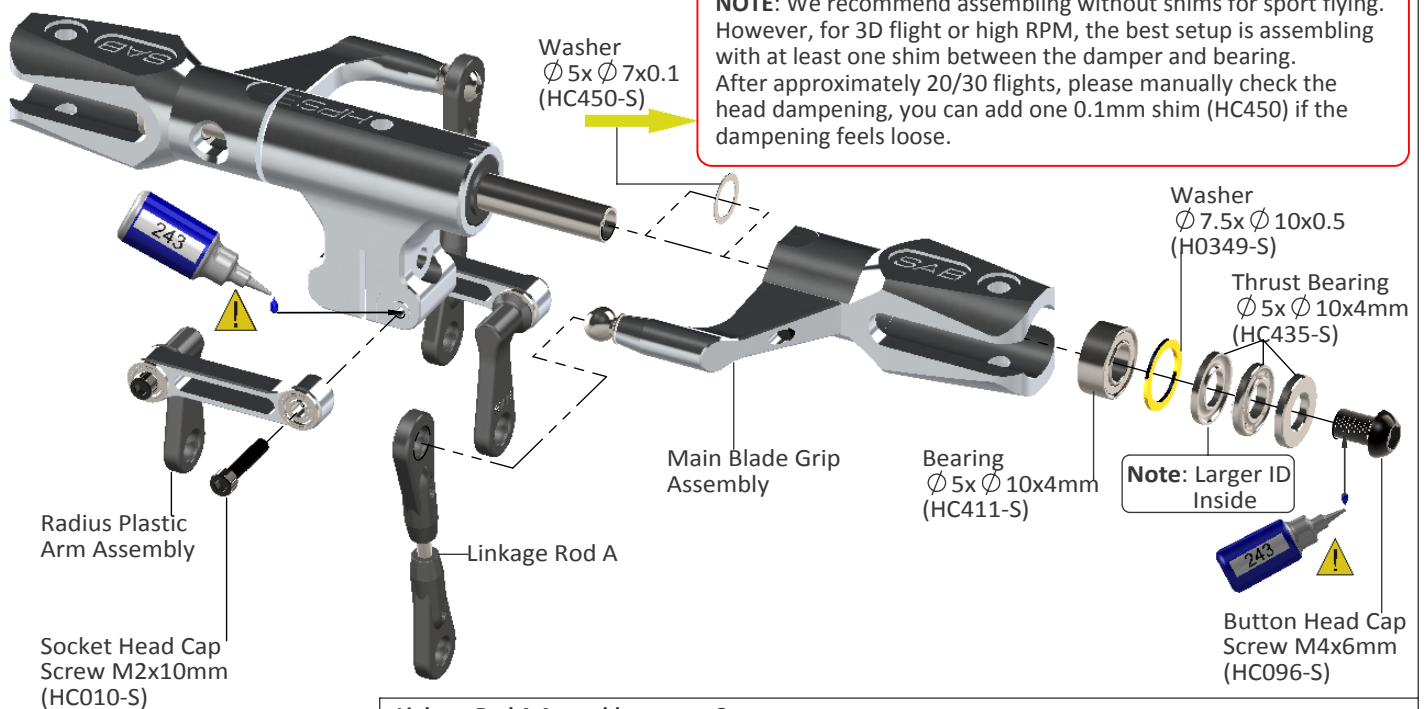

NOTE: We recommend assembling without shims for sport flying. However, for 3D flight or high RPM, the best setup is assembling with at least one shim between the damper and bearing. After approximately 20/30 flights, please manually check the head dampening, you can add one 0.1mm shim (HC450) if the dampening feels loose.

Linkage Rod A Assemblyx2

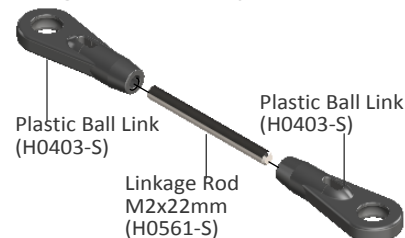

(Initial length for the rods from the swashplate to the Blade Grip.)

Swashplate Assembly

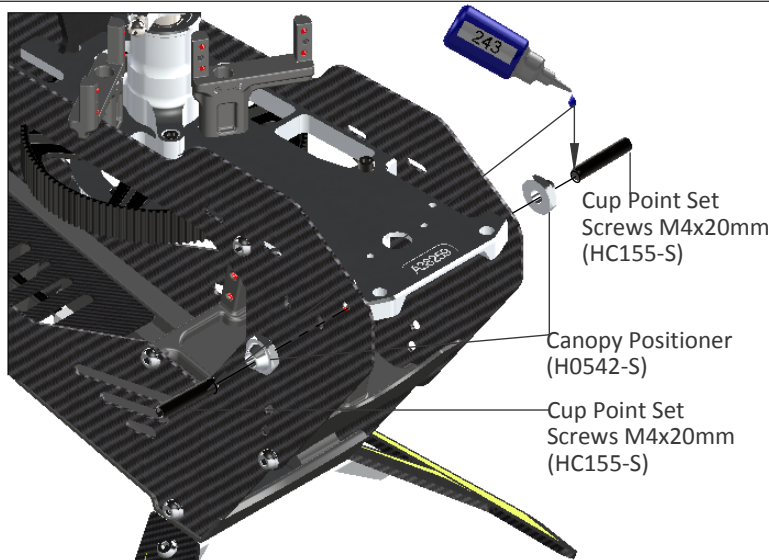
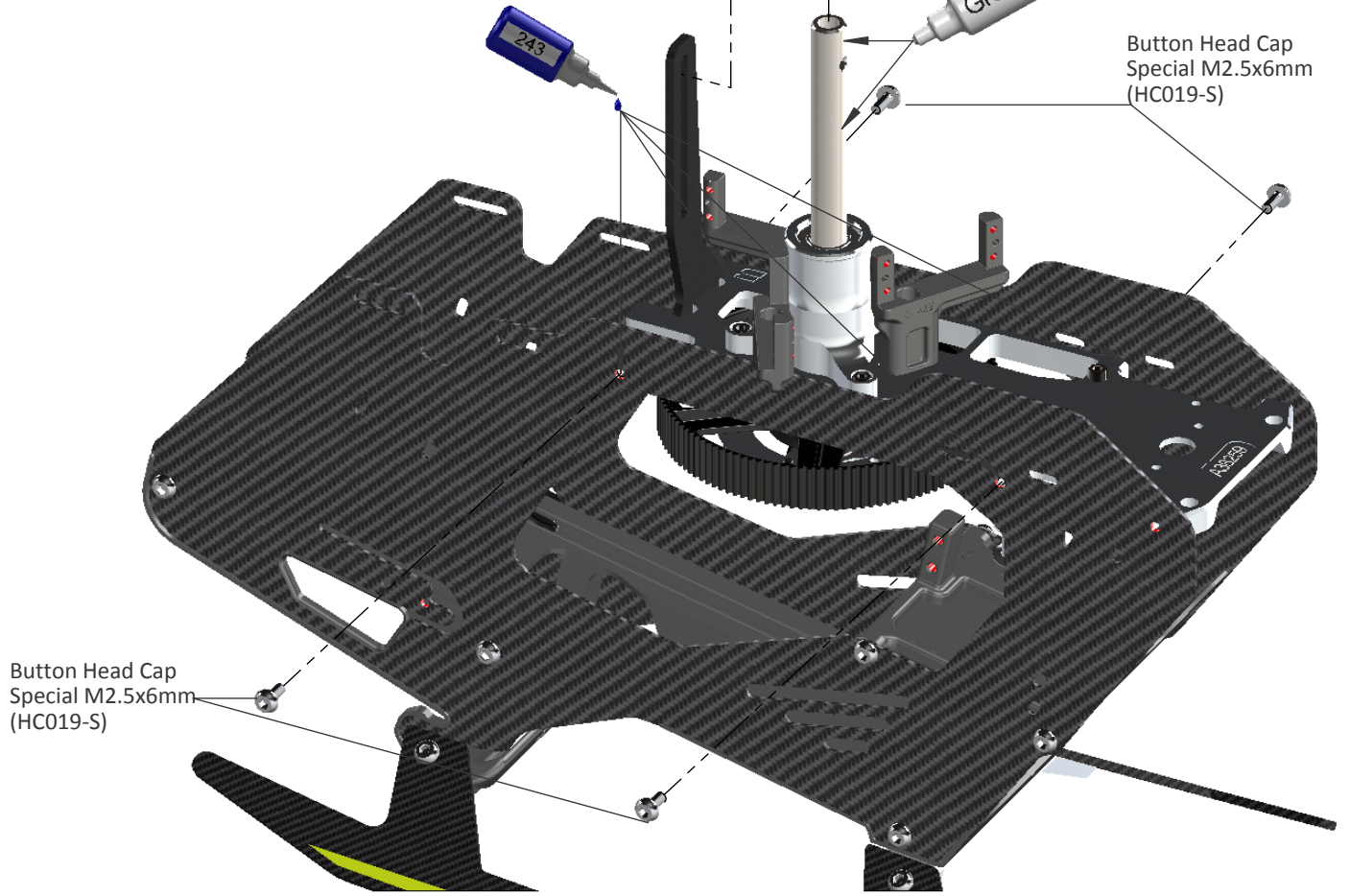
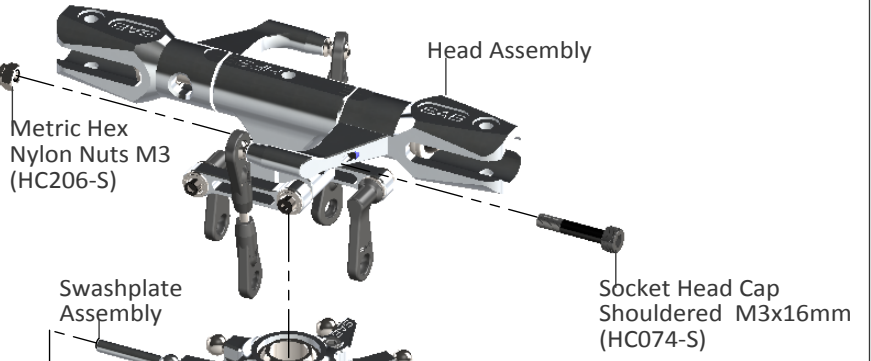
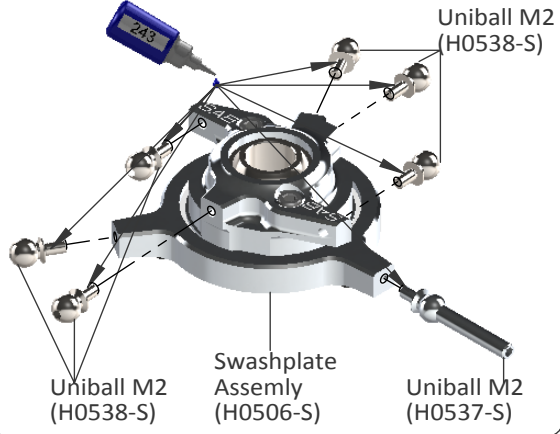

NOTE:

Keep the distance between the end of the canopy retainer H0542 and the frame at approximately 12mm.

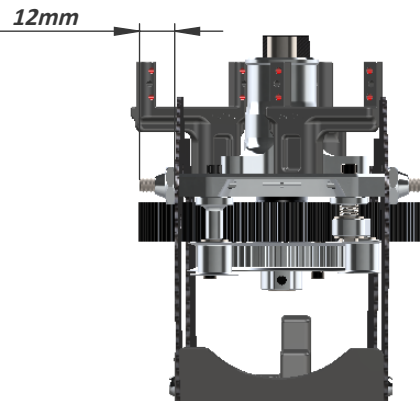

INSTALLATION OF SWASHPLATE SERVOS

The linkage ball must be positioned approximately **13-15 mm** out on the servo arm (**figure 1**), it is recommended to use the SAB servo arm p/n [HA052]. Because of the 120° placement of the servos in the Goblin, the arms are difficult to access. For this reason it is advisable to ensure alignment of the servo arms (and sub trim) before installation of the servos in the model (**figure 2**). Proceed with installation following the instructions below. **Figure 3** shows a completed installation.

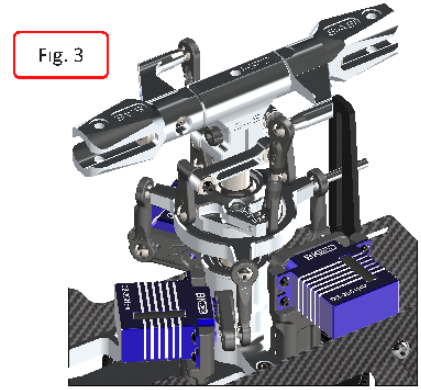
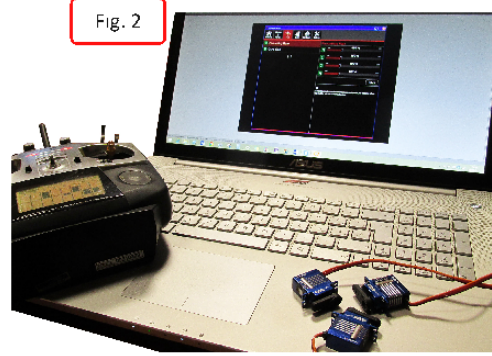

The rods going from the servos to the swash plate must be as vertical as possible. (Red line in Figure 4)
 Not all servos are equal, so for proper alignment you can choose to use the supplied spacer H0566 under the uniball H0538.

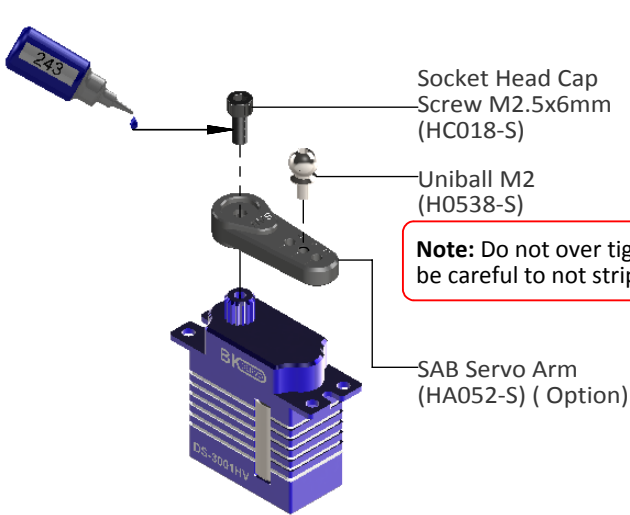

Note: Do not over tighten, be careful to not strip plastic.

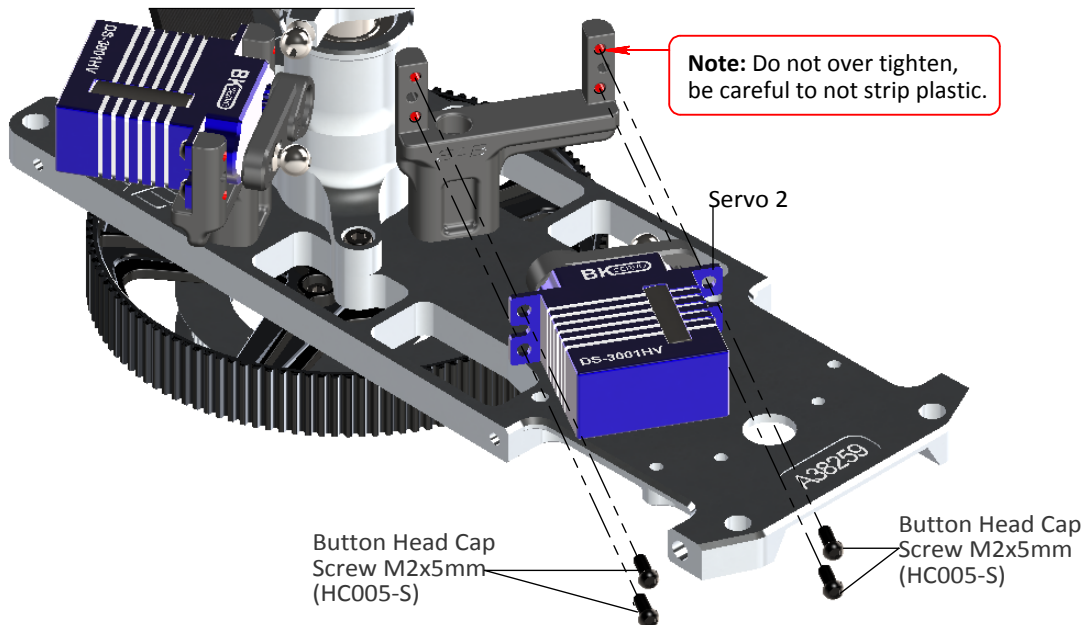
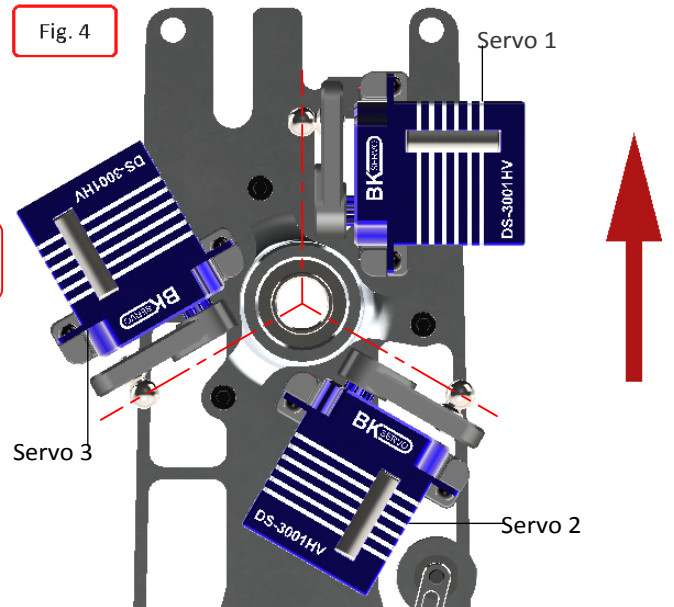

Note: Do not over tighten, be careful to not strip plastic.

Tip on cable routing

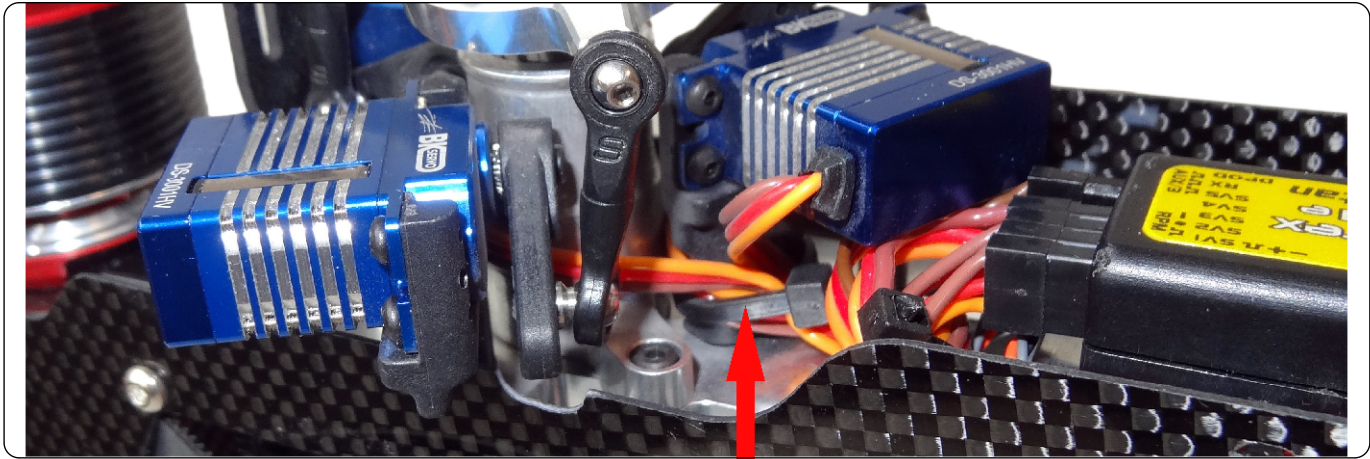

You can use zip-ties to secure the 3 servo cables to the servo support.

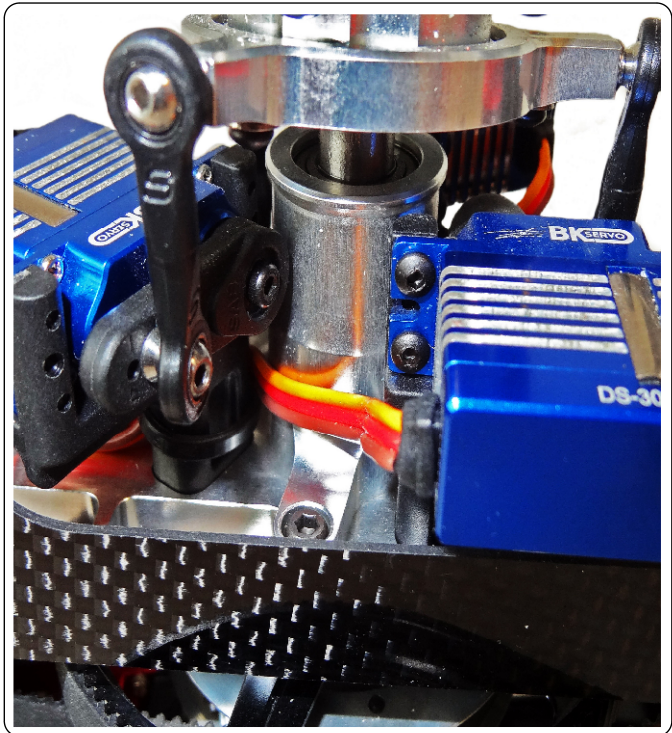

HPS Head Preliminary Setup

Linkage Rod A Assembly ... x2

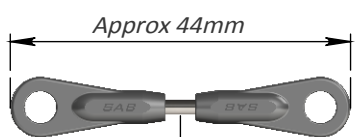

Linkage Rod M2x22mm (H0561-S)

Initial length for the rods from the swashplate to the blade grips.

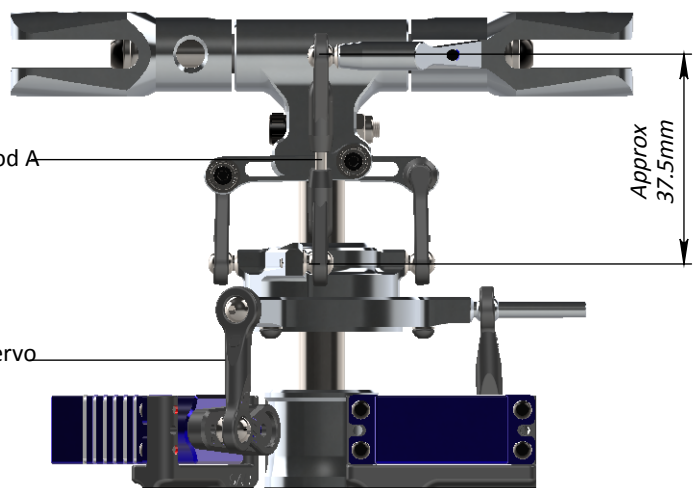

Linkage Rod A Assembly

Linkage Servo (H0524-S)

Approx 37.5mm

The distance between the servo spline and the ball must be between 13-15 mm
You can use the SAB servo horn [HA053].

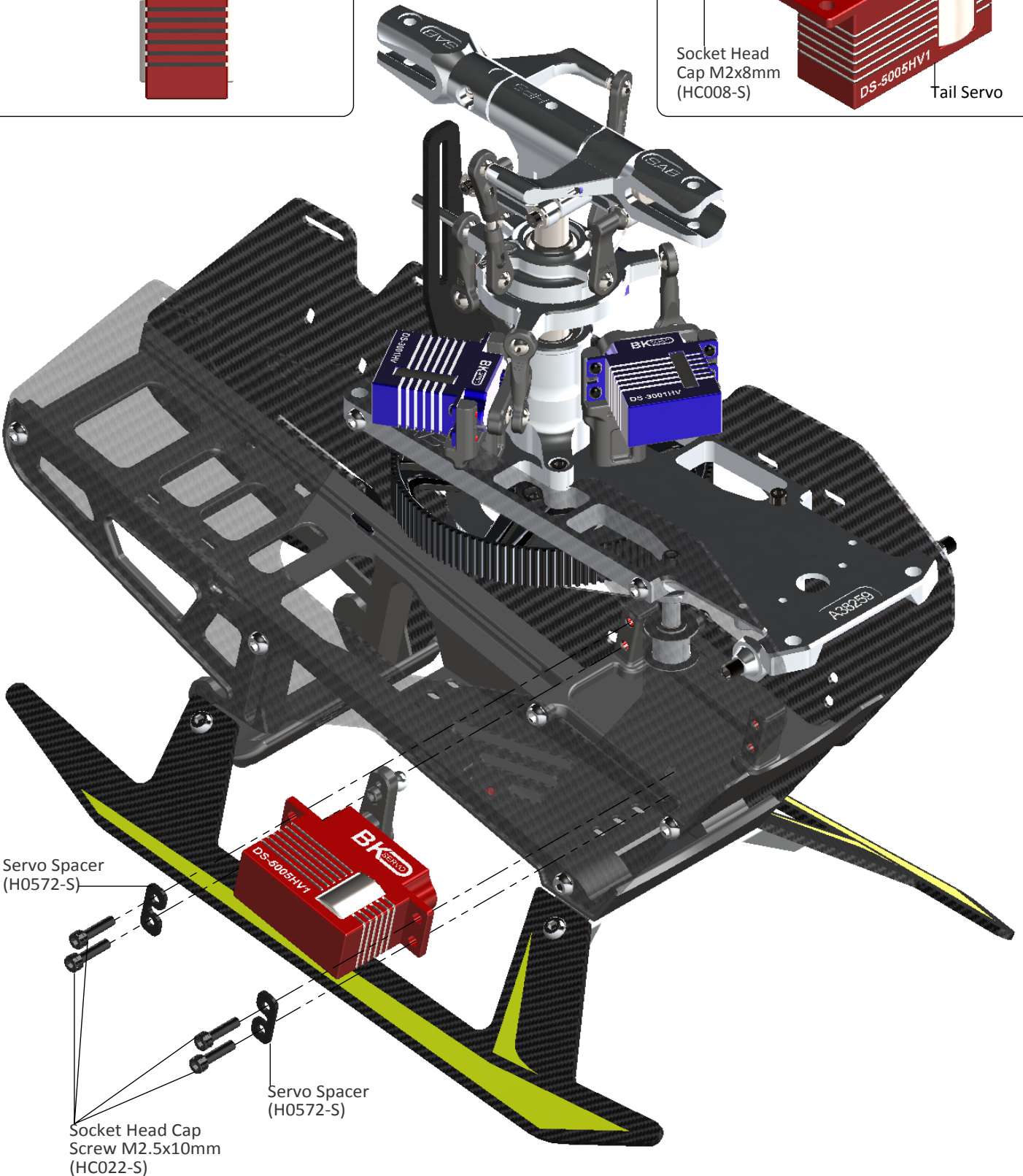
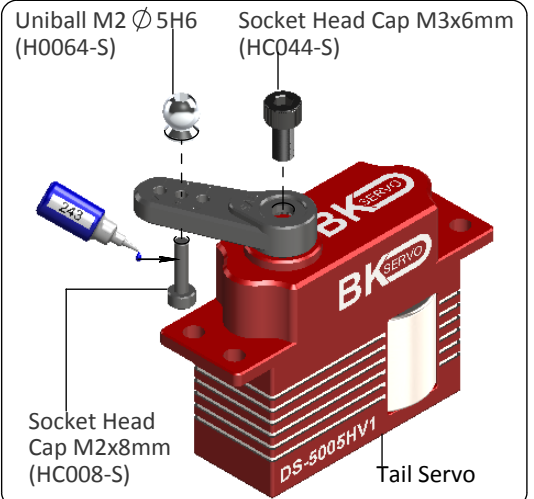

Servo Spacer
(H0572-S)

Servo Spacer
(H0572-S)

Socket Head Cap
Screw M2.5x10mm
(HC022-S)

TRANSMISSION SETUP

It is important to choose the right reduction ratio to maximize efficiency based on your required flight performance. It is possible to optimize any motor and battery combination. It is recommended to use wiring and connectors appropriate for the currents generated in a helicopter of this class.

If you are using a head speed calculator which requires a main gear and pinion tooth count, use **120** teeth for the main gear and the tooth count of your pulley as the pinion count.

Below is a list of available reduction ratios:

| | |
|---------------------------------------|---------------------------------------|
| H0501-19-S - 19T Pinion = ratio 6.3:1 | H0501-22-S - 22T Pinion = ratio 5.5:1 |
| H0501-20-S - 20T Pinion = ratio 6:1 | H0501-23-S - 23T Pinion = ratio 5.2:1 |
| H0501-21-S - 21T Pinion = ratio 5.7:1 | H0501-24-S - 24T Pinion = ratio 5:1 |

The Goblin 380 accepts a wide selection of batteries with different capacities. The suggested number of cells is 6.

All batteries from 1800 to 2600 mAh offer good performance.

Some example configurations:

CONFIGURATION

| Motor | ESC | Motor Pulley | RPM Max | Pitch |
|--|-------------------|--------------|-----------|-------|
| X-NOVA 2820-890 | CC Lite 100 | 21T | 3100 | ±12.5 |
| | HW 80 - HW 100 | 20T | 3100 | |
| | Jive 80 - YGE 100 | 19T | 3100 | |
| Scorpion HK 3020-1000 | CC Lite 100 | 20T-21T | 3100-3250 | ±12.5 |
| | HW 80 - HW 100 | 19T-20T | 3200-3350 | |
| | Jive 80 - YGE 90 | 18T-19T | 3250-3400 | |
| KDE 500XF 925-G3 Kontronik Pyro 380-9 X-NOVA 3215-930 | CC Lite 100 | 22T-23T | 3100-3250 | ±12.5 |
| | HW 80 - HW 100 | 21T-22T | 3250-3400 | |
| | Jive 80 - YGE 90 | 20T-21T | 3250-3400 | |



Note: For safety reasons we suggest to not exceed 3400 RPM.

Motor Pulley 20T
(H0501-20-S)

(see page 14 for optional pulleys)

Cone Point Set
Screws M3x6mm
(HC144-S)

Flat Head Socket
Cap M3x5mm
(HC132-S)

Motor Support
(H0520-S)

Motor

NOTE:

Correct position for the motor wires.

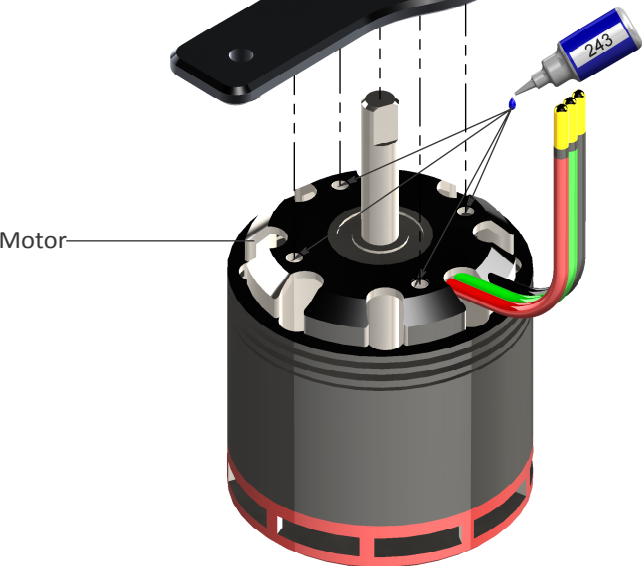
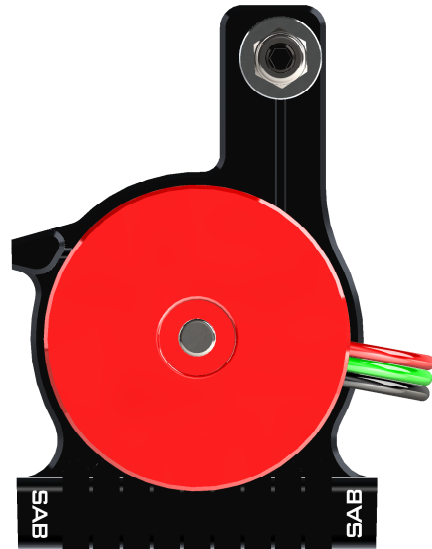

Socket Head Cap
Screws M2.5x8mm
(HC020-S)

Finishing Washer M2.5
(H0255-S)

Socket Head Cap
Screws M2.5x8mm
(HC020-S)

Metrix Hex
Nylon Nut M4
(HC212-S)

Washer
Ø 4.3x Ø 11x1mm
(HC184-S)

Cone Point Set
Screws M4x12mm
(HC156-S)

Finishing Washer M2.5
(H0255-S)

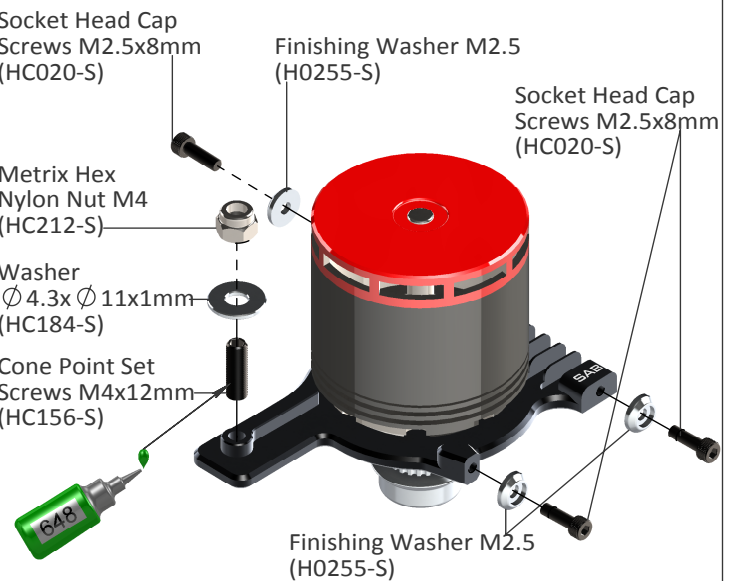

NOTE:

To maximize space for the batteries, it is advisable to shorten the motor shaft.

Follow the dimensions given in this drawing. Shaft have to be 22mm.

For the cut, you can use an electric tool like a "Dremel" with a cutoff disc.

Additionally, ensure the motor shaft has an appropriate 'flat' for one of the set screws.

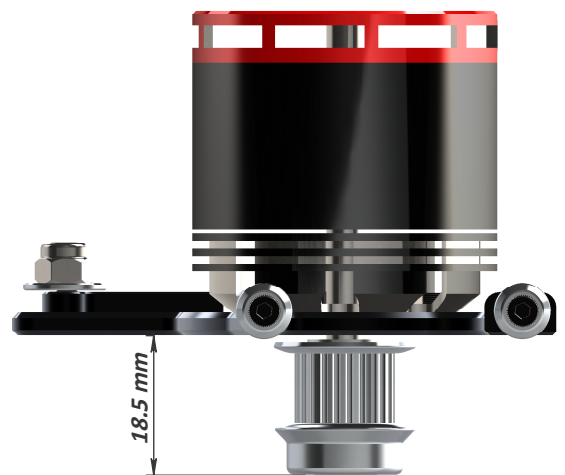
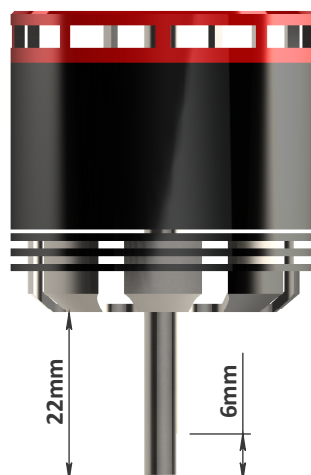

MOTOR BELT TENSION

- *Assemble the motor and pulley to its mounting plate.
- *Install the motor assembly in the helicopter.
- *It is easy to install the belt with the motor assembly pushed back towards the helicopter as far as it can go.
First put the belt on the motor pulley.
- *Then put the belt around the big pulley.
- *Rotate the motor several times by hand.
- *Pull and hold the motor slightly.
- *Tighten the M4 nut first (It is suggested to use tool nut driver).
- ***The belt must be very tight.**
- *Tighten the rest of the bolts.

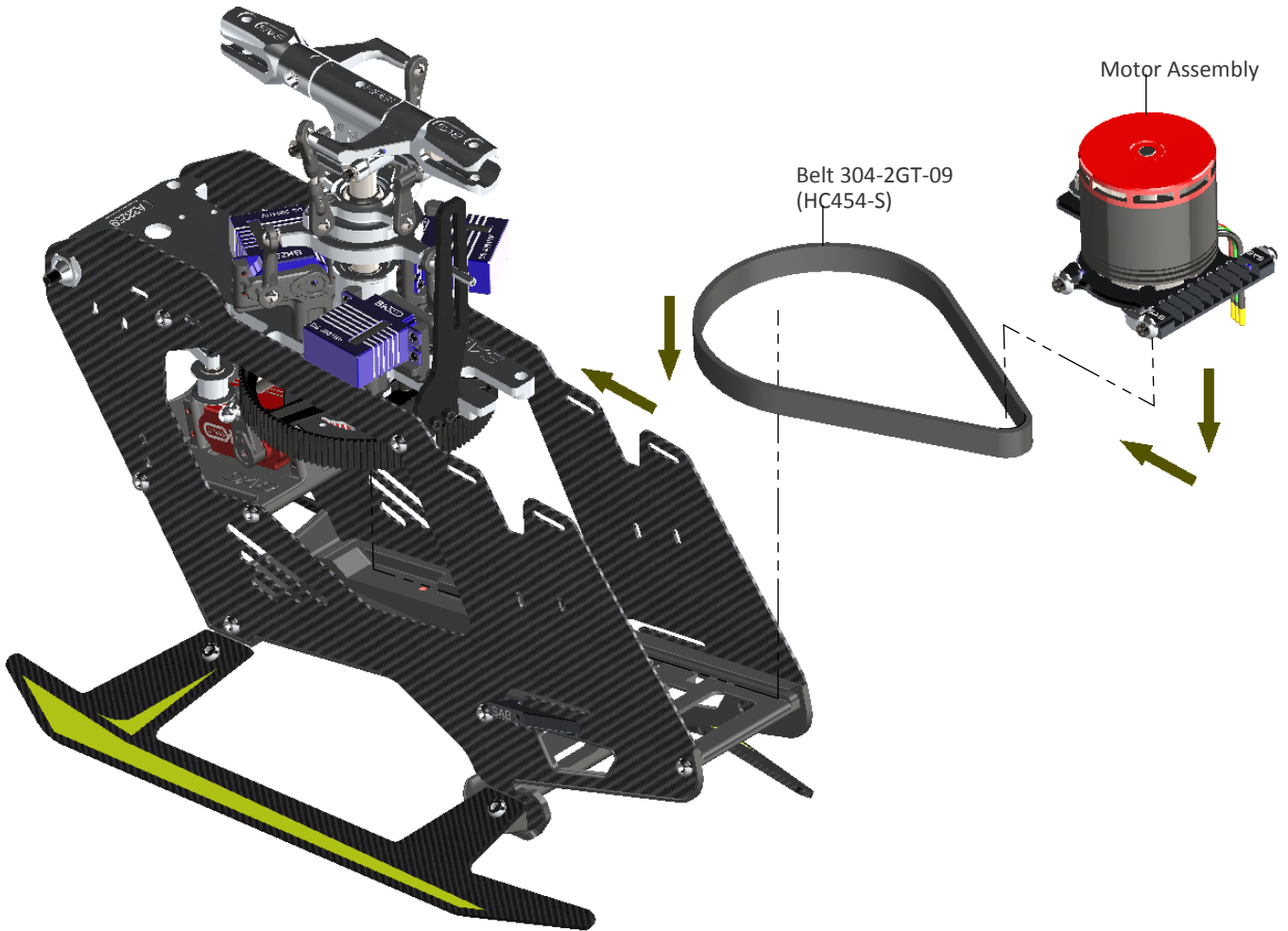

Note:

Check for vertical alignment of the motor pulley. To do this, simply turn the motor several times by hand and check to you see if the belt is aligned properly with the big pulley (one way bearing pulley).

If the belt is riding too high, simply loosen up the motor pulley and drop it just a little bit, if it is riding too low, loosen up the motor pulley and raise it a bit.

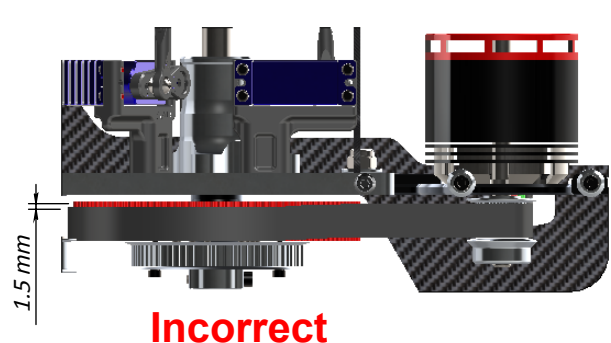
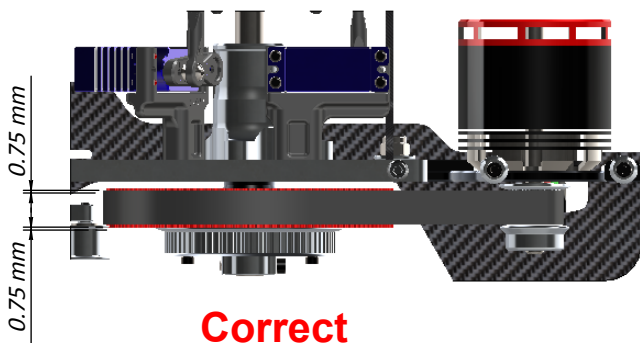

DE-BURR THE SIDE FRAMES

We recommend de-burring the edges of the carbon parts in areas where electrical wires run. (See Page 4).



ESC INSTALLATION

The speed controller (ESC) is installed in the front of the helicopter. **Figure 1** and **Figure 2** show the mounting area.

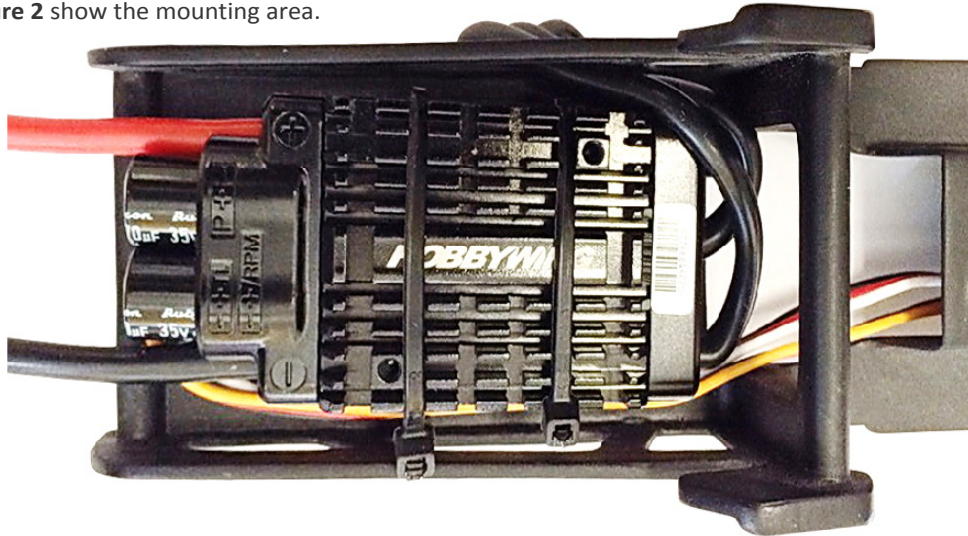

Fig. 1

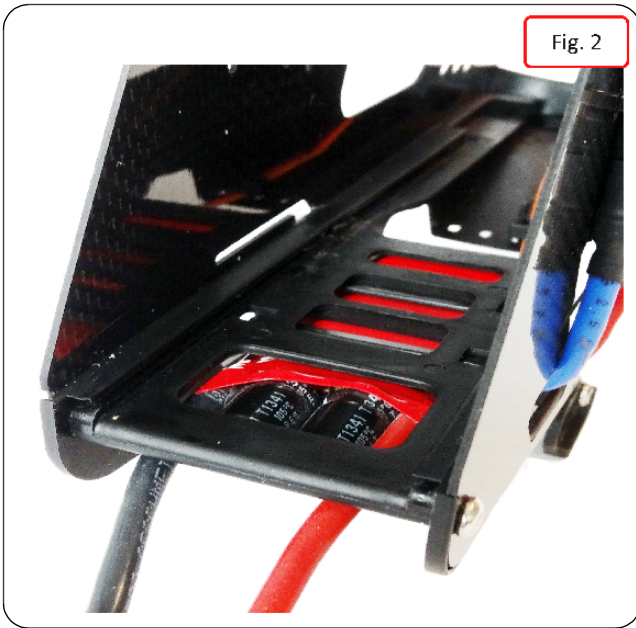

Fig. 2

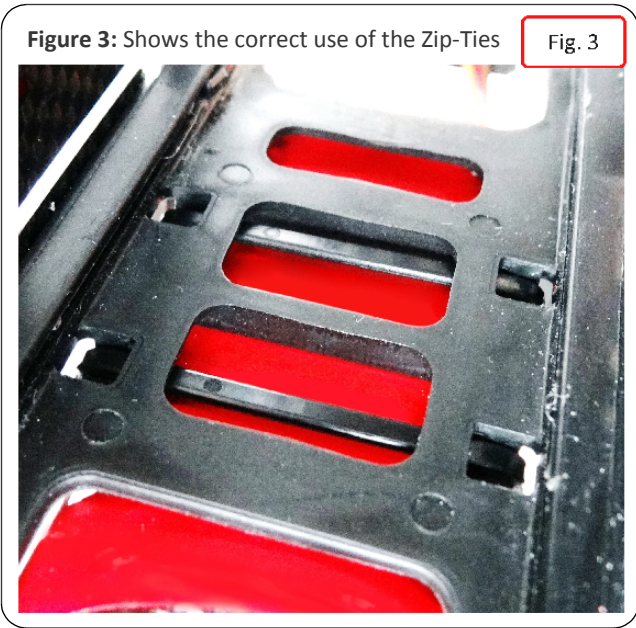

Figure 3: Shows the correct use of the Zip-Ties

Fig. 3

Figure 4: Shows the suggested length of the battery wire. This length is also compatible with the quick battery connector upgrade.

Figure 5: Shows the wire that connects the ESC to the receiver or flybarless control system.

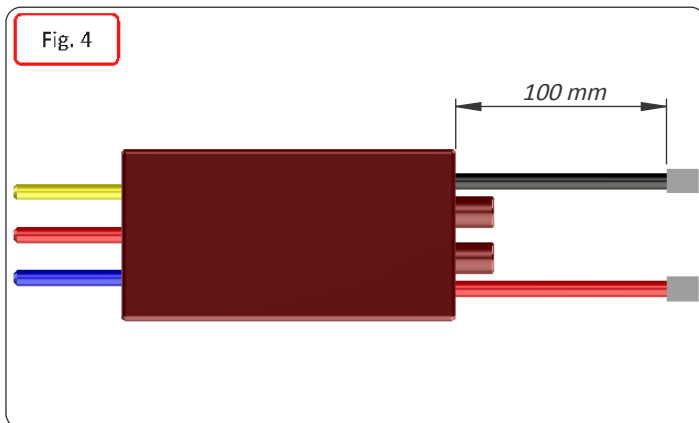

Fig. 4

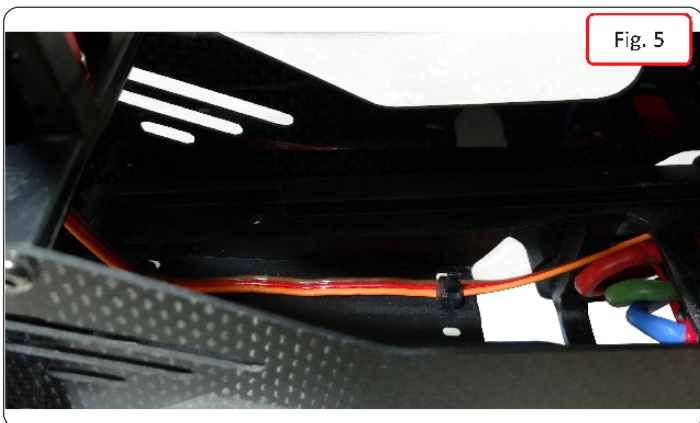

Fig. 5

FLYBARLESS CONTROL UNIT AND RX INSTALLATION

We suggest the use of a “single unit” FBL system (all in one type unit). This allows for easier wire routing considering the small size of this helicopter.

Position 1 can be used to install the FBL unit.

Position 2 and 3 can be used to install a small RX unit, like a Spektrum satellite.

Position 4 and 5 can be used to install RX unit.

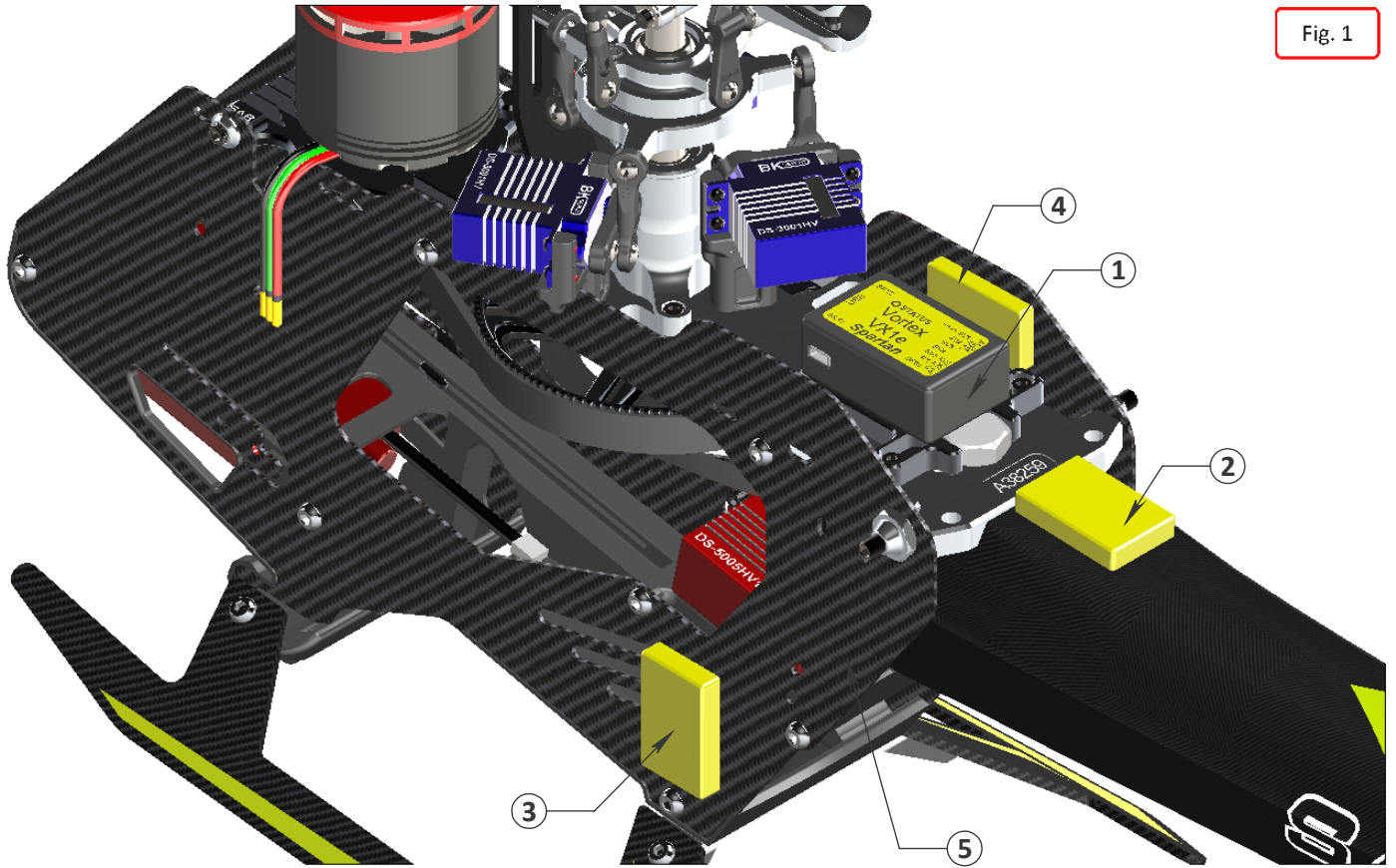

Fig. 1

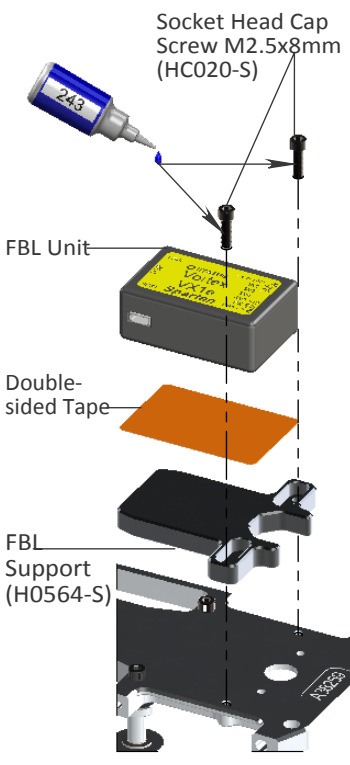

Fig. 2 shows the unit mounted on the support H0564. Fig. 3 shows the unit directly mounted on the main aluminum plate.

Use your judgment to decide whether you need to install your FBL unit as shown in Fig 2 or Fig 3. This will depend on the size of the FBL unit itself and the arrangement of the wires.

With larger units, the nylon nut can make it difficult to connect the wires to the unit, in this case it is recommended to use the aluminum support H0564.

With smaller units, the unit can be installed directly onto the main plate. This facilitates boom removal in the future if necessary.

We recommend using some type of adhesive to prevent the servo wires and connections from coming unplugged from the receiver or FBL unit. You can use hot glue for this purpose.

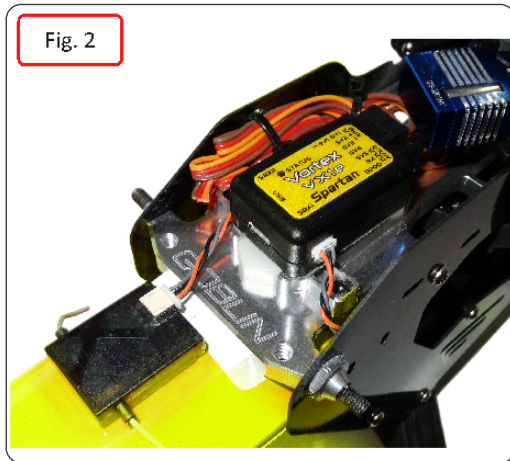

Fig. 2

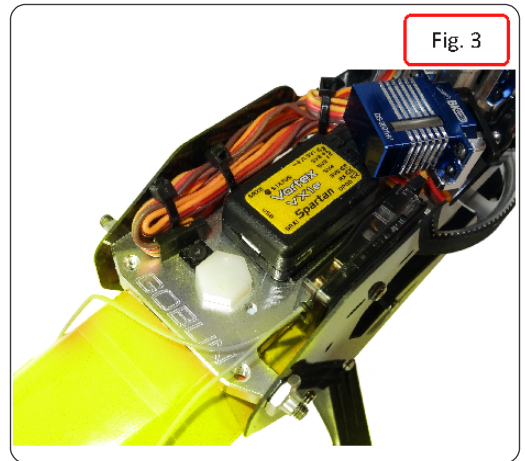
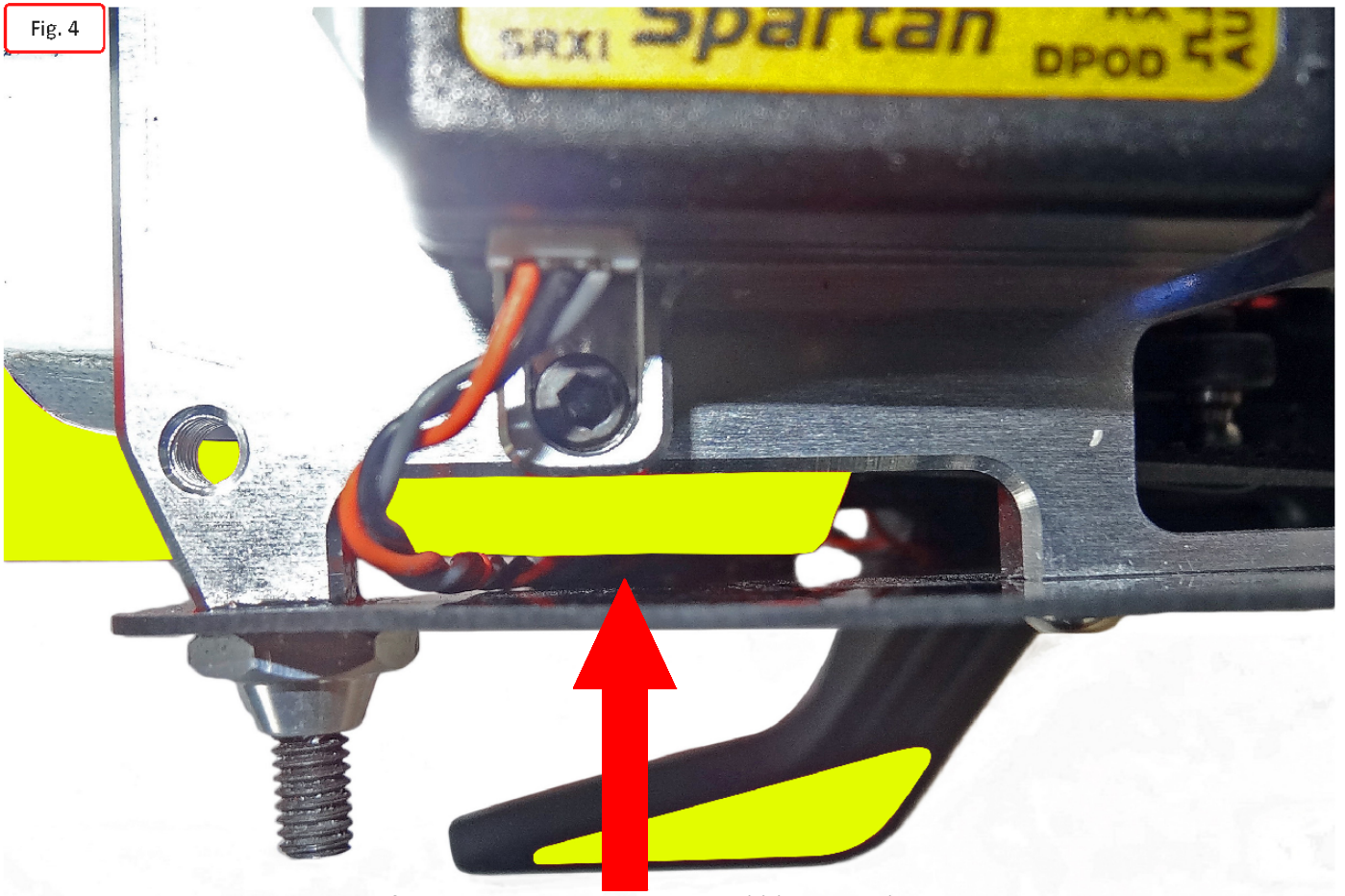

Fig. 3

Fig. 4



The area between the boom and the frame can be used to route the wire(s) (Fig 4 and 5).

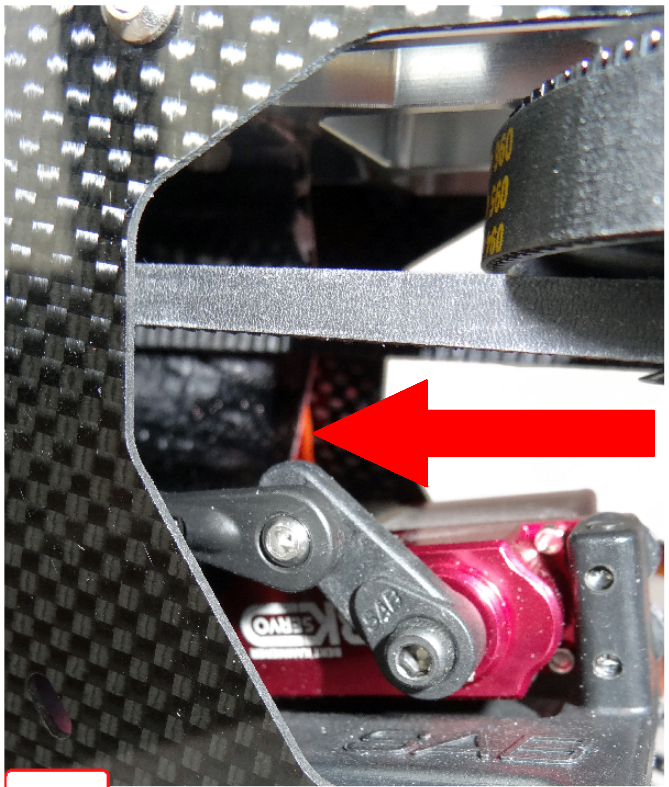

Fig. 5

You can secure the wire(s) to the frame with zip-ties (Fig6).

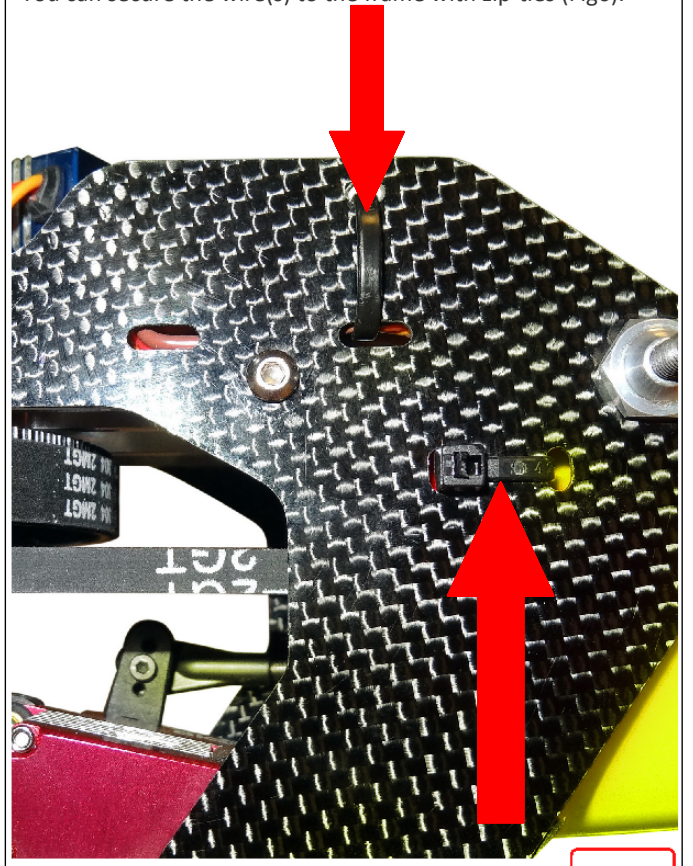
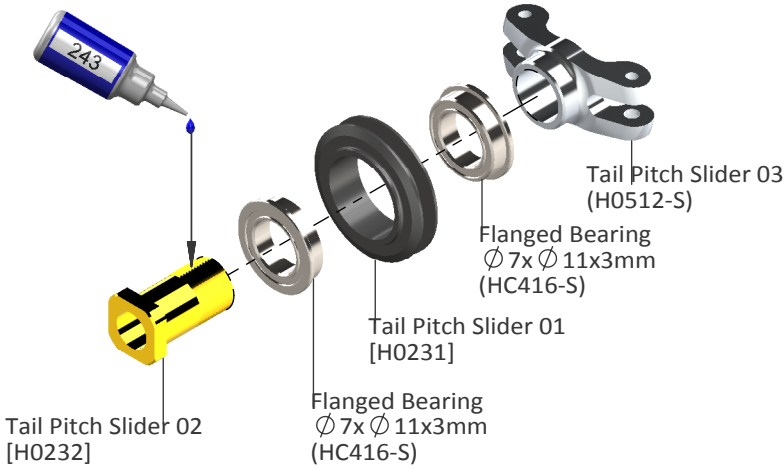

Fig. 6



Tail Pitch Slider Assembly

Already Assembled



Tail Rotor Hub Assembly

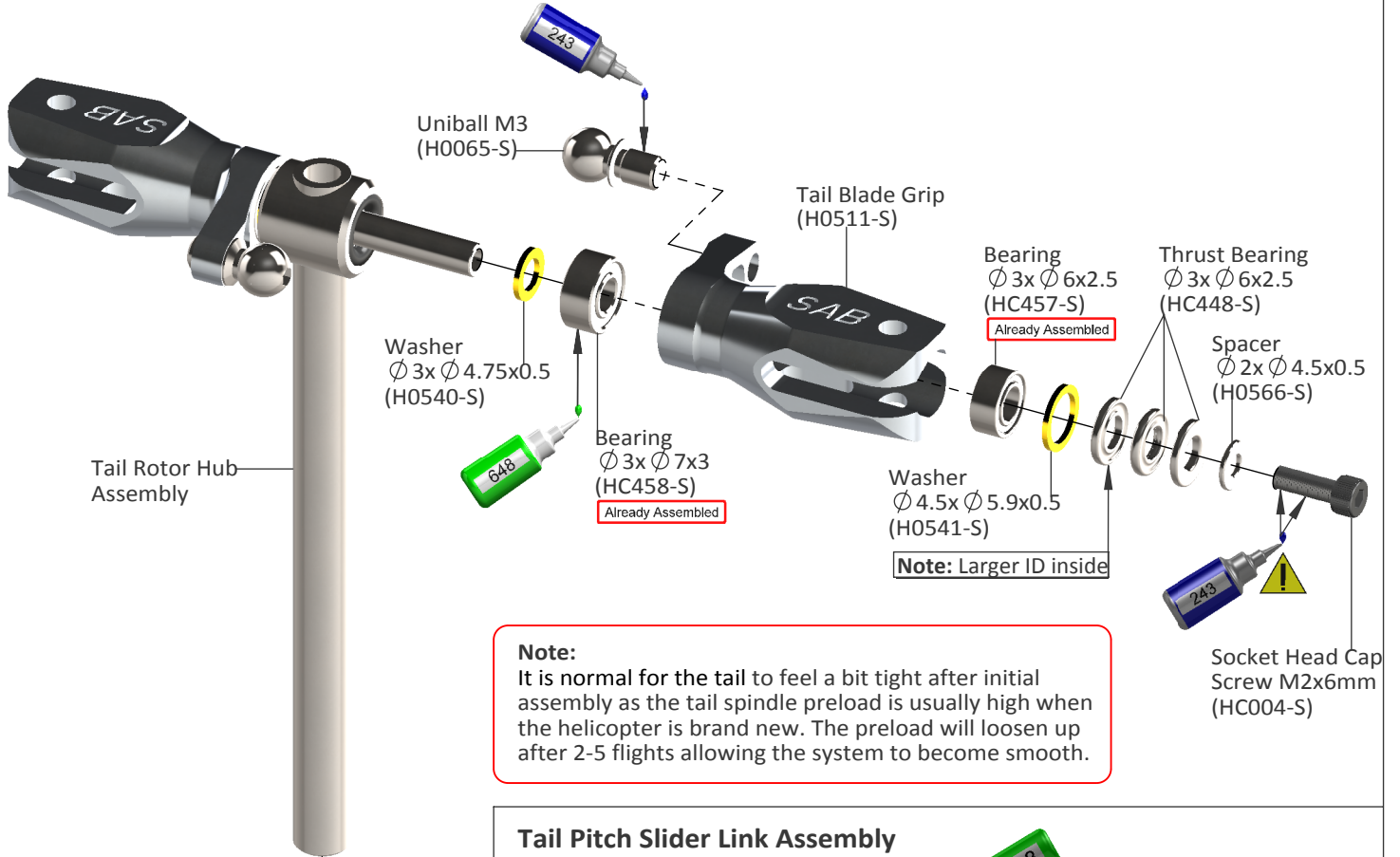
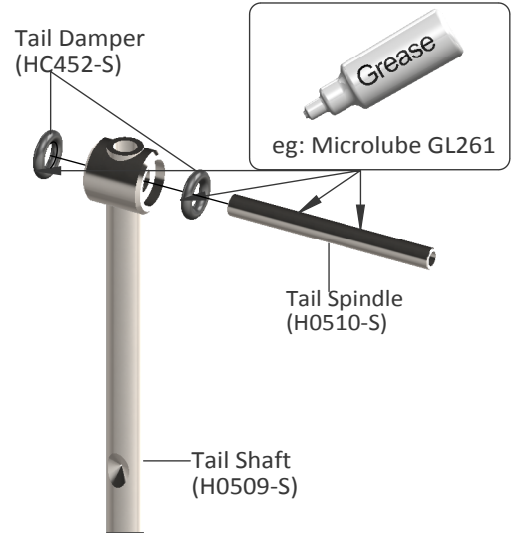

Note:
It is normal for the tail to feel a bit tight after initial assembly as the tail spindle preload is usually high when the helicopter is brand new. The preload will loosen up after 2-5 flights allowing the system to become smooth.



Tail Pitch Slider Link Assembly

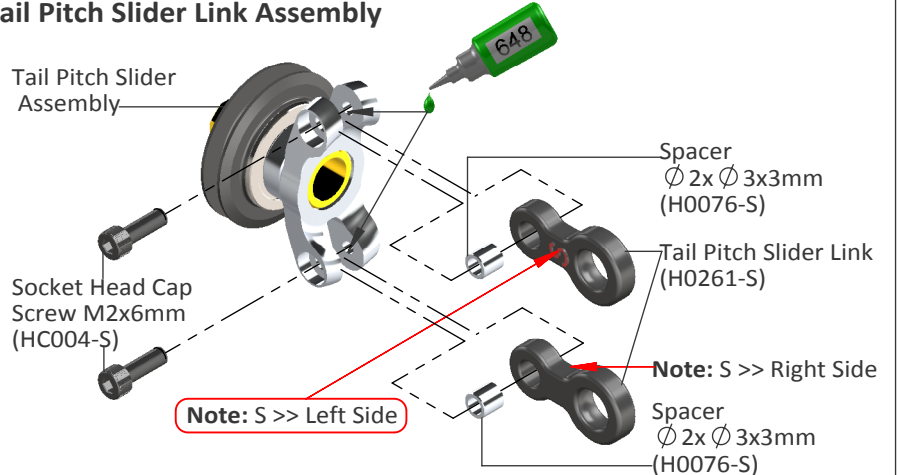

Tail Side Plate Assembly

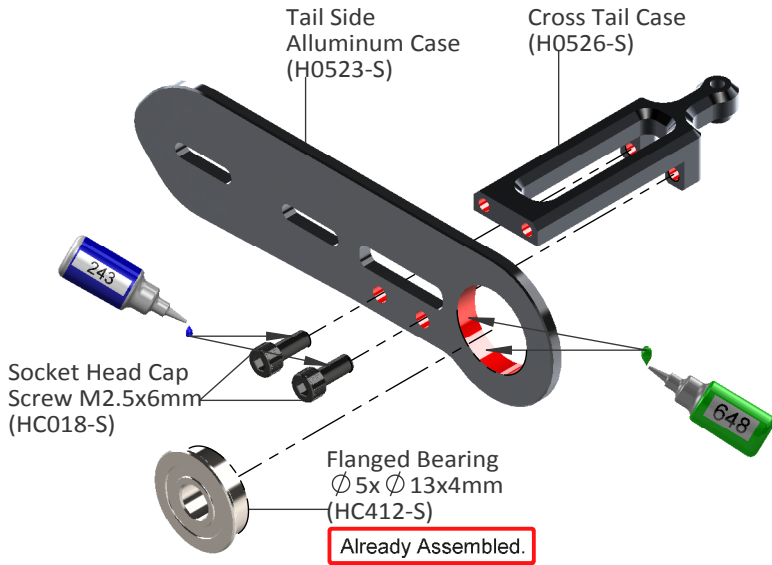

Bell Crank Lever Assembly

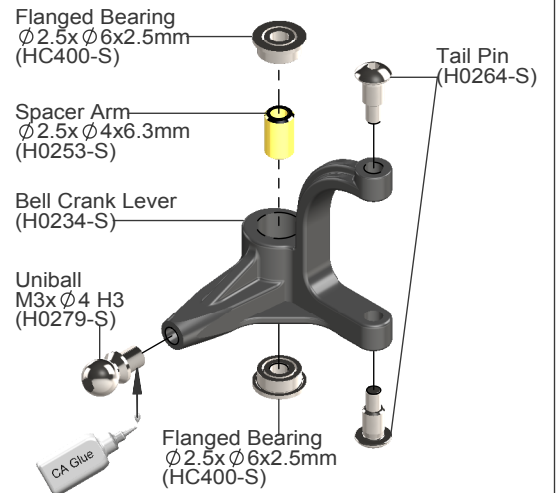

Tail System Assembly

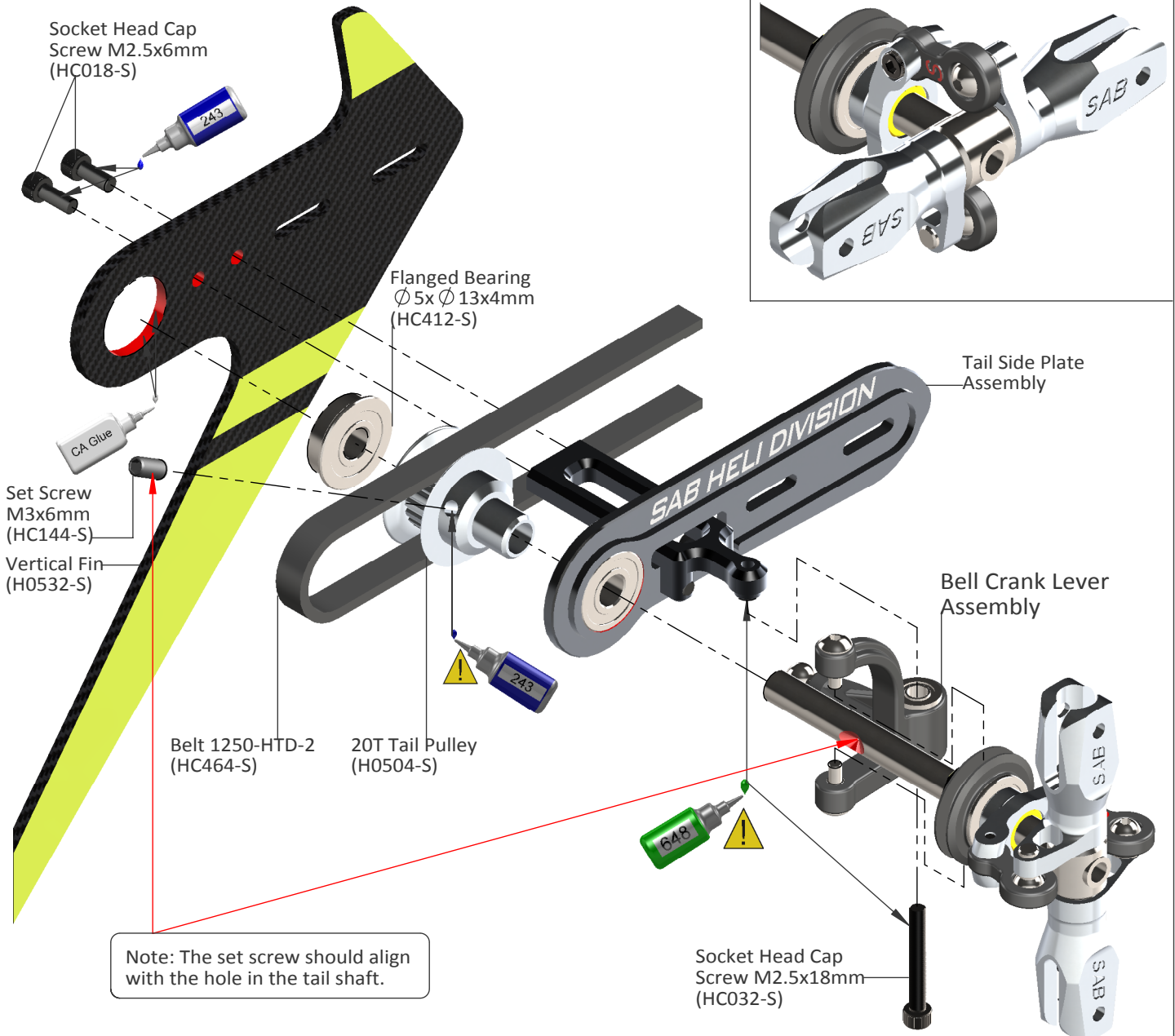

Note: We suggest to clean the sticking surface with sand paper.

Locking Element Tail Assembly x 2

Locking Element Tail
(H0535-S)

Already Assembled



Metric Hex
Nylon Nut M2.5
(HC200-S)

Tail Boom Assembly

Yellow Tail Boom
(H0815-S)

Locking Element
Tail Assembly
(H0535-S)

Double
Sided Tape
(HA033-S)

Double
Sided Tape
(HA033-S)

M8 Carbon Block Assembly



Metrix Nylon
Nut M8
(HC224-S)

M8 Carbon Block
(H0534-S)

M8 Carbon Block
Assembly

Double Sided Tape
(HA034-S)

Yellow Tail Boom
(H0815-S)

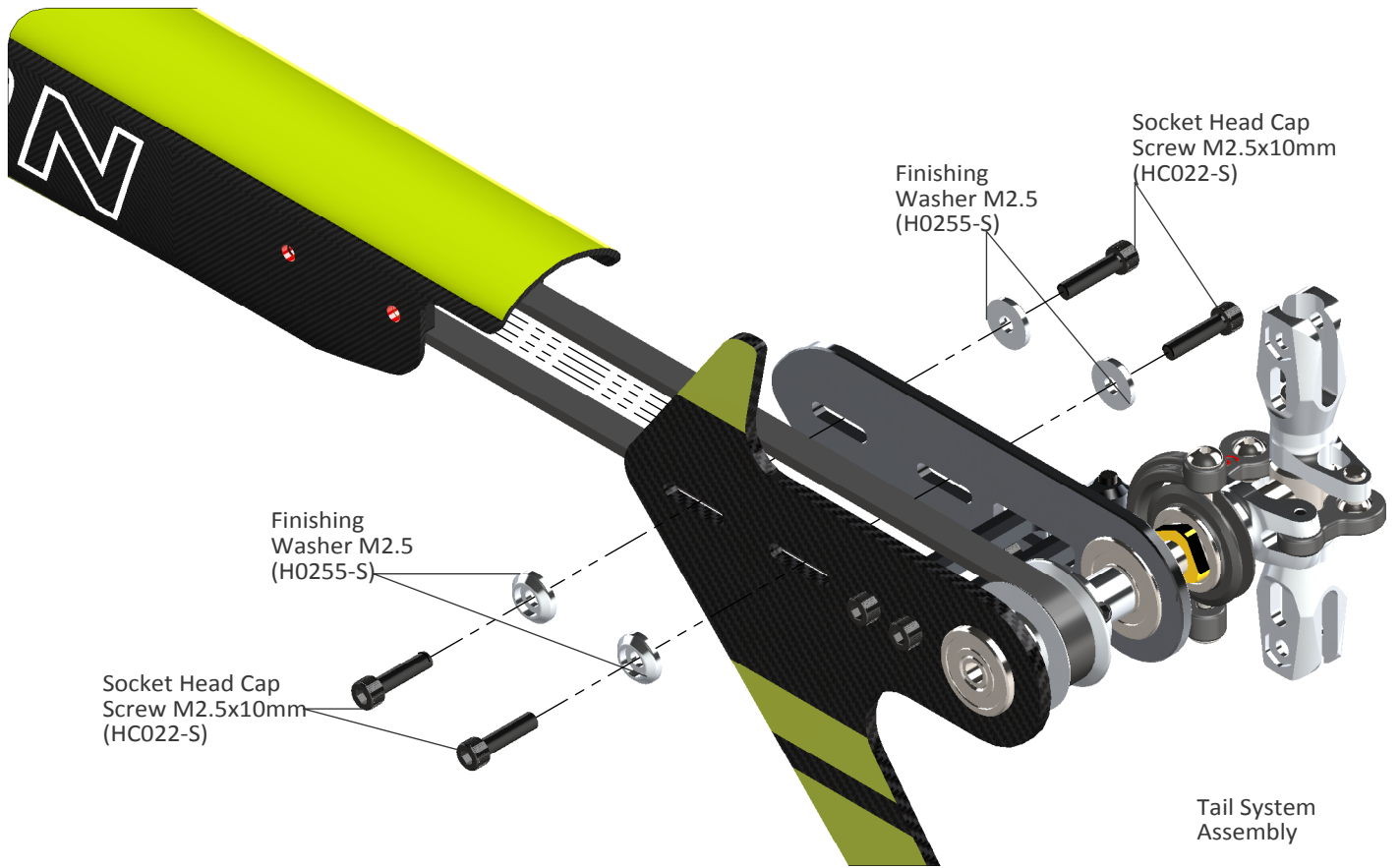

Note: Please allow plenty of time for the glue to cure before inserting plastic ball link onto the threaded rod.

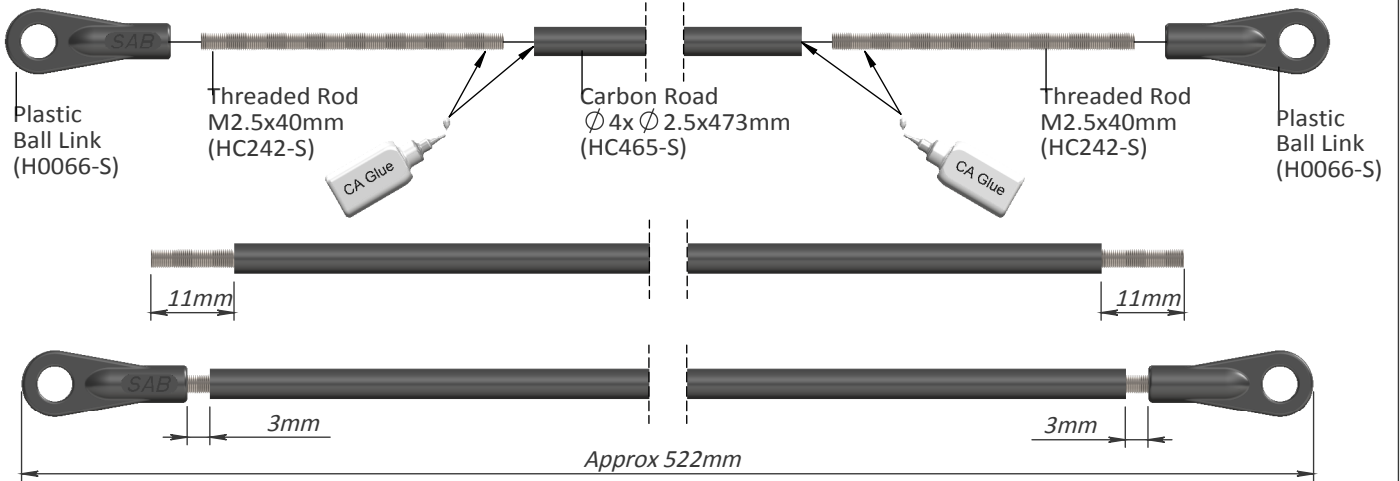

DETAIL A



BOOM ASSEMBLY

- * Insert the boom. This operation is easier fitting into the main frame at a slight angle [Fig.1].
- To facilitate boom insertion, you can also unscrew the two bolts that hold the tail servo support tray.
- * Tighten the M8 nut with HA016 special tool supplied.
- * After installation, connect the tail push rod.
- * To lock the nut and prevent it from coming loose, install:
 - H0287 (for FBL unit installed on the main plate) [Fig.2].
 - H0564 (for FBL unit installed on H0564) [Fig.3].

NOTE:

Fig. 1

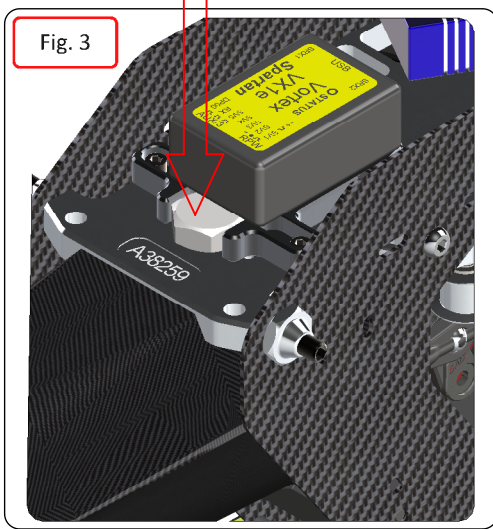
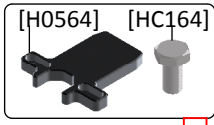
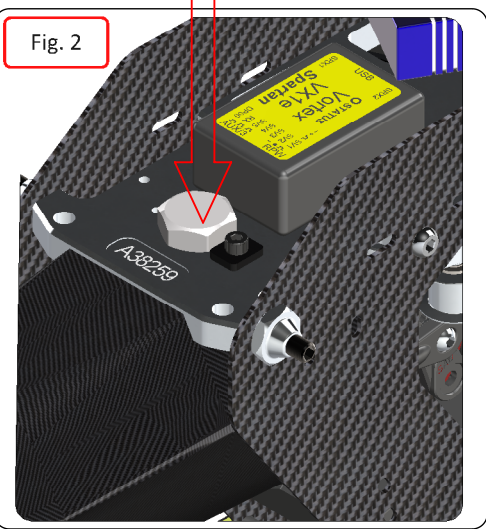
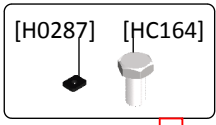
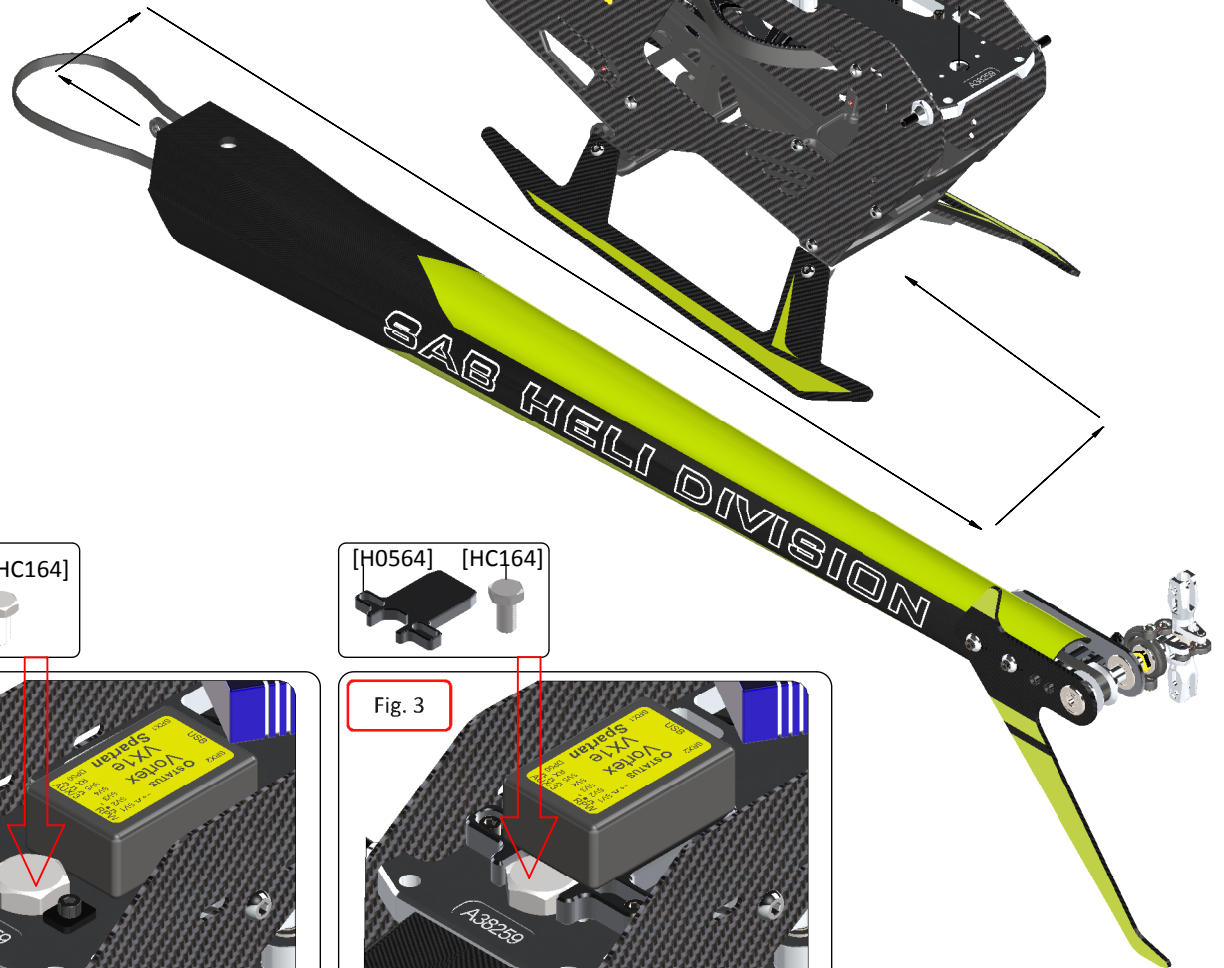
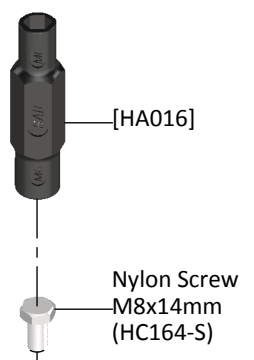
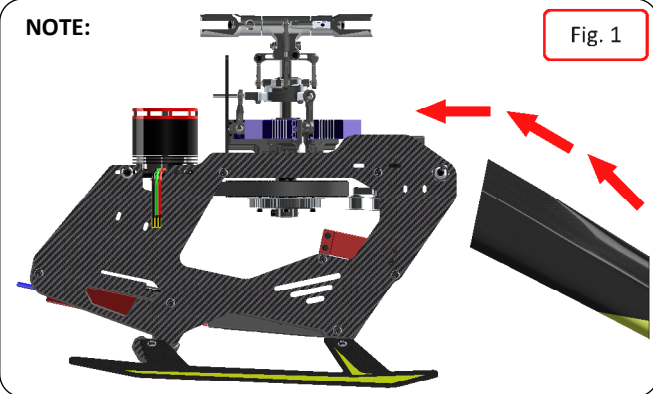

TAIL BELT TENSION

- *Check for the proper assembly of the tail boom.
- *Loosen the tail case by loosening the 4 M2.5 screws.
- *Install the belt onto the front pulley in the correct direction of rotation (figure 1).
- *Rotate the tail drive several times by hand.
- *Pull the tail case back to increase belt tension.
- *Tighten the 4 M2.5 screws on the tail case.
- *The belt must be very tight.

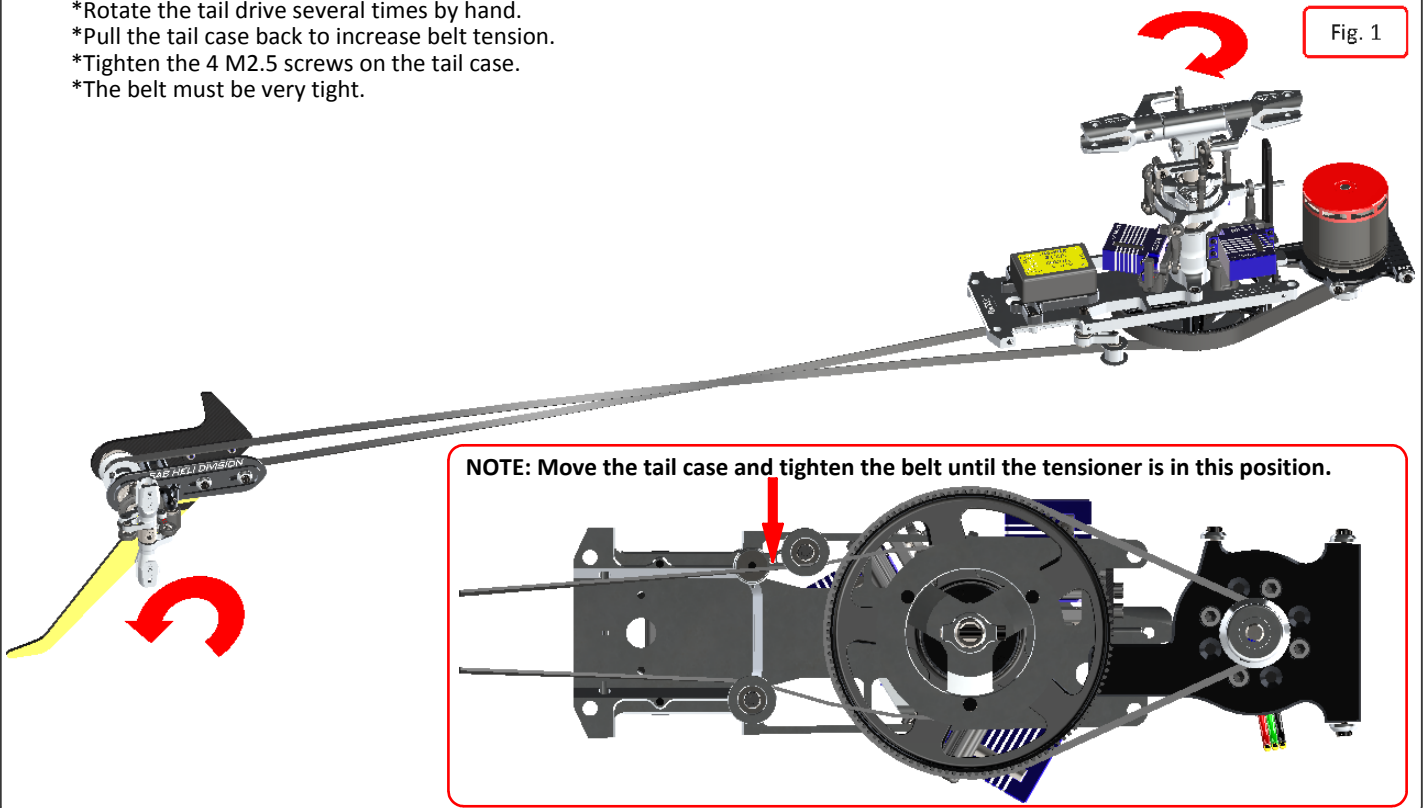

CANOPY

Fit the canopy to the main frame until it stops. [Fig. 2]
 Fit the canopy holes to the M4 set screws on the model.

Check alignment of the edge on the boom [Fig. 3]
 If the alignment is correct, enlarge the 2 canopy holes with a reamer up to 10 mm in diameter.
 If alignment is not OK, enlarge the 2 canopy holes in the appropriate direction up to 10 mm in diameter.

Install the canopy grommets. [Fig. 4]

The canopy can be locked using the knobs H0543. [Fig. 5]

NOTE: If you want to use the rubber edge protector, you must increase the size of the opening in the canopy that goes around the anti-rotation guide by approximately 2 mm per side.

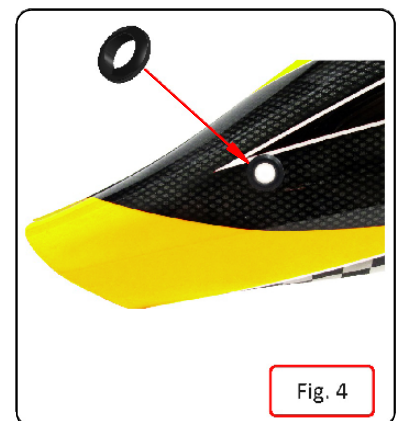
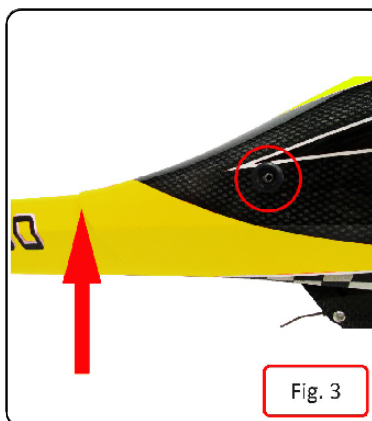
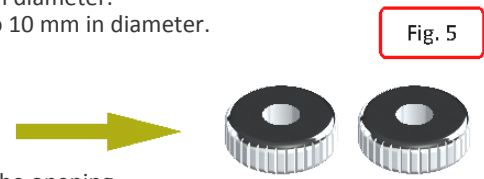

BATTERIES

The Goblin has a quick release battery tray system.

The batteries must be installed onto the battery tray to take advantage of the quick release locking system.

Install the battery to the battery tray using double sided tape and the long Velcro straps included (Fig 1 and Fig 2).

Make sure to find the right position of the battery to optimize the center of gravity.

The battery wires arranged as in fig 2 are particularly effective.

To insert the battery, simply align the battery tray in the slots at the front of the helicopter and slide all the way. The battery will lock in place.

To remove the battery, simply lift up on the locking lever (Fig 5) and pull.

IMPORTANT:



Make sure the battery is locked in place before flight; the battery tray must be inside the slots on both sides!

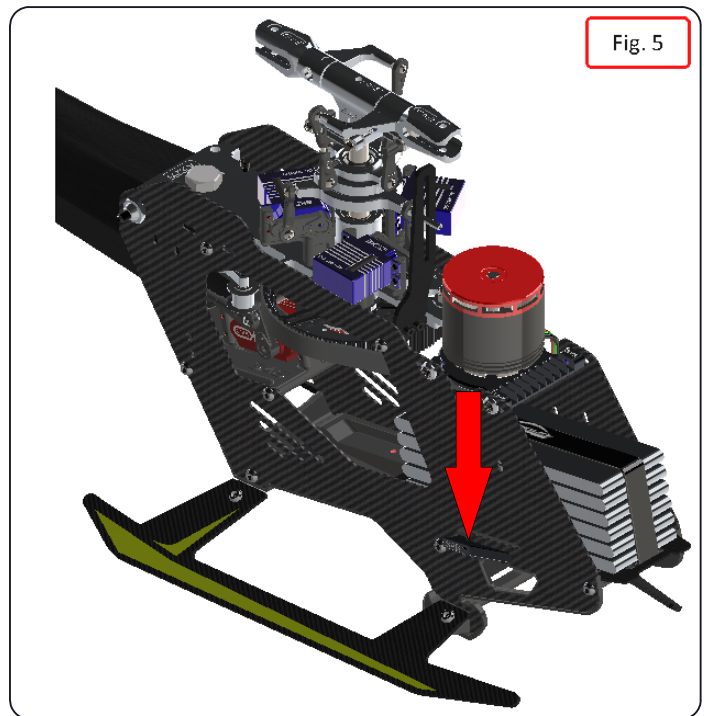
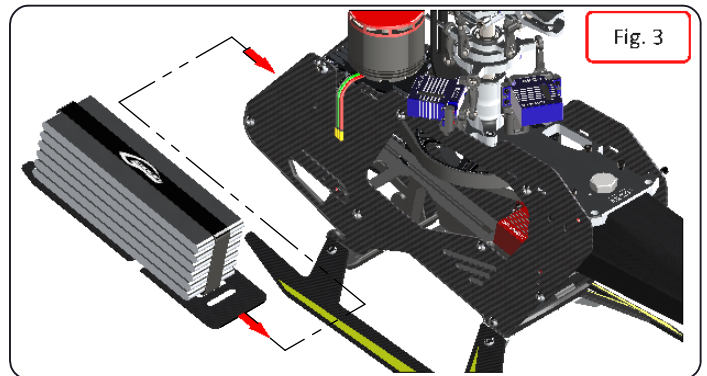
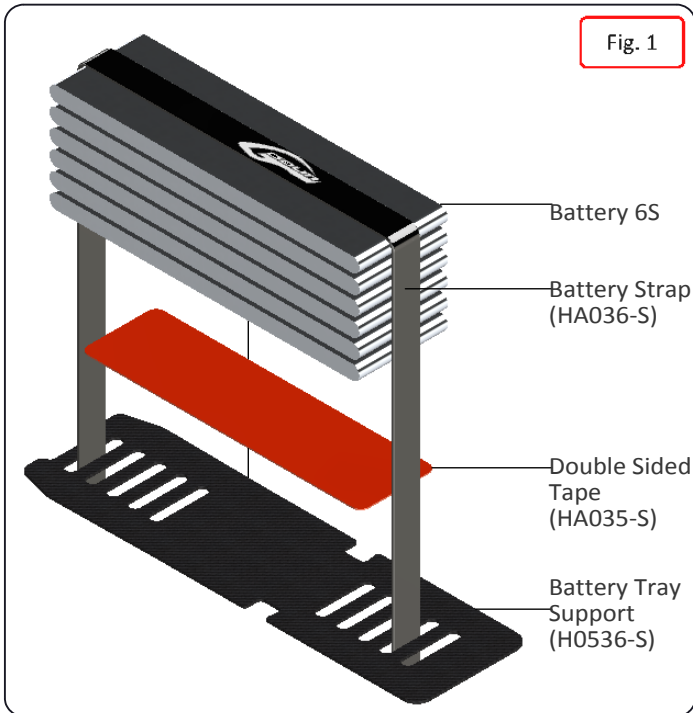

OPERATIONS BEFORE FLIGHT

*Set up the transmitter and the flybarless system with utmost care.

*It is advisable to test the correct settings of the transmitter and flybarless system without main blades and tail blades fitted.

*Check that all wiring is isolated from the carbon/aluminum parts. It is good practice to protect them at the points where they are at most risk.

⚠ *Be sure of the gear ratio, verifying carefully the motor pulley in use. The forces acting on the mechanics increase enormously at higher RPM. For safety reasons we suggest to not exceed 3400 RPM.

*Fit the main blades and tail blades. (Fig.1 and Fig.2)

*Please make sure the main blades are tight on the blade grips, you should be able to violently jerk the head in both directions and the blades should not fold. Failure to tighten the blades properly can result in a boom strike during spool up. To fold the blades for storage, it is advisable to loosen them.

*Check the collective and cyclic pitch. For 3D flight, set about +/- 12.5°.

*It is important to check the correct tracking of the main blades. (Fig 3).

⚠ *Perform the first flight at a low head speed, 2200/2300 RPM.
After this first flight, do a general check of the helicopter. Verify that all screws and bolts are correctly tightened.

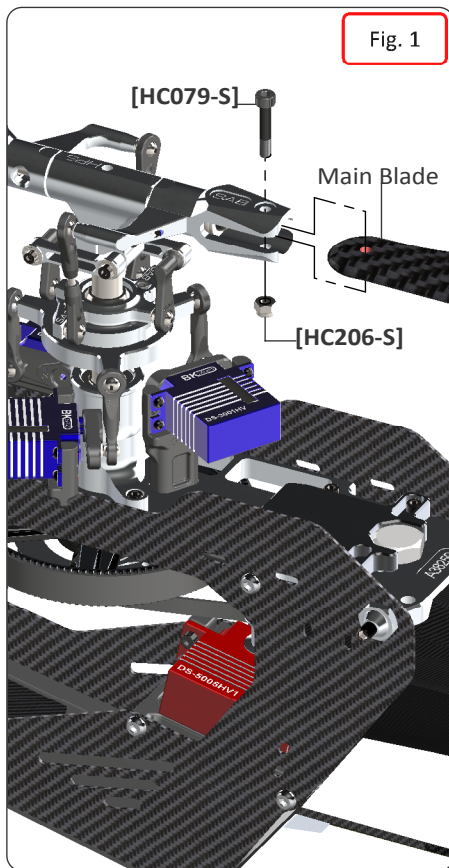

Fig. 1

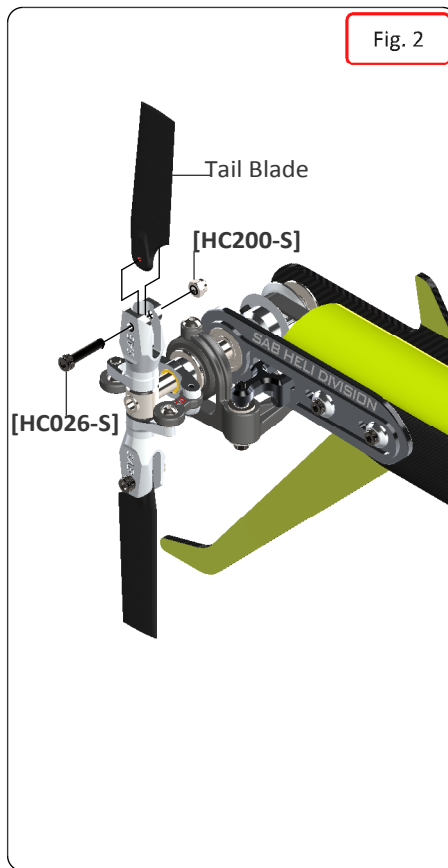

Fig. 2

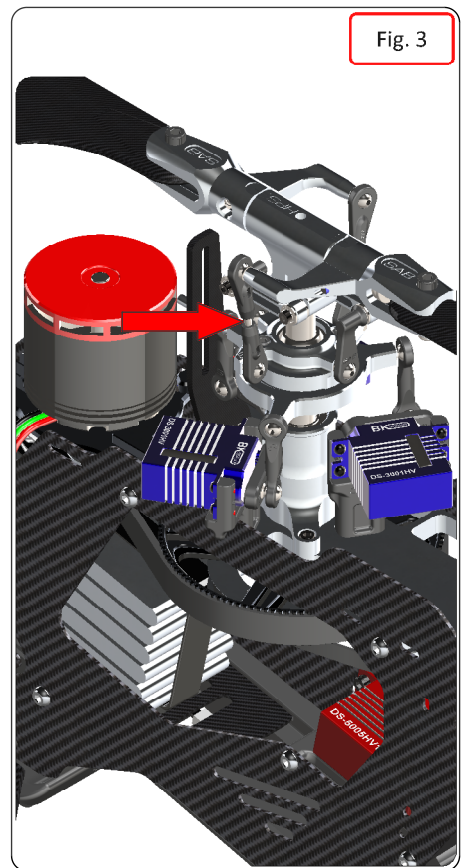

Fig. 3

IN FLIGHT

It's very important to check the model thoroughly after the first 2-3 flights. Check all bolts, screws, belts, ball links, etc.

If the model is making strange noises, this can be usually attributed to incorrect belt tensions. Check the belts again and tighten if necessary.

MAINTENANCE

*On the Goblin 420, some areas to look for wear include:

- Motor belt
- Tail belt
- Dampers

*The most stressed bearings are definitely those on the tail shaft and the thrust bearings. Check them frequently. All other parts are not particularly subject to wear.

Fig. 1

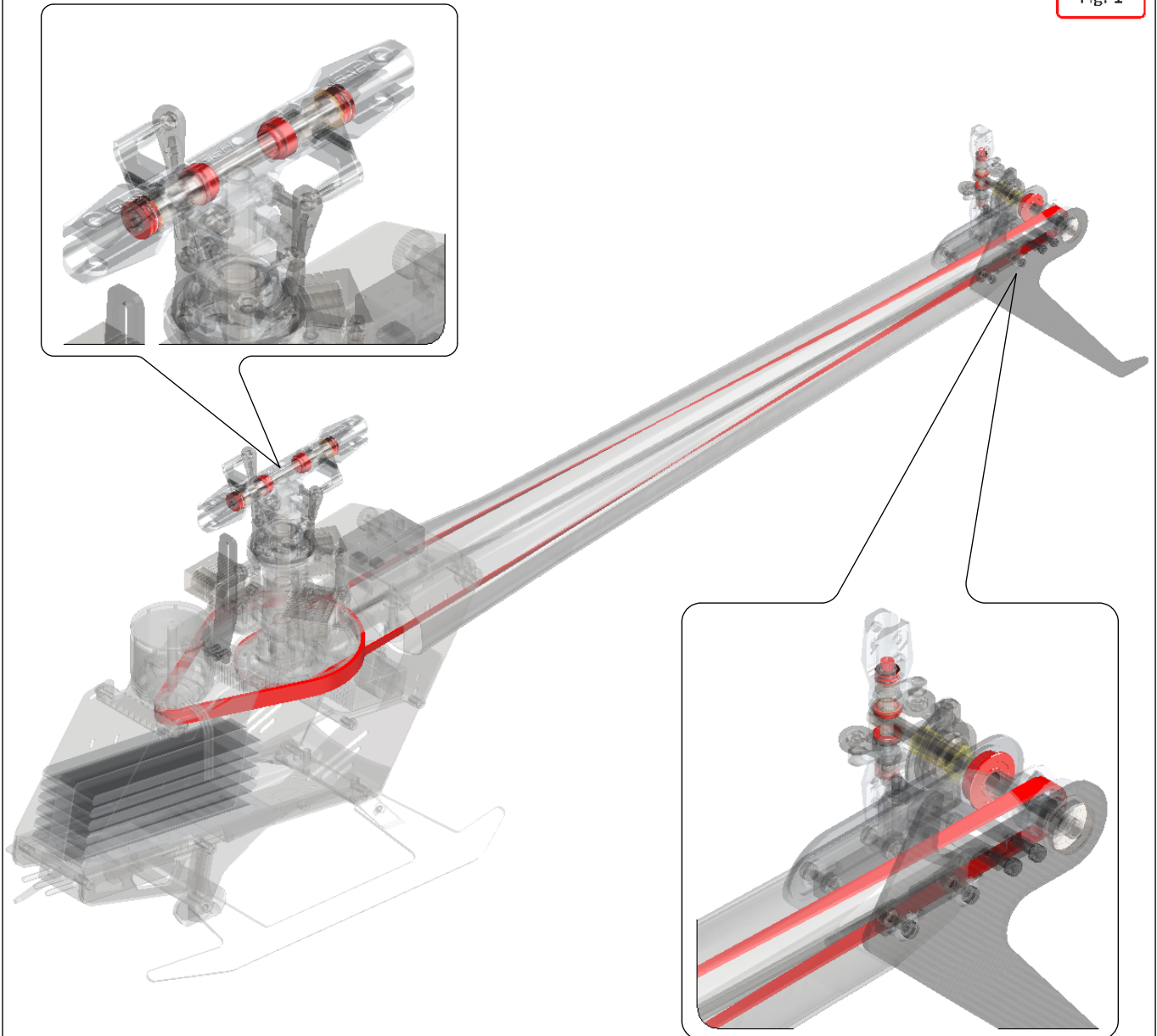

*The lifespan of these components varies according to the type of flying. On average it is recommended to check these parts every **20** flights. In some instances, based on wear, these parts should be replaced every **100** flights.

*Periodically lubricate the tail slider movement and its linkages as well as the swash plate movement and its linkages.

*To ensure safety you should do a general inspection of the helicopter after each flight. You should check:

- Proper belt tension (motor belt and tail belt).
- Proper isolation of the wires from the carbon and aluminum parts.
- All screws and bolts remain tight.

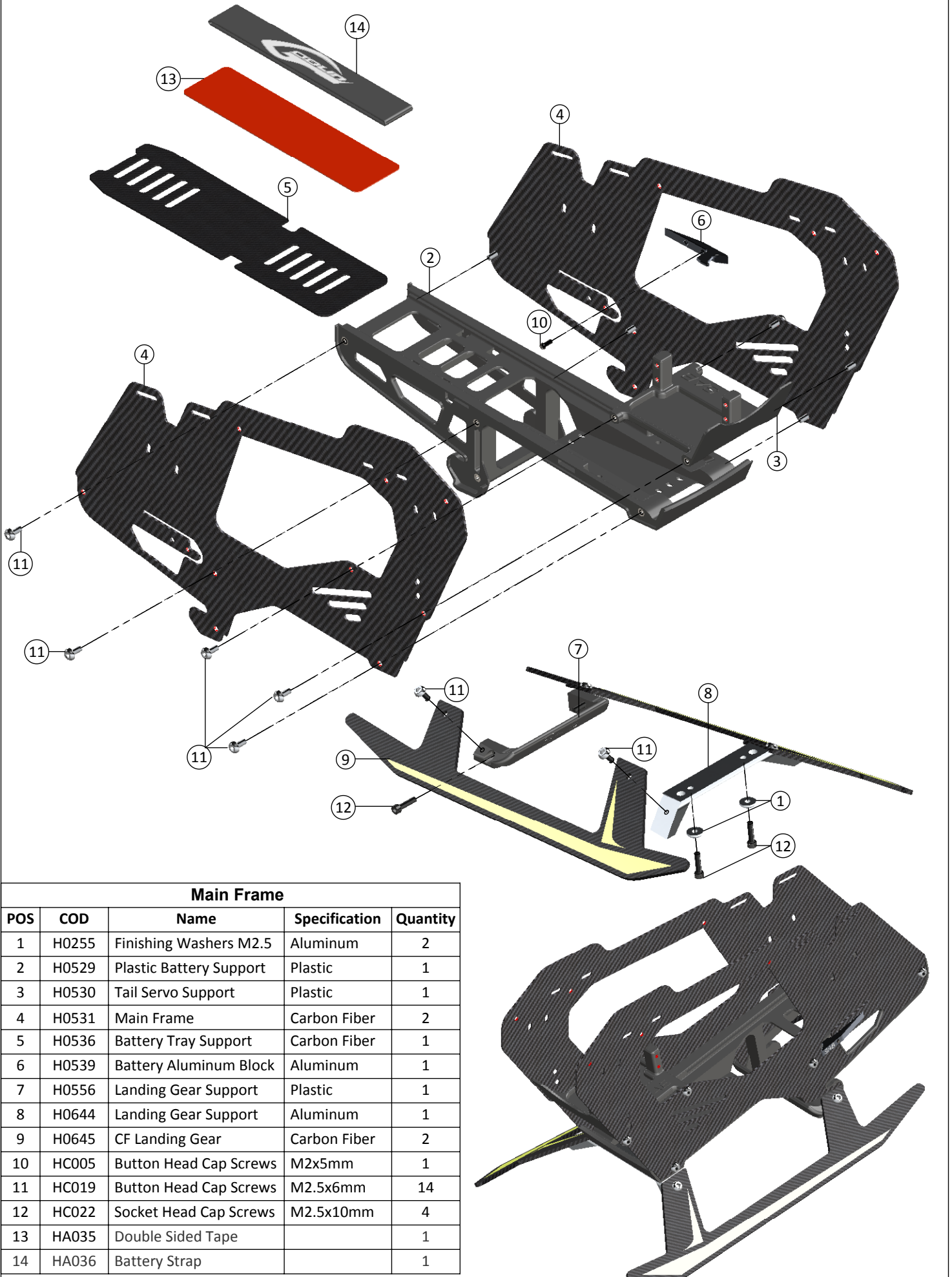

| Main Frame | | | | |
|------------|-------|-------------------------|---------------|----------|
| POS | COD | Name | Specification | Quantity |
| 1 | H0255 | Finishing Washers M2.5 | Aluminum | 2 |
| 2 | H0529 | Plastic Battery Support | Plastic | 1 |
| 3 | H0530 | Tail Servo Support | Plastic | 1 |
| 4 | H0531 | Main Frame | Carbon Fiber | 2 |
| 5 | H0536 | Battery Tray Support | Carbon Fiber | 1 |
| 6 | H0539 | Battery Aluminum Block | Aluminum | 1 |
| 7 | H0556 | Landing Gear Support | Plastic | 1 |
| 8 | H0644 | Landing Gear Support | Aluminum | 1 |
| 9 | H0645 | CF Landing Gear | Carbon Fiber | 2 |
| 10 | HC005 | Button Head Cap Screws | M2x5mm | 1 |
| 11 | HC019 | Button Head Cap Screws | M2.5x6mm | 14 |
| 12 | HC022 | Socket Head Cap Screws | M2.5x10mm | 4 |
| 13 | HA035 | Double Sided Tape | | 1 |
| 14 | HA036 | Battery Strap | | 1 |

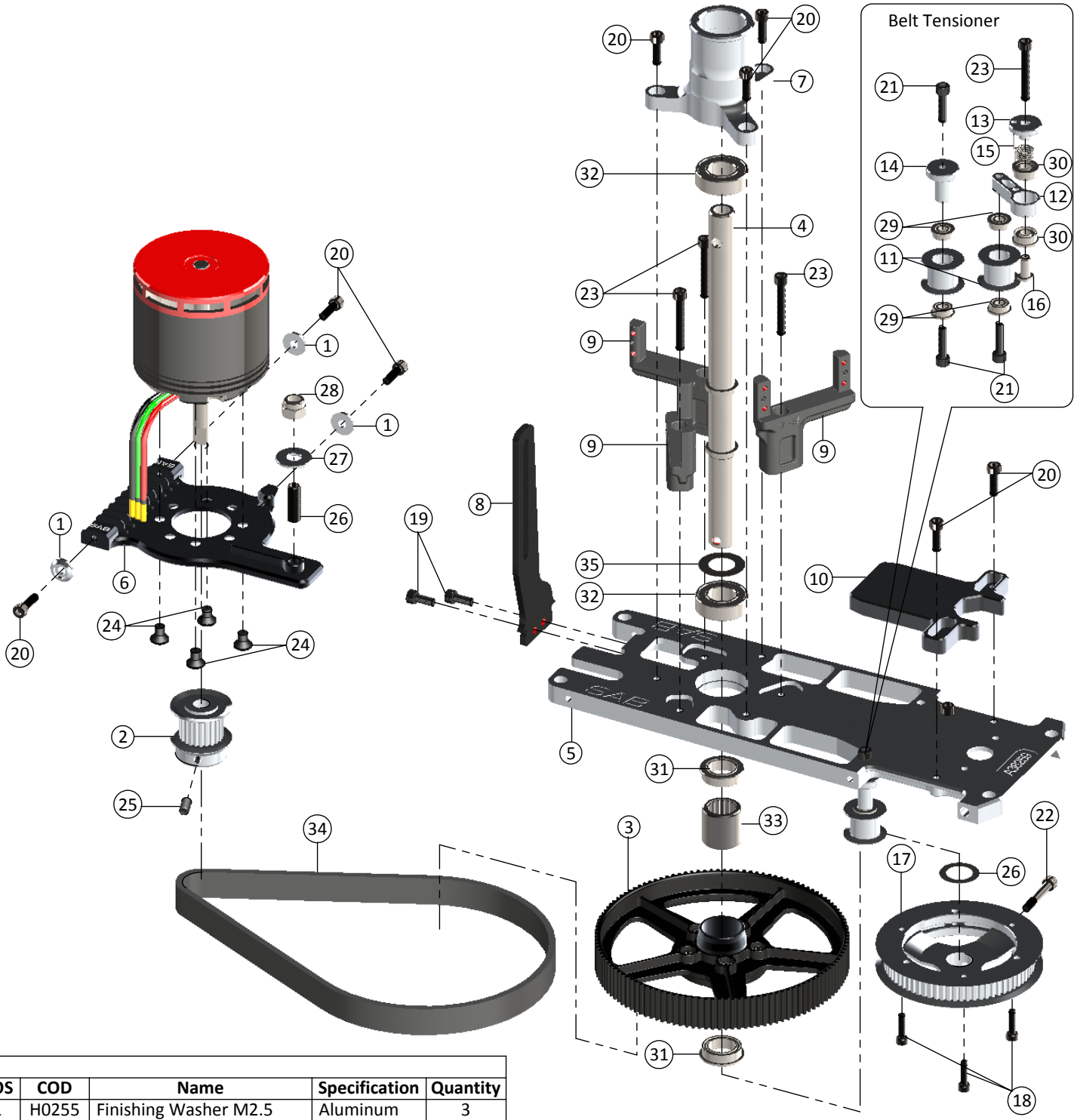

| POS | COD | Name | Specification | Quantity |
|-----|-------|-----------------------------|---------------|----------|
| 1 | H0255 | Finishing Washer M2.5 | Aluminum | 3 |
| 2 | H0501 | 20T Motor Pulley ASM | Aluminum | 1 |
| 3 | H0502 | 120T Main Pulley | Aluminum | 1 |
| 4 | H0507 | Main Shaft | Steel | 1 |
| 5 | H0519 | Main Plate | Aluminum | 1 |
| 6 | H0520 | Motor Support | Aluminum | 1 |
| 7 | H0522 | Main Shaft Support | Steel | 1 |
| 8 | H0533 | CF Anti-Rotation Guide | Carbon Fiber | 1 |
| 9 | H0548 | Plastic Servo Support | Plastic | 3 |
| 10 | H0564 | Flybarless Support | Aluminum | 1 |
| 11 | H0575 | Tail Belt Idler | Aluminum | 2 |
| 12 | H0576 | Tail Belt Tensioner Arm | Aluminum | 1 |
| 13 | H0577 | Column Belt Tensioner | Aluminum | 1 |
| 14 | H0578 | Column Belt Tensioner Axial | Aluminum | 1 |
| 15 | H0579 | Spring | Steel | 1 |
| 16 | H0580 | Block Tensioner | Aluminum | 1 |
| 17 | H0620 | Fonrt Tail Pulley ASM | Aluminum | 1 |
| 18 | HC008 | Socket Head Cap Screws | M2x8mm | 3 |
| 19 | HC018 | Socket Head Cap Screws | M2.5x6mm | 2 |

| POS | COD | Name | Specification | Quantity |
|-----|-------|----------------------------|-----------------|----------|
| 20 | HC020 | Socket Head Cap Screws | M2.5x8mm | 8 |
| 21 | HC022 | Socket Head Cap Screws | M2.5x10mm | 3 |
| 22 | HC031 | Head Cap Screws Shouldered | M2.5x15mm | 1 |
| 23 | HC032 | Socket Head Cap Screws | M2.5x18mm | 4 |
| 24 | HC132 | Flat Head Cap Screws | M3x5mm | 4 |
| 25 | HC144 | Cone Point Set Screws | M3x6mm | 1 |
| 26 | HC153 | Cone Point Set Screws | M4x12mm | 1 |
| 27 | HC184 | Washers | ø4.3 x ø11x1mm | 1 |
| 28 | HC212 | Metrix Nylon Nut | M4 | 1 |
| 29 | HC400 | Flanged Bearing | ø2.5 x ø6x2.5mm | 4 |
| 30 | HC402 | Flanged Bearing | ø3 x ø7x3mm | 2 |
| 31 | HC418 | Flanged Bearing | ø8 x ø12x3.5mm | 1 |
| 32 | HC419 | Bearing | ø8 x ø16x5mm | 2 |
| 33 | HC440 | One Way Bearing | ø8 x ø12x12mm | 2 |
| 34 | HC454 | Motor Belt | 304-2GT-09 | 1 |
| 35 | HC462 | Shim Washers | ø8 x ø12x0.2mm | 2 |

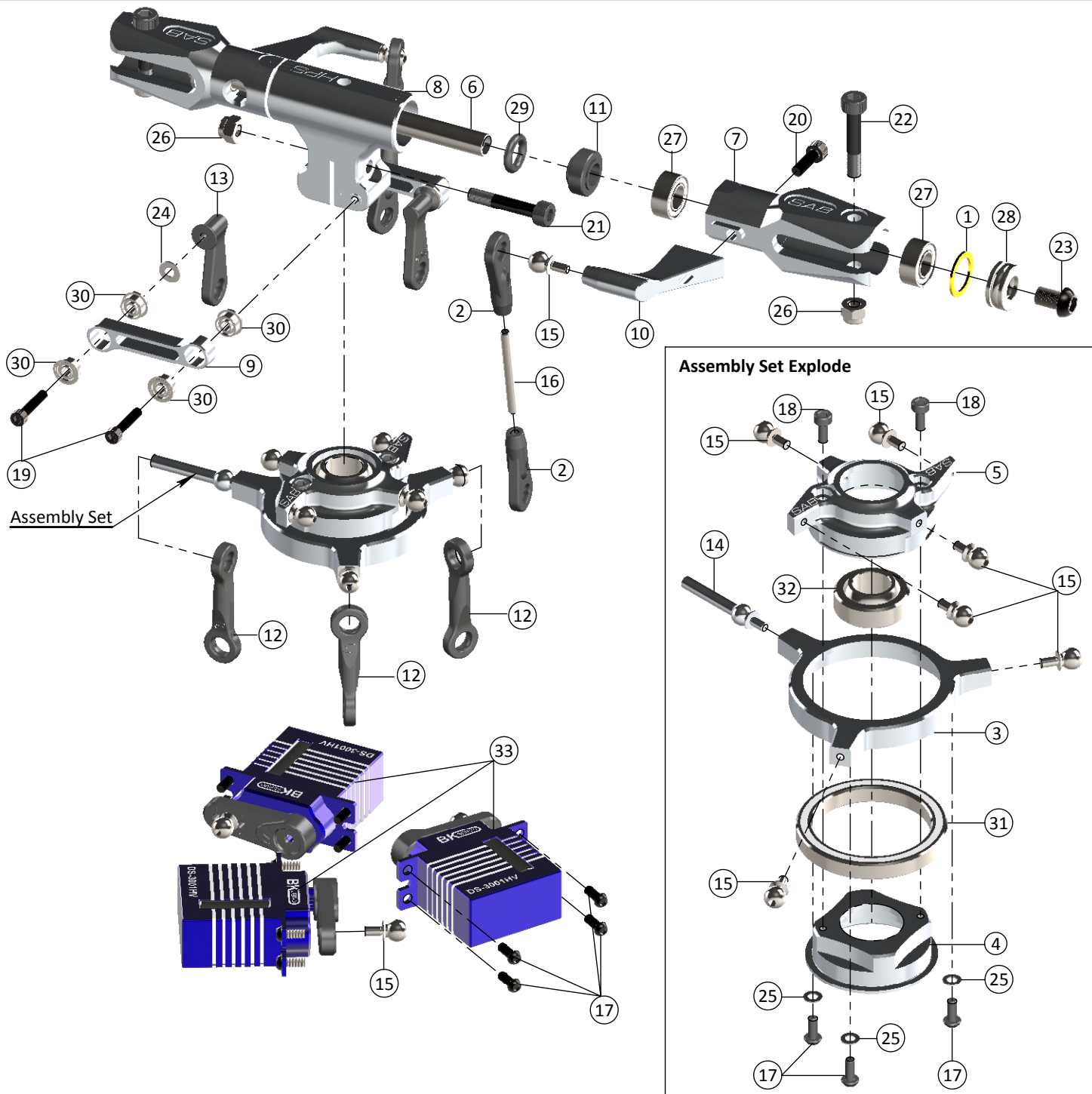





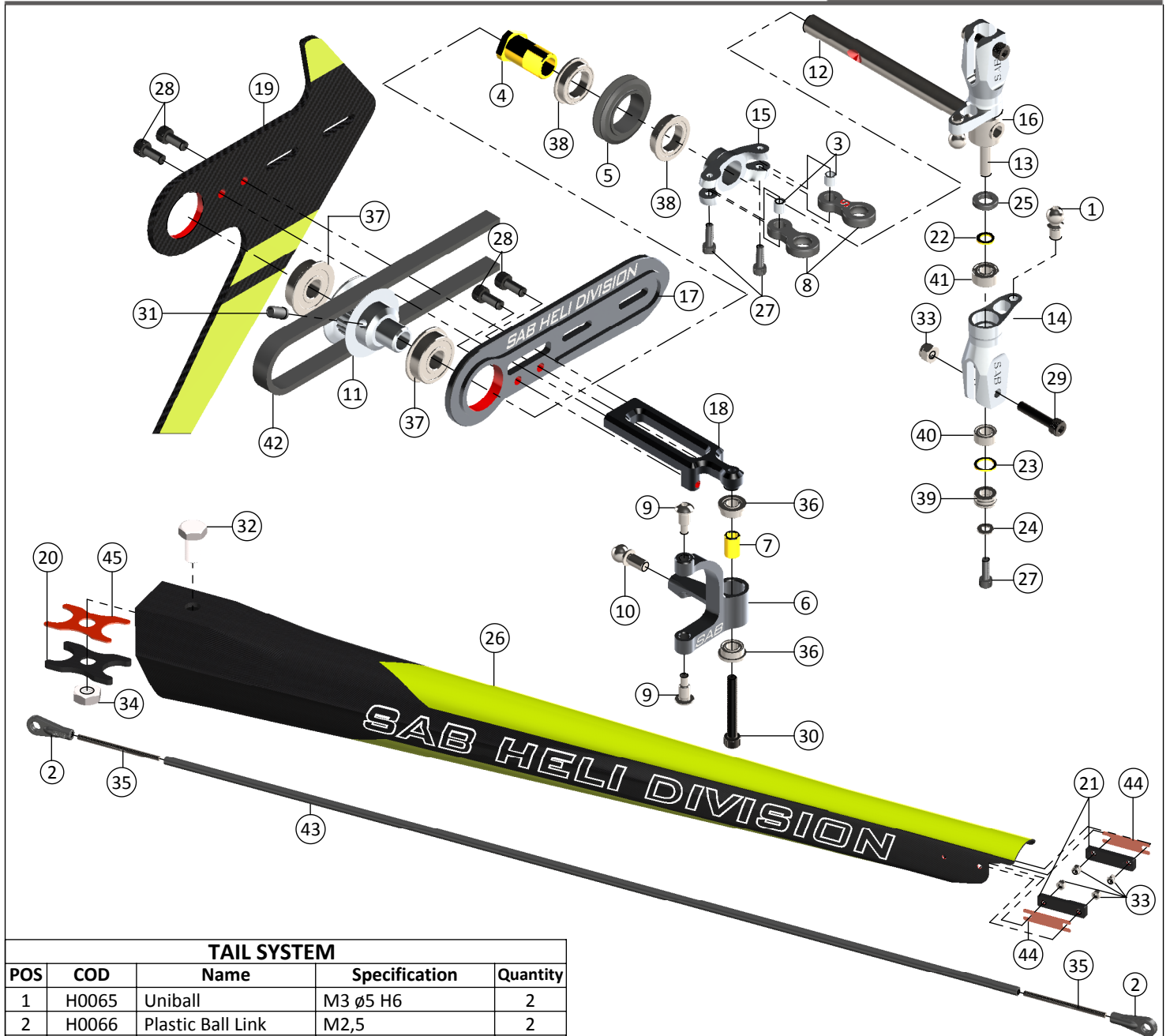













| HEAD SYSTEM | | | | |
|-------------|----------|-----------------------|-----------------|----------|
| POS | COD | Name | Specification | Quantity |
| 1 | H0349 | Washer | Ø 7,5x Ø 10x0,5 | 2 |
| 2 | H0403 | Plastic Linkage Ball | M2 | 4 |
| 3 | H0506-01 | Swashplate 01 | Aluminum | 1 |
| 4 | H0506-02 | Swashplate 02 | Aluminum | 1 |
| 5 | H0506-03 | Swashplate 03 | Aluminum | 1 |
| 6 | H0508 | Main Spindle | Steel | 1 |
| 7 | H0513 | Main Blade Grip | Aluminum | 2 |
| 8 | H0514 | Main HUB | Aluminum | 1 |
| 9 | H0516 | Swashplate Arm | Aluminum | 2 |
| 10 | H0517 | Main Blade Grip Arm | Aluminum | 2 |
| 11 | H0518 | Damper | Plastic | 2 |
| 12 | H0524 | Linkage Servos | Plastic | 3 |
| 13 | H0525 | Radius Plastic Arm | Plastic | 2 |
| 14 | H0537 | Uniball M2 Female | Aluminum | 1 |
| 15 | H0538 | Uniball M2 Male | Steel | 11 |
| 16 | H0561 | Linkage | M2x22mm | 2 |
| 17 | HC005 | Button Head Cap Screw | M2x5mm | 15 |













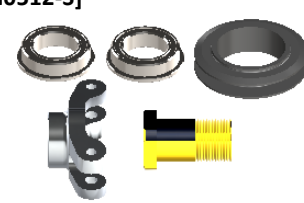

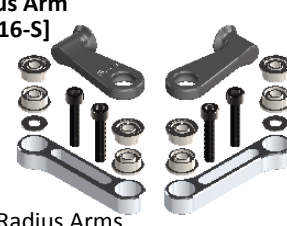
| HEAD SYSTEM | | | | |
|-------------|-------|--------------------------|------------------|----------|
| POS | COD | Name | Specification | Quantity |
| 18 | HC008 | Socket Head Cap Screws | M2 x 8mm | 2 |
| 19 | HC010 | Socket Head Cap Screws | M2 x 10mm | 4 |
| 20 | HC020 | Socket Head Cap Screws | M2.5 x 8mm | 2 |
| 21 | HC074 | Head Cap Screws Shoulder | M3 x 16mm | 1 |
| 22 | HC079 | Head Cap Screws Shoulder | M3 x 18mm | 2 |
| 23 | HC096 | Button Head Cap Screws | M4 x 6mm | 2 |
| 24 | HC170 | Washers | Ø 2.1x Ø 5 x 0.5 | 2 |
| 25 | HC172 | Washers | Ø 2.2x Ø 4x0.3 | 3 |
| 26 | HC206 | Metric Hex Nylon Nuts | M3 | 3 |
| 27 | HC411 | Bearing | Ø 5x Ø 10x4 | 4 |
| 28 | HC435 | Thrust Bearing | Ø 5x Ø 10x4 | 2 |
| 29 | HC453 | Oring | DI=6,75, S=1,78 | 2 |
| 30 | HC456 | Flanged Bearing | Ø 2x Ø 5x2.5 | 8 |
| 31 | HC459 | Rad Bearing | Ø 25x Ø 32x4 | 1 |
| 32 | HC460 | Spherical Bearing | Ø 12x Ø 22x7 | 1 |
| 33 | | DS-3001HV | BK Servo | 3 |

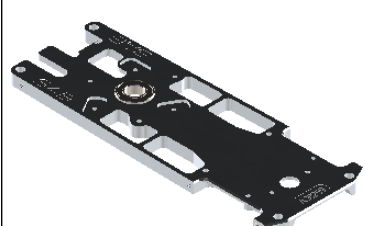

| TAIL SYSTEM | | | | |
|-------------|-------|------------------------|---------------|----------|
| POS | COD | Name | Specification | Quantity |
| 1 | H0065 | Uniball | M3 ø5 H6 | 2 |
| 2 | H0066 | Plastic Ball Link | M2,5 | 2 |
| 3 | H0076 | Grip Link Bushing | Brass | 2 |
| 4 | H0231 | Tail Pitch Slider 01 | Aluminum | 1 |
| 5 | H0232 | Tail Pitch Slider 02 | Aluminum | 1 |
| 6 | H0234 | Bell Crank Lever | Plastic | 1 |
| 7 | H0253 | Spacer Arm | ø2.5ø4x6.3 | 1 |
| 8 | H0261 | Tail Pitch Slider Link | Plastic | 2 |
| 9 | H0264 | Tail Pin | Steel | 2 |
| 10 | H0279 | Uniball | M3 ø5 H11.5 | 1 |
| 11 | H0504 | 20T Tail Pulley | Aluminum | 1 |
| 12 | H0509 | Tail Shaft | Steel | 1 |
| 13 | H0510 | Tail Spindle | Steel | 1 |
| 14 | H0511 | Tail Blade Grip | Aluminum | 2 |
| 15 | H0512 | Tail Slider | Aluminum | 1 |
| 16 | H0515 | Tail Hub | Steel | 1 |
| 17 | H0523 | Tail Side Plate | Aluminum | 1 |
| 18 | H0526 | Cros Tail Case | Aluminum | 1 |
| 19 | H0532 | Vertical Fin | Carbon Fiber | 1 |
| 20 | H0534 | CF Nut M8 Block | Carbon Fiber | 1 |
| 21 | H0535 | Locking Element Tail | Carbon Fiber | 2 |
| 22 | H0540 | Washer | ø3ø4.75x0.5 | 2 |
| 23 | H0541 | Washer | ø4.5ø5.9x0.5 | 2 |
| 24 | H0566 | Washer | ø2ø4.5x0.5 | 2 |
| 25 | H0567 | Tail Damper | Derlin | 2 |

| TAIL SYSTEM | | | | |
|-------------|-------|------------------------|---------------|----------|
| POS | COD | Name | Specification | Quantity |
| 26 | H0815 | Yellow Tail Boom | Carbon Fiber | 1 |
| 27 | HC004 | Socket Head Cap Screws | M2 x 6mm | 4 |
| 28 | HC018 | Socket Head Cap Screws | M2.5 x 6mm | 4 |
| 29 | HC026 | Socket Head Cap Screws | M2.5 x 12mm | 2 |
| 30 | HC032 | Socket Head Cap Screws | M2.5 x 18mm | 1 |
| 31 | HC144 | Cone Point Set Screws | M3 x 6mm | 1 |
| 32 | HC164 | Nylon Screws | M8 x 14mm | 1 |
| 33 | HC200 | Nylon Nut | M2.5 | 6 |
| 34 | HC224 | Nylon Nut | M8 | 1 |
| 35 | HC242 | Threaded Rod | M2.5x40mm | 2 |
| 36 | HC400 | Bearing | ø2.5ø6x2.5 | 2 |
| 37 | HC412 | Flanged Bearing | ø5ø13x4 | 2 |
| 38 | HC416 | Flanged Bearing | ø7ø11x2.5 | 2 |
| 39 | HC448 | Thrust Bearing | ø3ø6x2.5 | 2 |
| 40 | HC457 | Bearing | ø3ø6x2.5 | 2 |
| 41 | HC458 | Bearing | ø3ø7x3 | 2 |
| 42 | HC464 | Tail Belt | 1250mm | 1 |
| 43 | HC465 | Carbon Rod | ø4xø2.5x473mm | 1 |
| 44 | HA033 | Double Sided Tape | | 2 |
| 45 | HA034 | Double Sided Tape | | 1 |

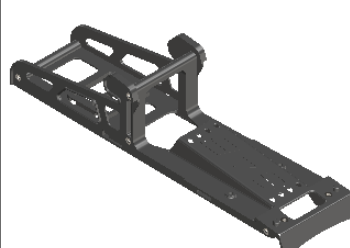
| | | | |
|--|---|--|--|
| <p>Uniball M2 \varnothing 5H6 [H0064-S]</p>  <ul style="list-style-type: none"> - 5 x Uniballs M2 \varnothing 5H6. - 5 x Uniball Spacers. - 5 x Socket Head Cap Screws M2x8mm. - 5 x Socket Head Cap Screws M2x6mm. | <p>Uniball M3x4 \varnothing 5H3 [H0065-S]</p>  <ul style="list-style-type: none"> - 5 x Uniballs M3x4 \varnothing 5H3.5. | <p>Plastic Ball Link [H0066-S]</p>  <ul style="list-style-type: none"> - 10 x Plastic Ball Link. | <p>Bell Crank Lever [H0234-S]</p>  <ul style="list-style-type: none"> - 1 x Bell Crank level. - 2 x Tail Pin. - 2 x Flanged Bearing \varnothing 2.5x \varnothing 6x2.5mm. - 1 x Spacer Arm \varnothing 2.5x \varnothing 4x6.3. - 1 x Head Cap Screws M2.5x18. - 1 x Uniball M3x \varnothing 4 H5. |
| <p>Finishing Washer M2.5 [H0255-S]</p>  <ul style="list-style-type: none"> - 10 x Finishing Washer M2.5. | <p>Tail Pitch Slider Link [H0261-S]</p>  <ul style="list-style-type: none"> - 2 x Tail Pitch Slider Link. - 2 x Spacer \varnothing 2x \varnothing 3x3mm. - 2 x Socket Head Cap M2x6mm. | <p>Plastic Ball Link M2 [H0403-S]</p>  <ul style="list-style-type: none"> - 5 x Plastic Ball Link M2. | <p>19T Motor Pulley [H0501-19-S]</p>  <ul style="list-style-type: none"> - 1 x 19T Motor Pulley Assembly. - 1 x Set Screws M3x6mm. |
| <p>20T Motor Pulley [H0501-20-S]</p>  <ul style="list-style-type: none"> - 1 x 20T Motor Pulley Assembly. - 1 x Set Screws M3x6mm. | <p>21T Motor Pulley [H0501-21-S]</p>  <ul style="list-style-type: none"> - 1 x 21T Motor Pulley Assembly. - 1 x Set Screws M3x6mm. | <p>22T Motor Pulley [H0501-22-S]</p>  <ul style="list-style-type: none"> - 1 x 22T Motor Pulley Assembly. - 1 x Set Screws M3x6mm. | <p>23T Motor Pulley [H0501-23-S]</p>  <ul style="list-style-type: none"> - 1 x 23T Motor Pulley Assembly. - 1 x Set Screws M3x6mm. |
| <p>24T Motor Pulley [H0501-24-S]</p>  <ul style="list-style-type: none"> - 1 x 24T Motor Pulley Assembly. - 1 x Set Screws M3x6mm. | <p>25T Motor Pulley [H0501-25-S]</p>  <ul style="list-style-type: none"> - 1 x 25T Motor Pulley Assembly. - 1 x Set Screws M3x6mm. | <p>120T Main Pulley [H0502-S]</p>  <ul style="list-style-type: none"> - 1 x 120T Main Pulley . - 1 x Main Pulley Support. - 2 x Shims \varnothing 8x\varnothing 14x0,2mm. - 5 x Head Cap Screws M2x5mm. - 2 x Flanged Bearing \varnothing 8x\varnothing 12x3,5mm. - 1 x One Way Bearing \varnothing 8x\varnothing 12x12mm. | |
| <p>20T Tail Pulley [H0504-S]</p>  <ul style="list-style-type: none"> - 1 x 20T Tail Pulley Assembly. - 1 x Set Screws M3x6mm. | <p>Washplate Set [H0506-S]</p>  <ul style="list-style-type: none"> - 1 x Swashplate Assembly. - 1 x Rad Bearings \varnothing 25x \varnothing 32x4. - 6 x Uniballs M2 Male. - 1 x Uniballs M2 Female. - 3 x Button Cap Screws M2x5. - 3 x Swasher \varnothing 2.2x \varnothing 4x0.3. - 2 x Head Cap Screws M2x8mm. | | <p>Spindle Shaft [H0508-S]</p>  <ul style="list-style-type: none"> - 1 x Spindle Shaft. - 2 x Button Cap Screw M4x6mm. |
| <p>Main Shaft [H0507-S]</p>  <ul style="list-style-type: none"> - 1 x Main Shaft. - 1 x Head Cap Screw M3x16mm. - 1 x Metrix Nylon Nut M3. | | | |

| | | | |
|--|--|---|---|
| <p>Tail Shaft [H0509-S]</p>  <ul style="list-style-type: none"> - 1 x Tail Shaft. - 1 x Tail Hub. - 1 x Set Screw M3x6mm. - 2 x Tail Damper. | <p>Tail Spindle [H0510-S]</p>  <ul style="list-style-type: none"> - 1 x Tail Spindle. - 1 x Socket Cap Screw M2x6mm. - 2 x Washer $\varnothing 2x \varnothing 4.5x0.5mm$. | <p>Tail Blade Grip [H0511-S]</p>  <ul style="list-style-type: none"> - 2 x Tail Blade Grip. - 2 x Thrust Bearing $\varnothing 3x \varnothing 6x2.5mm$. - 2 x Bearing $\varnothing 3x \varnothing 7x3mm$. - 2 x Bearing $\varnothing 3x \varnothing 6x2.5mm$. - 2 x Washer $\varnothing 3x \varnothing 4.75x0.5mm$. - 2 x Washer $\varnothing 4.5x \varnothing 5.9x0.5mm$. - 2 x Washer $\varnothing 2x \varnothing 4.5x0.5mm$. - 2 x Uniball M3. | |
| <p>Tail Pitch Slider [H0512-S]</p>  <ul style="list-style-type: none"> - 1 x Tail Pitch Slider 01. - 1 x Tail Pitch Slider 02. - 1 x Tail Pitch Slider 03. - 2 x Flanged Bearings $\varnothing 8x \varnothing 12x3.5mm$. | <p>Main Blade Grip [H0513-S]</p>  <ul style="list-style-type: none"> - 2 x Blade Grip. - 2 x Thrust Bearing $\varnothing 5x \varnothing 10x4$. - 4 x Bearing $\varnothing 5x \varnothing 10x4$. - 2 x Washer $\varnothing 7.5x \varnothing 10x0.5$. - 2 x Button Head Socket Cap M4x6. - 2 x Washer $\varnothing 5x \varnothing 7x0.1$. | <p>Center Hub [H0514-S]</p>  <ul style="list-style-type: none"> - 1 x Center Hub. - 1 x Socket Head Shoulder M3x16. - 1 x Metrix Hex Nylon Nut M3. | |
| <p>Radius Arm [H0516-S]</p>  <ul style="list-style-type: none"> - 2 x Radius Arms. - 2 x Uniball Radius Arms. - 4 x Head Cap Screws M2x10mm. - 8 x Flanged Bearings $\varnothing 2x \varnothing 5x2.5$. - 2 x Washer $\varnothing 2.1x \varnothing 5x0.5mm$. | <p>Blade Grip Arm [H0517-S]</p>  <ul style="list-style-type: none"> - 2 x Blade Grip Arm. - 2 x Head Cap Screws M2.5x8. - 2 x Uniball M2. | <p>Damper Derlin [H0518-S]</p>  <ul style="list-style-type: none"> - 2 x Damper Derlin. - 2 x Oring DI = 6.75, S = 1.78. - 2 x Washer $\varnothing 7.5x \varnothing 10x0.5$. - 2 x Button Head Cap M4x6. - 2 x Washer $\varnothing 5x \varnothing 7x0.1$. | <p>Main Plate [H0519-S]</p>  <ul style="list-style-type: none"> - 1 x Main Plate. - 1 x Bearing $\varnothing 8x \varnothing 16x5$. |
| <p>Motor Support [H0520-S]</p>  <ul style="list-style-type: none"> - 1 x Motor Support. - 3 x Head Cap Screws M2.5x8. - 3 x Finishing Washer M2.5. - 1 x Set Screws M4x12. - 1 x Metrix Hex Nylon Nut M4. - 1 x Washer $\varnothing 4x \varnothing 11x1mm$. | <p>Main Shaft Support [H0522-S]</p>  <ul style="list-style-type: none"> - 1 x Main Shaft Support. - 3 x Head Cap Screws M2.5x8. - 1 x Bearing $\varnothing 8x \varnothing 16x5$. | <p>Aluminum Tail Plate [H0523-S]</p>  <ul style="list-style-type: none"> - 1 x Aluminum Tail Plate. - 1 x Flanged Bearing $\varnothing 5x \varnothing 13x4$. - 2 x Head Cap Screws M2.5x10. - 2 x Finishing Washer M3. | <p>Linkage Servo [H0524-S]</p>  <ul style="list-style-type: none"> - 3 x Aluminum Tail Plate. |
| <p>Plastic Radius Arm [H0525-S]</p>  <ul style="list-style-type: none"> - 2 x Plastic Radius Arm. - 2 x Washer $\varnothing 2.2x \varnothing 5x0.3mm$. | <p>Cros Tail Case [H0526-S]</p>  <ul style="list-style-type: none"> - 1 x Cros Tail Case. - 2 x Head Cap Screw M2.5x6. | <p>Plastic Battery Support [H0529-S]</p>  <ul style="list-style-type: none"> - 1 x Plastic Battery Support. | <p>Tail Servo Support [H0530-S]</p>  <ul style="list-style-type: none"> - 1 x Tail Servo Support. |



Main Frame (H0531-S)

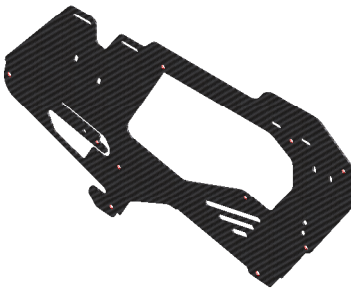

- 1 x Main Frame.

Vertical Fin (H0532-S)

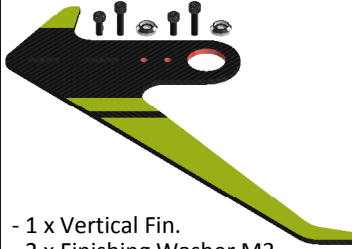

- 1 x Vertical Fin.
- 2 x Finishing Washer M3.
- 2 x Head Cap Screws M2.5x6.
- 2 x Head Cap Screws M2.5x10.

Anti-Rotation Guide (H0533-S)



- 1 x Anti-Rotation Guide.
- 2 x Head Cap Screws M2.5x6.

Boom Accessories (H0535-S)



- 1 x M8 Carbon Block.
- 2 x Locking Element Tail.
- 1 x Double Sided Tape [HA034].
- 1 x Double Sided Tape [HA033].
- 1 x Metrix Hex Nylon Nut M8.
- 1 x Metrix Hex Nylon Screw M8.
- 4 x Metrix Hex Nylon Nut M2.5.

Battery Tray (H0536-S)



- 1 x Battery Tray.
- 1 x Battery Straps.
- 1 x Double Sided Tape .

Uniball M2 Female (H0537-S)



- 2 x Uniball M2 Female.

Uniball M2 Male (H0538-S)



- 5 x Uniball M2 Male.

Battery Block (H0539-S)



- 1 x Battery Block.
- 1 x Button Cap Screws M2x5mm.

Tail Spacer KIT (H0540-S)



- 2 x Washer $\phi 3x \phi 4.75x0.5$.
- 2 x Washer $\phi 4.5x \phi 5.9x0.5$.
- 2 x Washer $\phi 2x \phi 4.5x0.5$.
- 2 x Oring ID=2.9, S=1.78.
- 2 x Head Cap Screw M2x6mm.

Canopy Nut (H0542-S)



- 2 x Canopy Nut.
- 2 x Set Screw M4x20mm.

Canopy Lock (H0543-S)



- 2 x Canopy Lock.

Plastic Servo Support (H0548-S)



- 1 x Plastic Servo Support.
- 1 x Socket Head Cap Screws M2.5x18mm.

Linkage Rod M2 (H0561-S)



- 2 x Linkage Rod M2x22.
- 4 x Plastic Ball Link M2.

FBL Support (H0564-S)

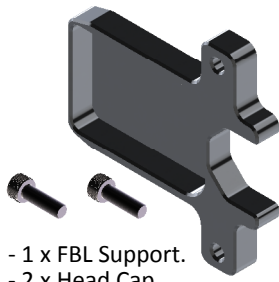

- 1 x FBL Support.
- 2 x Head Cap Screw M2.5x8mm.

Tail Fin and Landing Gear Stickers (H0565-S)



- 2 x Tail Fin Stickers.
- 2 x Landing Gear Stickers.

Aluminum Tail Belt Guide (H0568-S)



- 1 x Aluminum Tail Belt Guide Set.

Tail Servo Spacer (H0572-S)



- 4 x Tail Servo Spacer.

Front Tail Pulley [H0620-S]



- 1 x Front Tail Pulley Assembly.
- 1 x Head Cap Screws Shoulder M2.5x15.
- 3 x Head Cap Screws M2x8mm.

Yellow Tail Boom (H0815-S)



- 1 x Yellow Tail Boom.
- 1 x M8 Carbon Block.
- 2 x Locking Element Tail.
- 1 x Double Sided Tape [HA034].

Yellow Canopy (H0816-S)















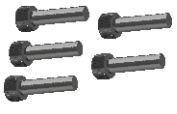











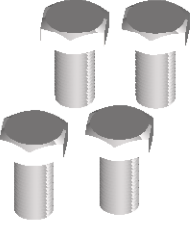
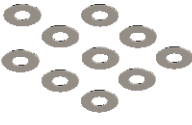

- 1 x Double Sided Tape [HA033].
- 1 x Metrix Hex Nylon Nut M8.
- 1 x Metrix Hex Nylon Screw M8.
- 4 x Metrix Hex Nylon Nut M2.5.

Yellow Canopy (H0816-S)

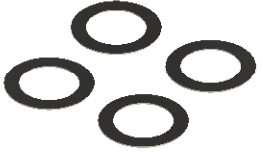
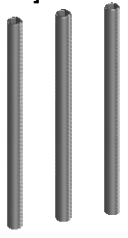

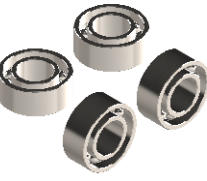
- 1 x Yellow Canopy.
- 1 x Canopy Edge Protection.
- 2 x Canopy Grommet.

| | | | | |
|--|--|--|---|--|
| <p>[HC002-S]</p>  <p>- 5 x Socket Head Cap M2x5mm.</p> | <p>[HC004-S]</p>  <p>- 5 x Socket Head Cap M2x6mm.</p> | <p>[HC005-S]</p>  <p>- 5 x Button Head Cap M2x5mm.</p> | <p>[HC008-S]</p>  <p>- 5 x Socket Head Cap M2x8mm.</p> | <p>[HC010-S]</p>  <p>- 5 x Socket Head Cap M2x10mm.</p> |
| <p>[HC018-S]</p>  <p>- 5 x Socket Head Cap M2.5x6mm.</p> | <p>[HC019-S]</p>  <p>- 5 x Button Head Cap Special M2.5x6mm.</p> | <p>[HC020-S]</p>  <p>- 5 x Socket Head Cap M2.5x8mm.</p> | <p>[HC022-S]</p>  <p>- 5 x Socket Head Cap M2.5x10mm.</p> | <p>[HC026-S]</p>  <p>- 5 x Socket Head Cap M2.5x12mm.</p> |
| <p>[HC031-S]</p>  <p>- 5 x Socket Head Cap Shoulder M2.5x15mm.</p> | <p>[HC032-S]</p>  <p>- 5 x Socket Head Cap M2.5x18mm.</p> | <p>[HC074-S]</p>  <p>- 2 x Socket Head Cap Shoulder M3x16mm. - 2 x Metrix Nylon Nut M3.</p> | <p>[HC096-S]</p>  <p>- 5 x Button Head Cap Screws M4x6mm.</p> | <p>[HC144-S]</p>  <p>- 5 x Cone Point Set Screw M3x6mm.</p> |
| <p>[HC155-S]</p>  <p>- 5 x Cone Point Set Screw M4x20mm.</p> | <p>[HC156-S]</p>  <p>- 5 x Cone Point Set Screw M4x12mm.</p> | <p>[HC164-S]</p>  <p>- 4 x Nylon Hex Nut M8x14mm.</p> | <p>[HC170-S]</p>  <p>- 10 x Washer Ø2,2xØ5x0,3mm.</p> | <p>[HC184-S]</p>  <p>- 5 x Washer Ø4,3xØ11x1mm.</p> |
| <p>[HC200-S]</p>  <p>- 10 x Metrix Nylon Nut M2.5.</p> | <p>[HC206-S]</p>  <p>- 10 x Metrix Nylon Nut M3.</p> | <p>[HC212-S]</p>  <p>- 10 x Metrix Nylon Nut M4.</p> | <p>[HC224-S]</p>  <p>- 4 x Metrix Nylon Nut M8.</p> | <p>[HC228-S]</p>  <p>- 4 x Shim Ø8xØ14x0,2mm.</p> |
| <p>[HC242-S]</p>  <p>- 3 x Thread Rod M2,5x40mm.</p> | <p>[HC400-S]</p>  <p>- 4 x Flanged Bearing Ø2.5xØ6x2.6mm.</p> | <p>[HC411-S]</p>  <p>- 4 x Bearing Ø5xØ10x4mm.</p> | <p>[HC412-S]</p>  <p>- 4 x Flanged Bearing Ø5xØ13x4mm.</p> | <p>[HC416-S]</p>  <p>- 2 x Flanged Bearing Ø7xØ11x2.5mm.</p> |

| | | | | |
|--|---|--|---|---|
| <p>[HC418-S]</p>  <p>- 2 x Flanged Bearing Ø8xØ12x3.5mm.</p> | <p>[HC419-S]</p>  <p>- 2 x Bearing Ø8xØ16x5mm.</p> | <p>[HC435-S]</p>  <p>- 2 x Thrust Bearing Ø5xØ10x4mm.</p> | <p>[HC440-S]</p>  <p>- 1 x One Way Bearing Ø8xØ12x12mm.</p> | <p>[HC448-S]</p>  <p>- 2 x Thrust Bearing Ø3xØ6x2.5mm.</p> |
| <p>[HC450-S]</p>  <p>- 5 x Washer Ø5xØ7x0.1mm.</p> | <p>[HC453-S]</p>  <p>- 2 x Oring DI=6,75, S=1,78. - 2 x Oring DI=2.9, S=1,78.</p> | <p>[HC454-S]</p>  <p>- 1 x Belt 304-2GT-09.</p> | <p>[HC456-S]</p>  <p>- 4 x Flanged Bearing Ø2xØ5x2.5mm.</p> | <p>[HC457-S]</p>  <p>- 4 x Bearing Ø3Ø6x2.5mm.</p> |
| <p>[HC458-S]</p>  <p>- 4 x Bearing Ø3Ø7x3mm.</p> | <p>[HC459-S]</p>  <p>- 1 x Rad Bearing Ø25Ø32x4mm.</p> | <p>[HC460-S]</p>  <p>- 1 x Spherical Bearing Ø12xØ22x7mm.</p> | <p>[HC462-S]</p>  <p>- 4 x Shim Ø8xØ12x0.1mm.</p> | <p>[HC464-S]</p>  <p>- 1 x Belt 1250-HTD-2.</p> |
| <p>[HC465-S]</p>  <p>- 1 x Tail Push Rod Ø4xØ2,5x473mm. - 2 x Plastic Ball Link. - 2 x Thread Rod M2,5.</p> | <p>[HA016-S]</p>  <p>- 2 x Wrench Tool M8,M6.</p> | <p>[HA021-S]</p>  <p>- 4 x Canopy Grommet.</p> | <p>[HA032-S]</p>  <p>- 1 x Foam Blade Holder.</p> | <p>[HA035-S]</p>  <p>- 2 x Double-sided Tape 1 mm Battery .</p> |
| <p>[HA036-S]</p>  <p>- 2 x Battery Straps.</p> | <p>[HA052-S]</p>  <p>- 1 x Tail Servo Horn. - 3 x Cyclic Servo Horn.</p> | <p>[HA112-S]</p>  <p>- 1 x Canopy Edge Protection (1m).</p> | <p>[BW0370-S]</p>  <p>- 2 x Tail Blade 70mm.</p> | <p>[420TB-3DS]</p>  <p>- 2 x Main Blade 420mm.</p> |

"Running 420 mm ThunderBolt blades, the new Goblin 420 has an awesome feeling due to the super light airframe.

KSE landing gear, belt tension upgrade and the amazing Black thunder look.

A small machine that feels like a bigger one, fast and smooth...I like it!!"



Kyle Stacy
Kyle Stacy



WWW.GOBLIN-HELICOPTER.COM

SAB HELI DIVISION