



Goblin 700 COMPETITION Manual

Goblin 700 Competition Manual

Release 1.0 - October 2013

SAB HELI DIVISION S.R.L.

Via San Crispino, 47

47030 San Mauro Pascoli (FC) - ITALY



The Goblin Competition is the result of all the feedback and experienced gained with the original Goblin. All the changes incorporated into the Goblin Competition create a model even more reliable and efficient than ever before. New colors, new composite materials and many upgrades are included in this kit making it the best Goblin ever.

Please read this user manual carefully, it contains instructions for the correct assembly of the model. Please refer to the web site www.goblin-helicopter.com for updates and other important information.

VERY IMPORTANT

Inside Box 5, you will find Bag 21. This bag contains your serial number tag. Please take a moment to register your kit online via our web site at:

<http://www.goblin-helicopter.com>

It is extremely important that you take a moment to register your helicopter with us. This is the only way to ensure that you are properly informed about changes to your kit, such as upgrades, retrofits and other important developments. SAB Heli Division cannot be held responsible for issues arising with your model and will not provide support unless you register your serial number.

To mount the serial number tag on your helicopter, please refer to page 32.

Thank you for your purchase, we hope you enjoy your new Goblin helicopter!

SAB Heli Division

INDEX

1 – Serial Number
2 – Important Notes ⚠
 3 – Components and Box
 4 – Carbon frame Assembly
 5 – Transmission Assembly
 6 – Main rotor

7 – Assembling The Modules
 8 – Installation of Swashplate Servos
 9 – Installation of The ESC
 10 – Installation of Flybarless Unit and RX
 11 – Installation of The Motor
 12 – Tail Assembly

13 – Installation of the Boom, Canopy
 14 – Battery
15 – In flight ⚠
 16 – Maintenance
 17 – Exploded Views
 18 – Spare Parts

SPECIFICATIONS

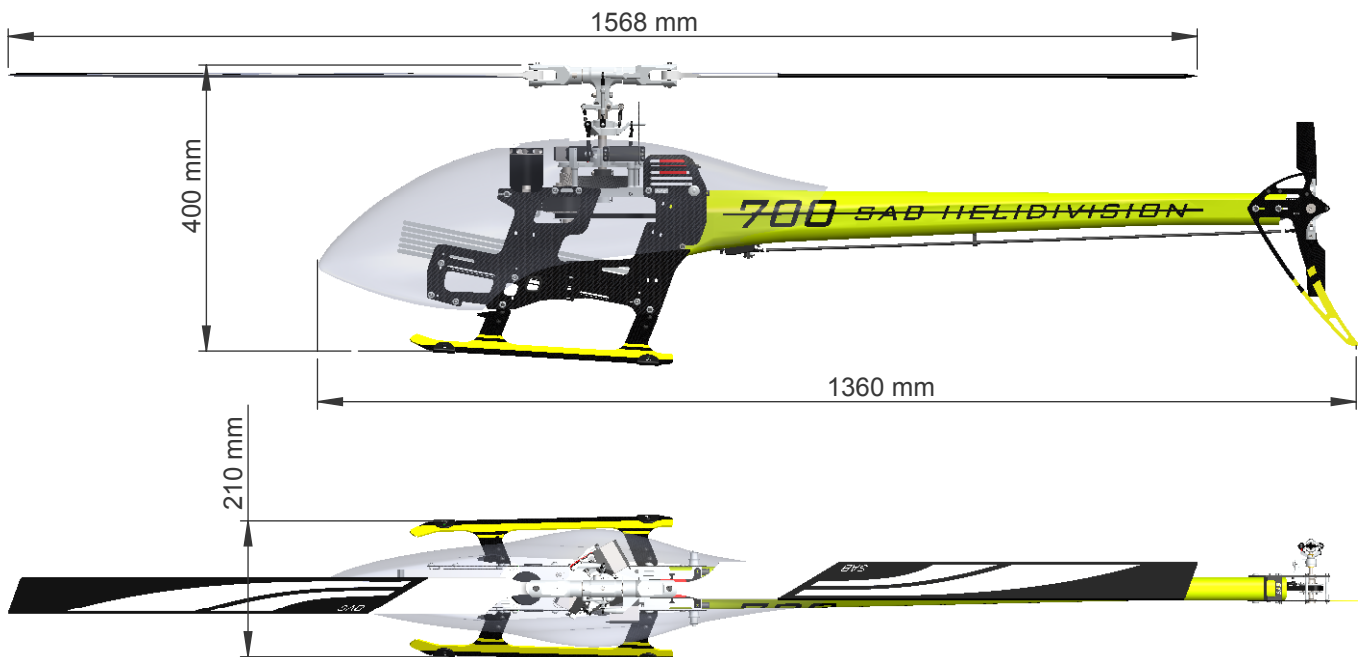

Main rotor diameter: 1568mm (with 690mm blades)
 Main blade length: 690 to 710mm
 Tail rotor diameter: 305mm
 Tail blade length: 115mm
 Main shaft diameter: 12mm
 Tail shaft diameter: 6mm
 Spindle diameter: 10mm

Weight including standard electronics: 3620g (excluding batteries).
 Motor size: Maximum 64mm diameter, maximum height 64mm
 Battery compartment: 60x58x350mm (adaptable to 75x58x350mm)

SAB HELI DIVISION



IMPORTANT NOTES

- *This radio controlled helicopter is not a toy.
- *This radio controlled helicopter can be very dangerous.
- *This radio controlled helicopter is a technically complex device which has to be built and handled very carefully.
- *This radio controlled helicopter must be built following these instructions. This manual provides the necessary information to correctly assemble the model. It is necessary to carefully follow all the instructions.
- *Inexperienced pilots must be monitored by expert pilots.
- *All operators must wear safety glasses and take appropriate safety precautions.
- *A radio controlled helicopter must only be used in open spaces without obstacles, and far enough from people to minimize the possibility of accidents or of injury to property or persons.
- *A radio controlled helicopter can behave in an unexpected manner, causing loss of control of the model, making it very dangerous.
- *Lack of care with assembly or maintenance can result in an unreliable and dangerous model.

Neither SAB Heli Division nor its agents have any control over the assembly, maintenance and use of this product. Therefore, no responsibility can be traced back to the manufacturer. You hereby agree to release SAB Heli Division from any responsibility or liability arising from the use of this product.

SAFETY GUIDELINES

- *Fly only in areas dedicated to the use of model helicopters.
- *Follow all control procedures for the radio frequency system.
- *It is necessary that you know your radio system well. Check all functions of the transmitter before every flight.
- *The blades of the model rotate at a very high speed; be aware of the danger they pose and the damage they may cause.
- *Never fly in the vicinity of other people.

NOTES FOR ASSEMBLY

Please refer to this manual for assembly instructions for this model.

Follow the order of assembly indicated. The instructions are divided into chapters, which are structured in a way that each step is based on the work done in the previous step. Changing the order of assembly may result in additional or unnecessary steps.

Use thread lockers and retaining compounds as indicated. In general, each bolt or screw that engages with a metal part requires thread lock.

It is necessary to pay attention to the symbols listed below:

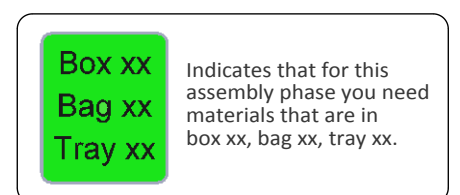
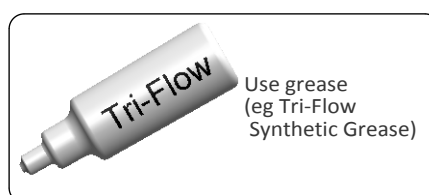
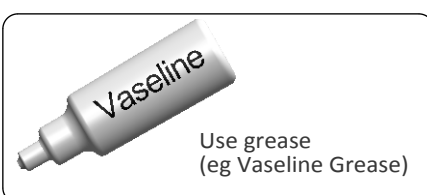
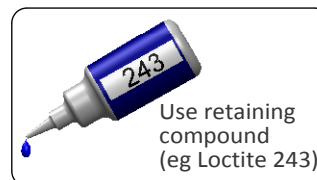
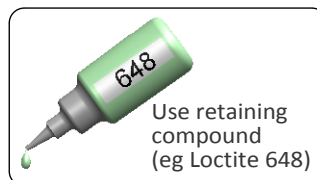



ADDITIONAL COMPONENTS REQUIRED

- *Electric Motor: 12S – 480/520Kv
Maximum diameter 64mm,
Maximum height 64mm,
Pinion shaft diameter 6/8mm
- *Speed controller: minimum 120A to be safe
- *Batteries: 12S - 5000mAh
- *1 flybarless 3 axis control unit
- *Radio power system, if not integrated with the ESC
- *3 cyclic servos
- *1 tail rotor servo
- *6 channel radio control system on 2.4 GHz

(See configuration examples on page 21)

TOOLS, LUBRICANTS, ADHESIVES

- *Generic pliers
- *Hexagonal driver, size 1.5,2,2.5,3,4mm
- *4mm T-Wrench
- *5.5mm Socket wrench (for M3 nuts)
- *8mm Hex fork wrench (for M5 nuts)
- *Medium threadlocker (eg. Loctite 243)
- *Strong retaining compound (eg. Loctite 648)
- *Spray lubricant (eg. Try-Flow Oil)
- *Synthetic grease (eg. Tri-Flow Synthetic Grease)
- *Grease (eg. Vaseline grease)
- *Cyanoacrylate adhesive
- *Pitch Gauge (for set-up)
- *Soldering equipment (for motor wiring)

Inside the main box there are:

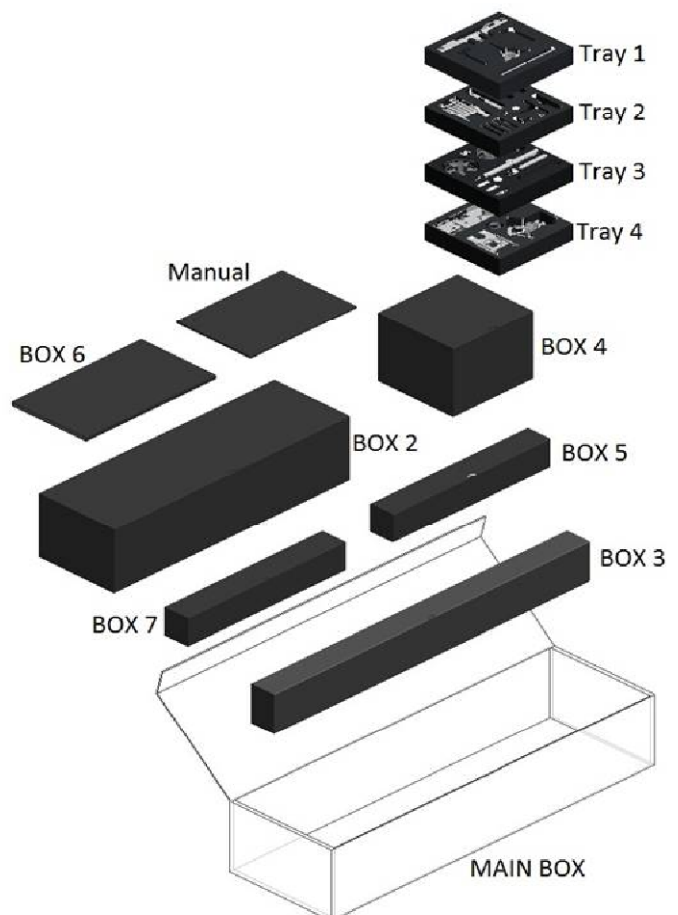

Inside the main box:

- Box 2: Canopy, Blade Holder.
- Box 3: Boom, Blades, Tail blades, Carbon rod.
- Box 4: Mechanical parts in 4 trays:
Tray 1: Main rotor
Tray 2: Carbon frame and tail rotor
Tray 3: Transmission
Tray 4: Main structure
- Box 5: Bags
- Box 6: Carbon parts
- Box 7: Carbon parts

The assembly process is described in the following chapters. Each chapter provides you with the box, bag and/or foam tray numbers you will need for that chapter. The information is printed in a green box in the upper right hand corner of the page at the beginning of every chapter.



4-Carbon Frame

 The manufacturing process of the carbon parts often leaves micro-burrs and sharp edges. We recommend de-burring the edges to minimize the risks of electrical wire cuts, etc. Very important in red line zone.

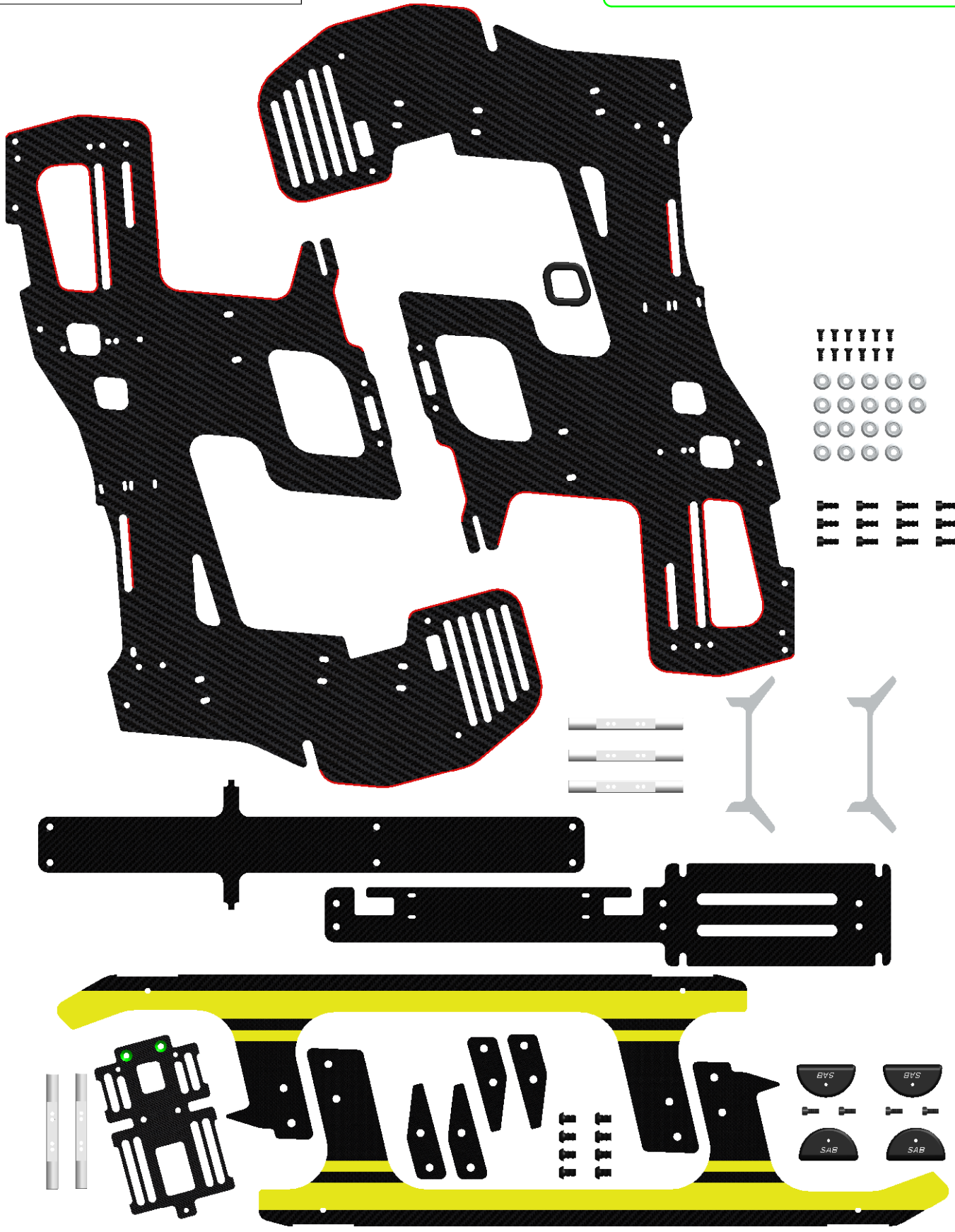



Box 7, Bag 1-1, Tray 2

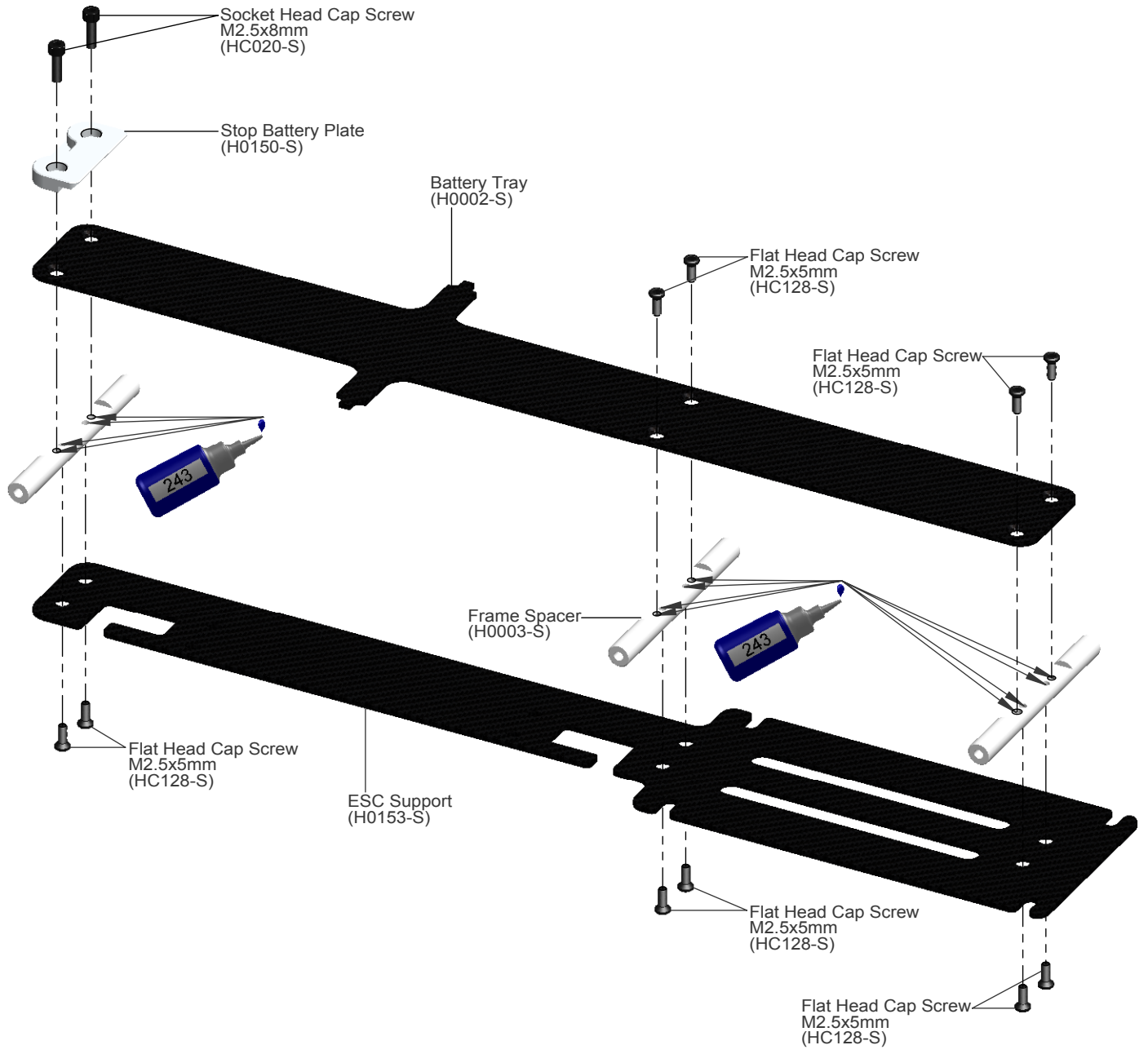

- Socket Head Cap Screw M2.5x8mmx2
- Flat Head Cap Screw M2.5x5mmx10





Box 6, Bag 1-2;1-3, Tray 2

ESC Support Assembly

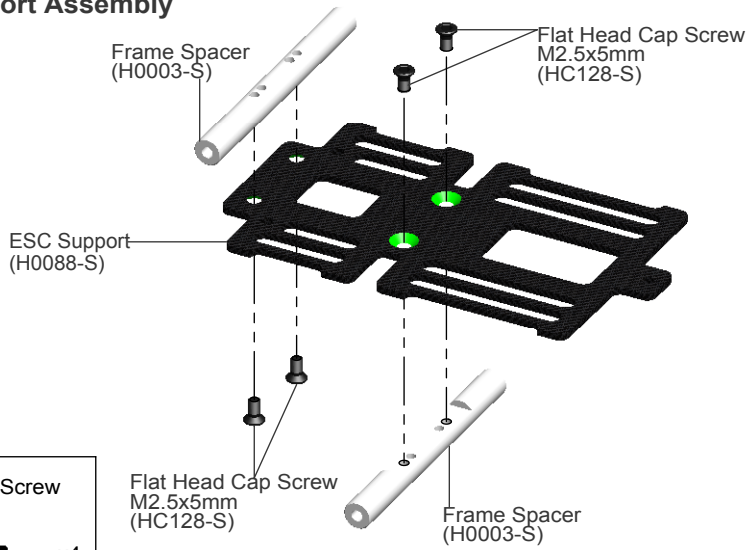

Note:

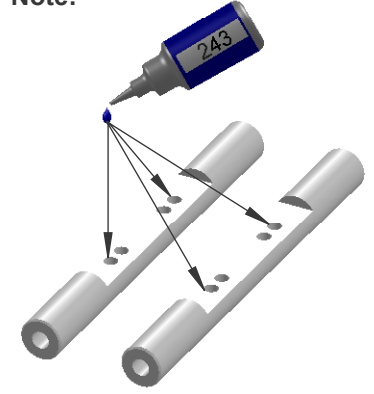

Flat Head Cap Screw
M2.5x5mm
.....x4

Note:

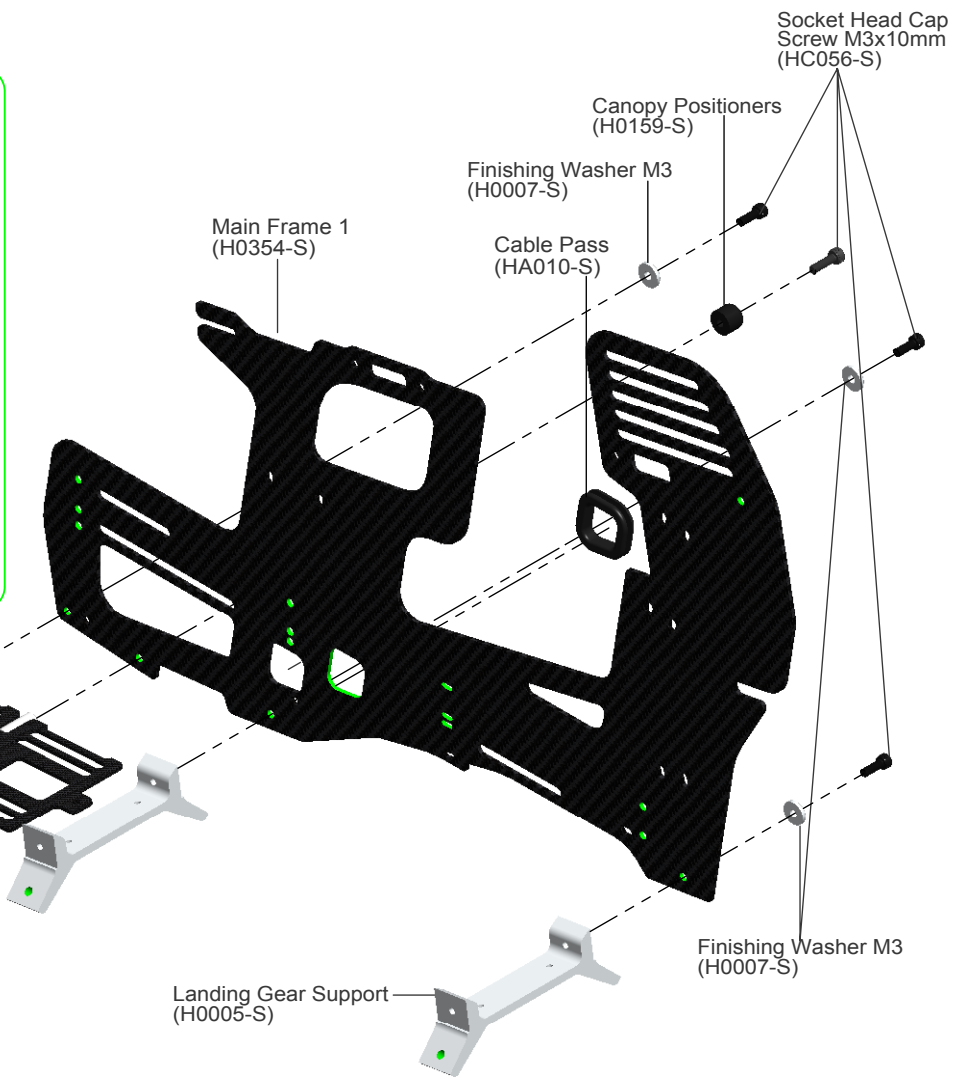
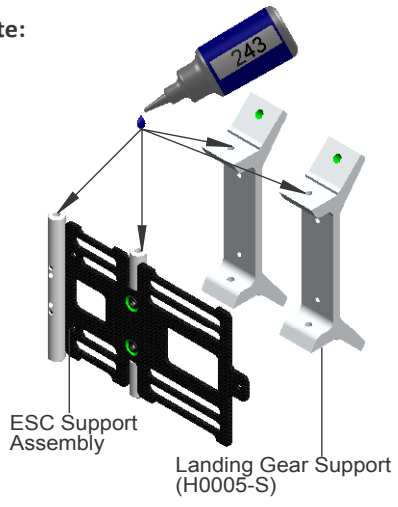

Socket Head Cap Screw
M3x10mm
.....x4

Finishing Washer M3
.....x3





Box 6, Bag 1-2

Note:
 Choose the position for the batteries
 For the best 3D performance (with 12S-5000 batteries)
 we recommend position 1

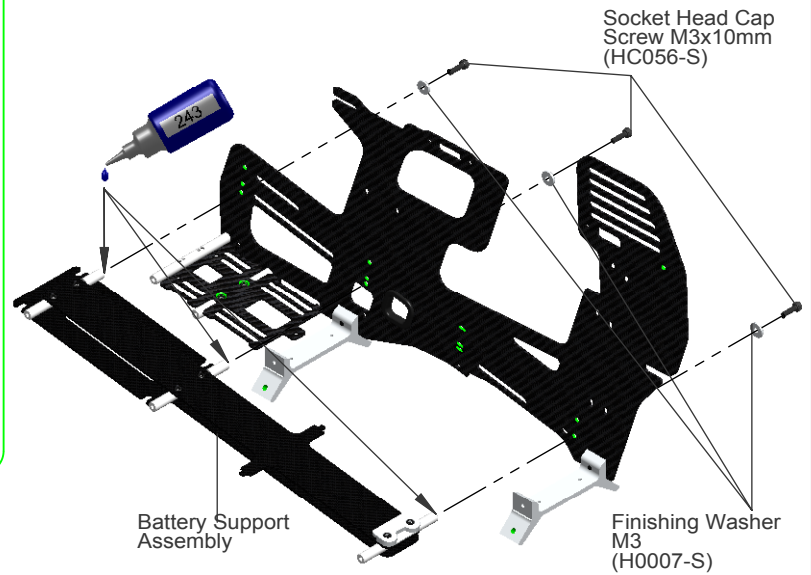
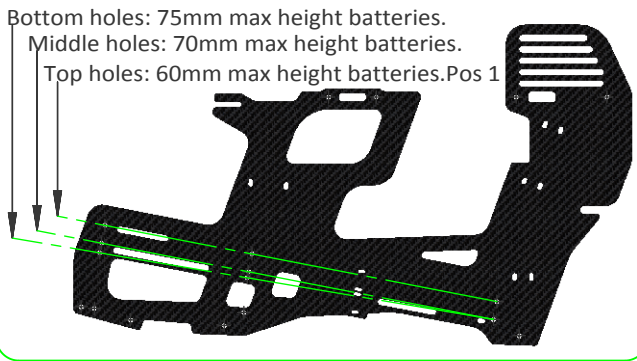

- Socket Head Cap Screw M3x10mm
-
- x3

- Finishing Washer M3
-
- x3

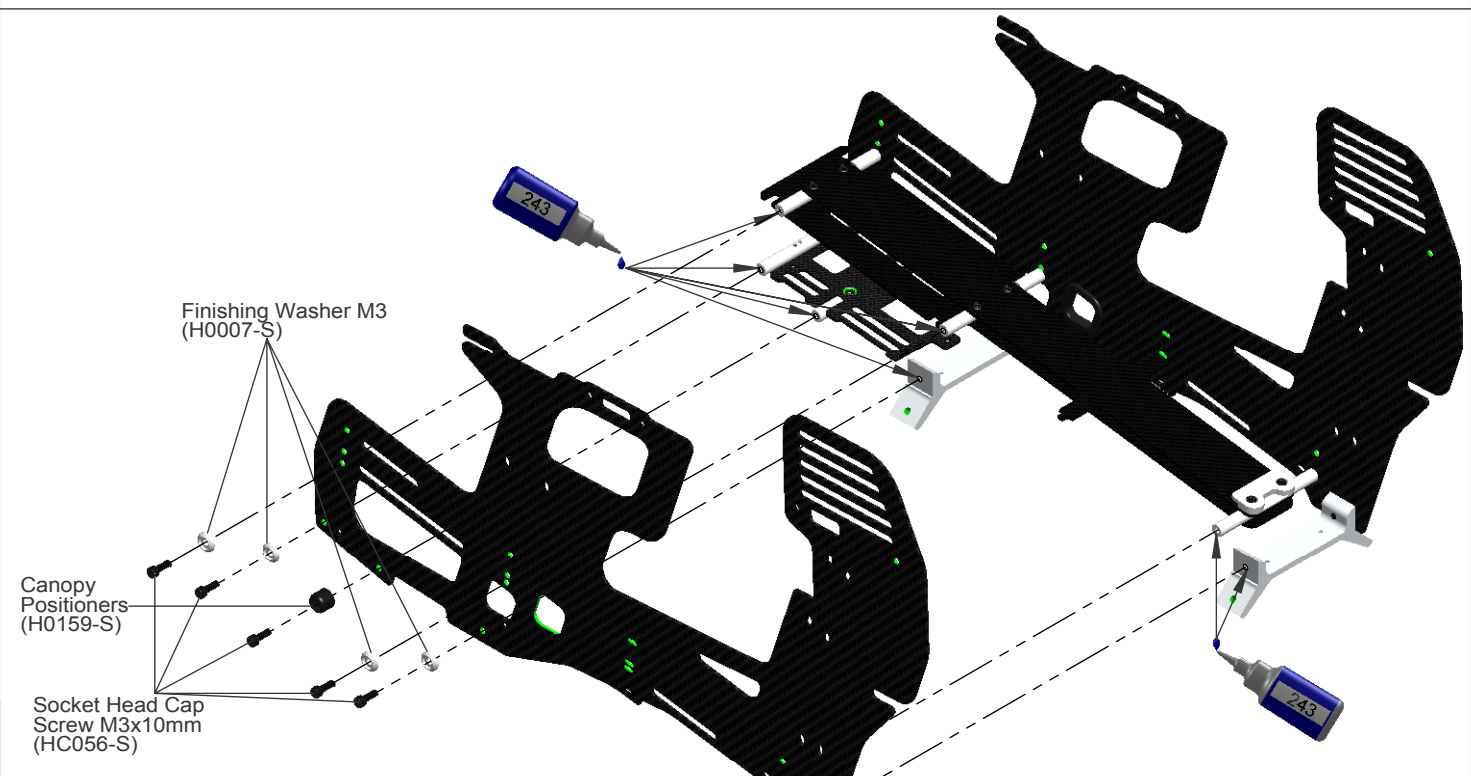

- Socket Head Cap Screw M3x10mm
-
- x7

- Finishing Washer M3
-
- x6

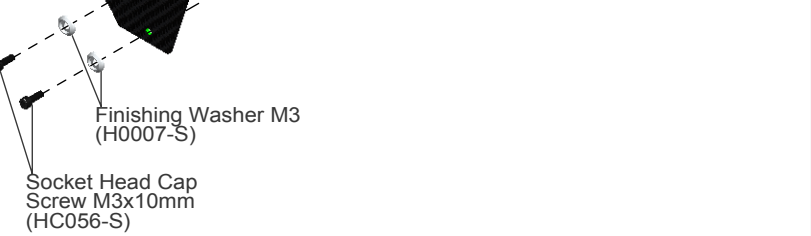



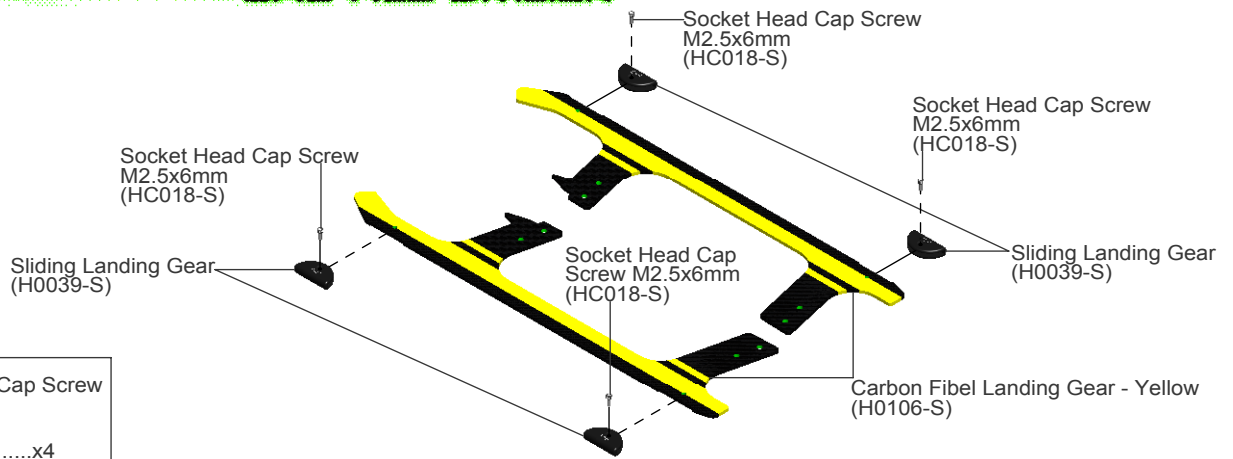

Box 6, Bag 2

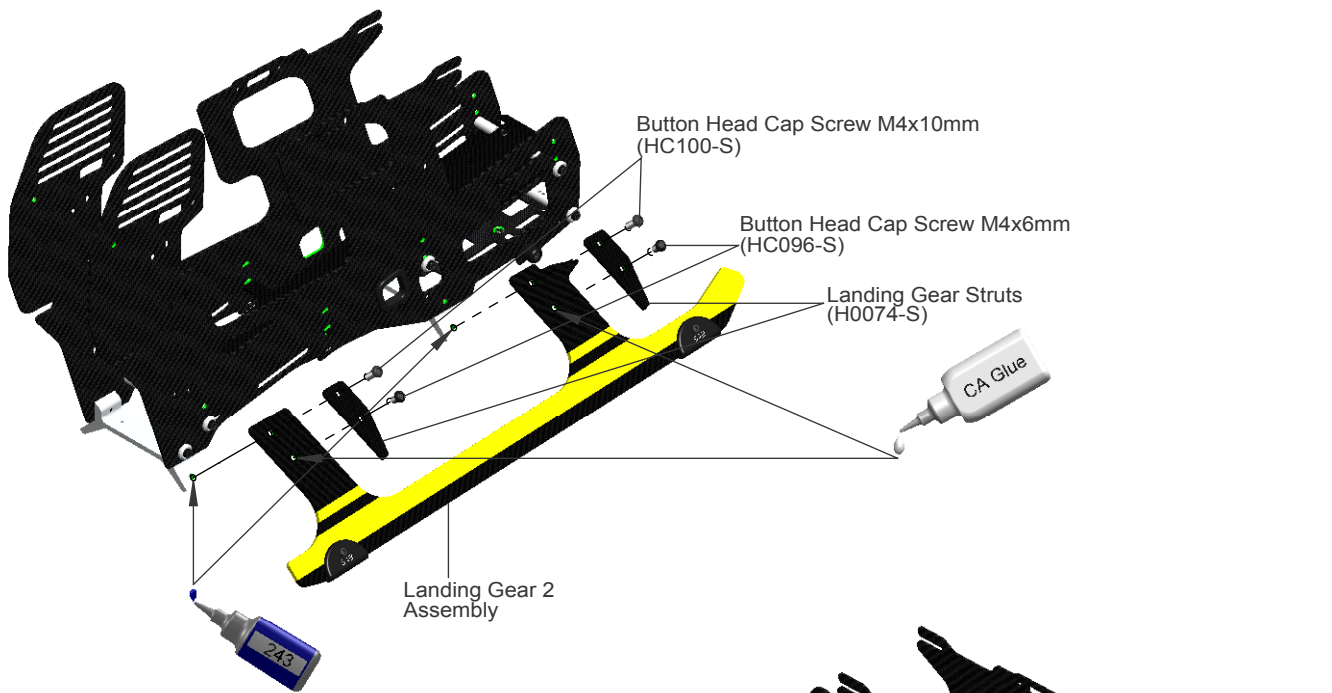

- Socket Head Cap Screw
M2.5x6mm
- 
-x4



- Button Head Cap Screw
M4x6mm
- 
-x4
- Button Head Cap Screw
M4x10mm
- 
-x4

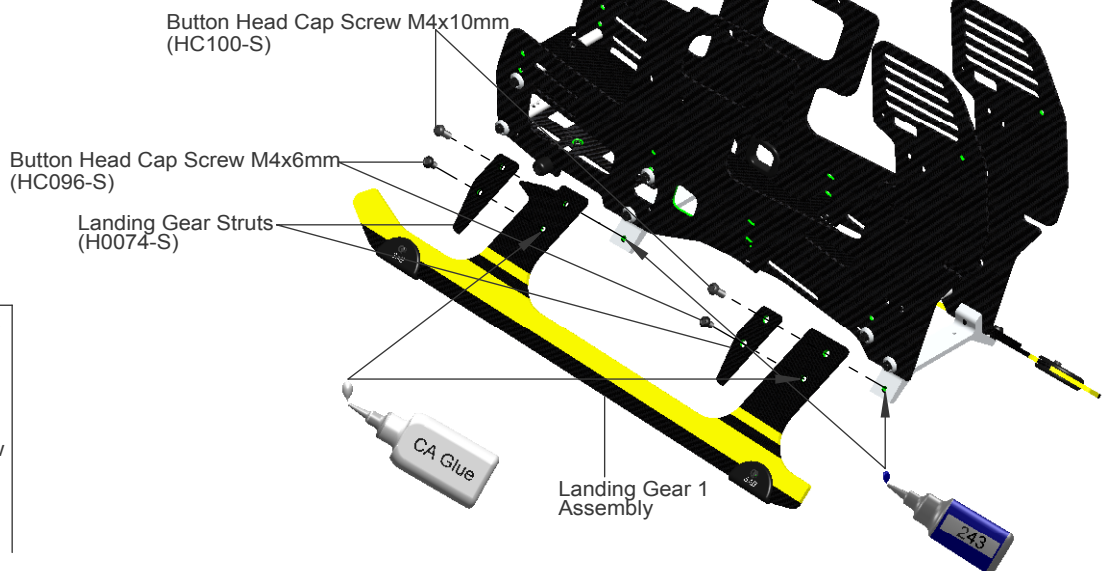



5 - Transmission Assembly

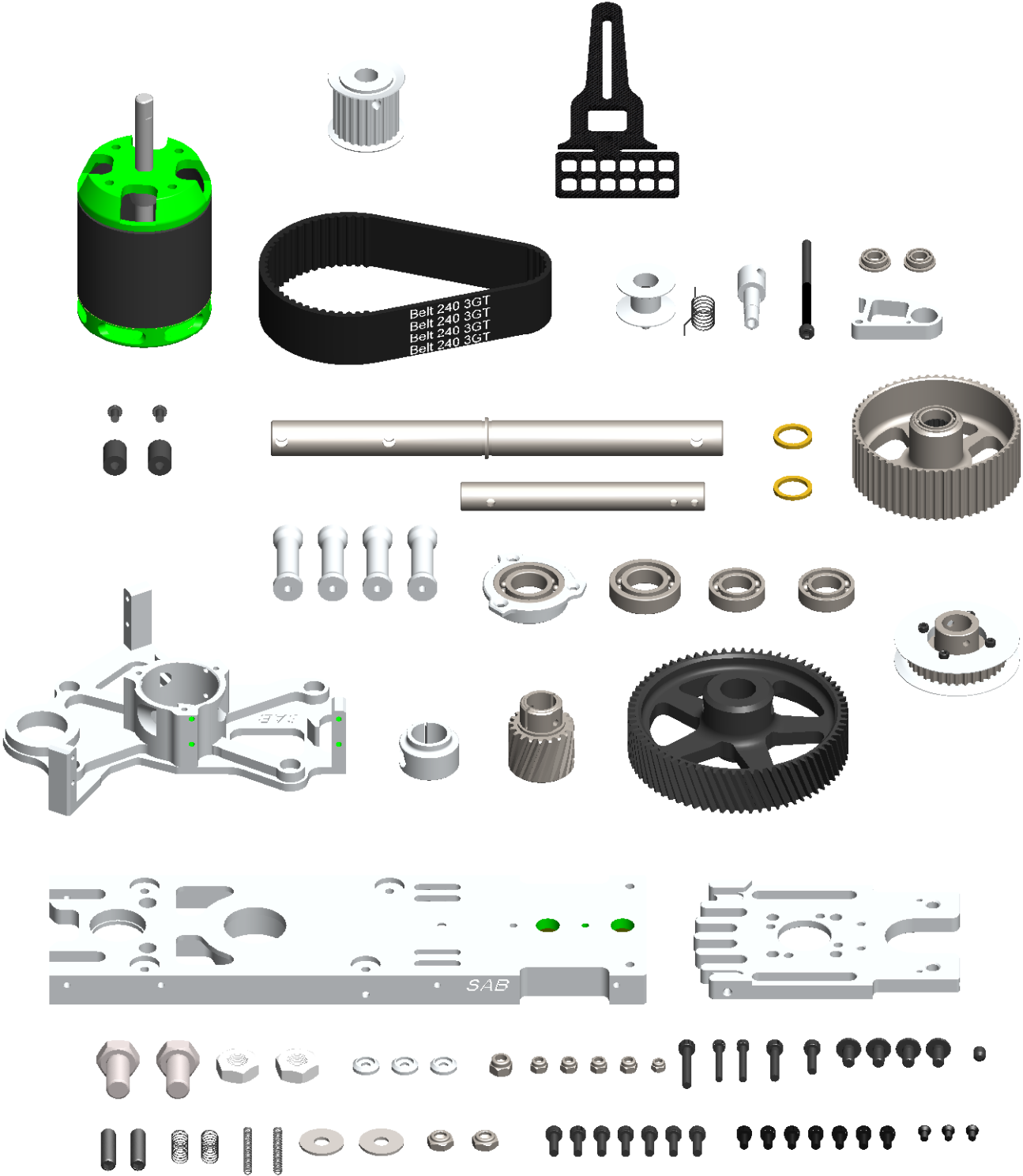



Box 6, Bag 3, Tray 3, Tray 4

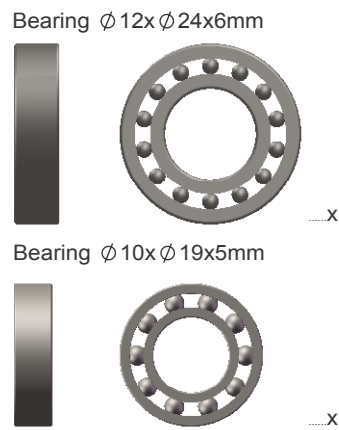
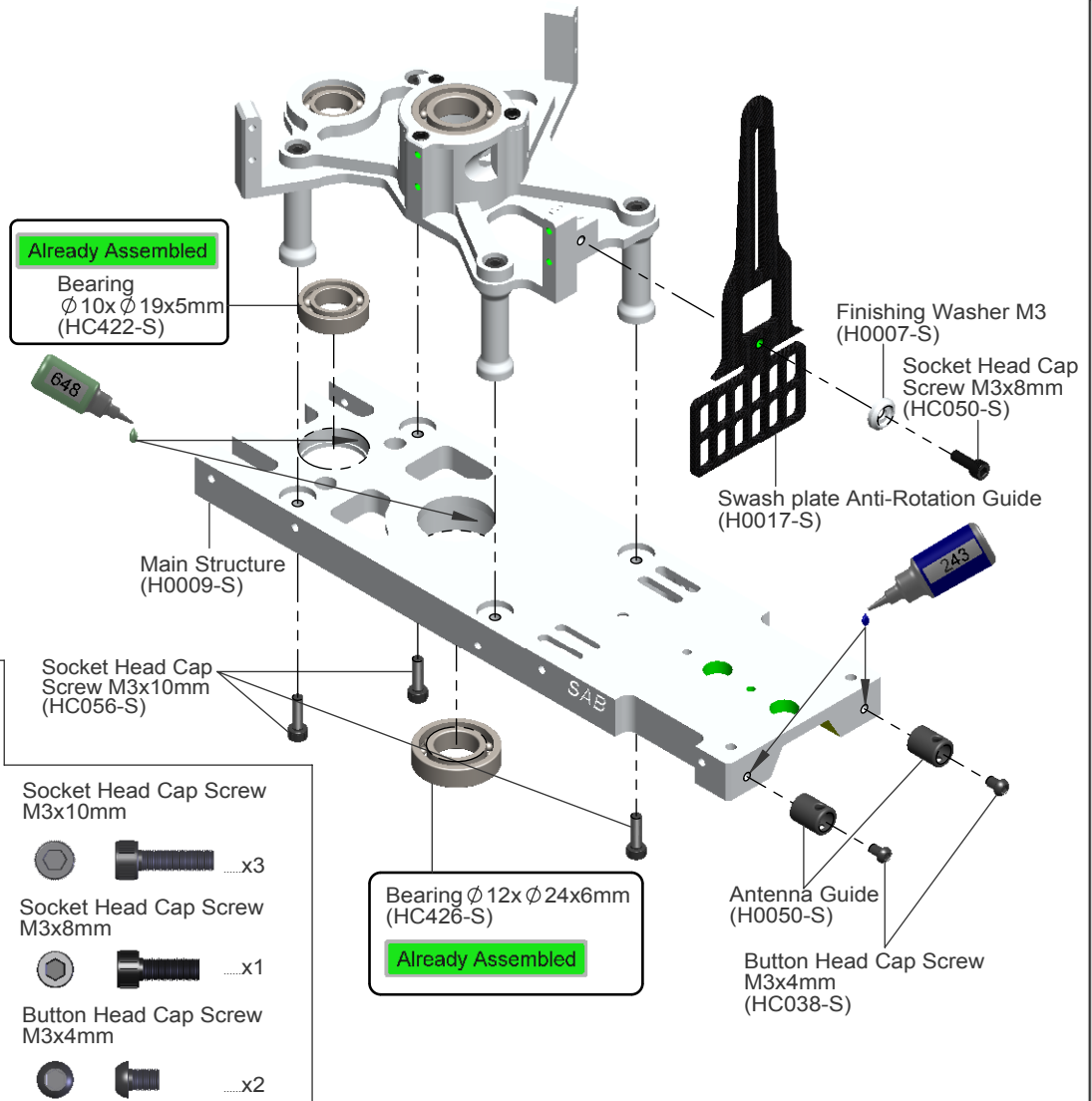
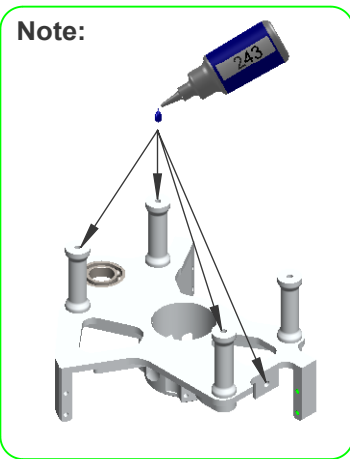
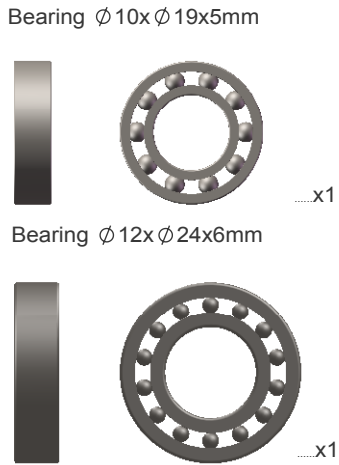
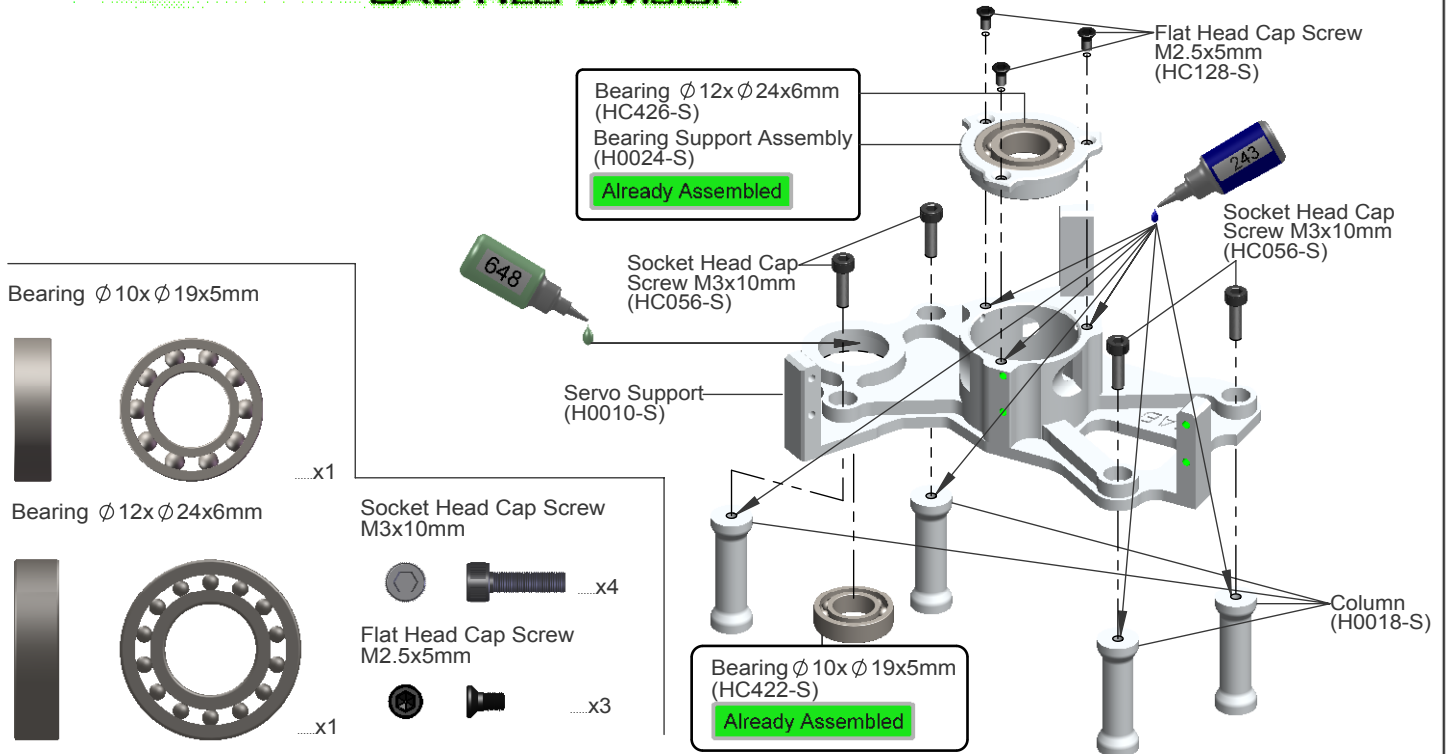



Bag 4, Tray 1, Tray 3

Note 1: When you tighten the collar (H0121-S) on the main shaft, ensure there is no axial play. Push down the main shaft while pulling up the locking collar. Tighten the screw M4x22 at this time.

Note 2:

The pinion and gear are designed to have zero backlash. This leads to initial "rough" rotation. After some run in flights (3-5 flights) it will begin to rotate freely, ensuring perfect contact and the ability to transmit maximum power. It is advisable to lubricate these two elements with a lubricant (Tri-Flow Synthetic grease).

Main Shaft (H0122-S)

Check the axial play See Note 1.

Metric Hex Nylon Nut M3 (HC206-S)

19T Drive Pinion (H0156-S)

68T Main Gear (H0012-S)

Metric Hex Nylon Nut M4 (HC212-S)

Socket Head Cap Screw Shouldered M3x18mm (HC079-S)

Note 2

Socket Head Cap Screw Shouldered M4x24mm (HC111-S)

Main Structure Assembly 1

Note: Correct insertion of the one-way pulley

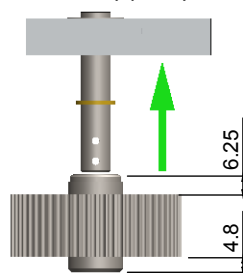

Secondary Shaft (H0157-S)

Metric Hex Nylon Nut M4 (HC212-S)

M4 Locking Collar (H0121-S)

Socket Head Cap Screw M4x22mm (HC104-S)

Metric Hex Nylon Nut M2.5

Socket Head Cap Screw Shouldered M2.5x19mm

Socket Head Cap Screw M4x22mm

Metric Hex Nylon Nut M4

Socket Head Cap Screw Shouldered M4x24mm

60T Pulley Assembly (H0171-S)

Already Assembled

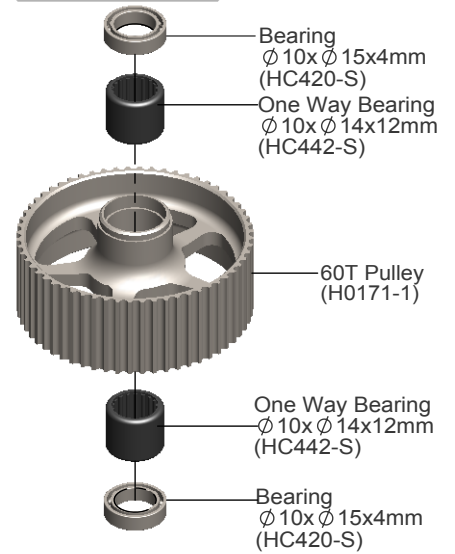

Front Tail Pulley Assembly (H0172-S)

Socket Head Cap Screw M2x12mm (HC014-S)

37T Pulley (H0172-S)

Bush One Way (H0110-S)

Washer $\phi 10x \phi 16x0.2mm$ (HC232-S)

The perfect play is 0.5mm add or remove shim for this

Metric Hex Nylon Nut M2.5 (HC200-S)

Front Tail Pulley Low Assembly (H0172-S)

Socket Head Cap Screw Shouldered M2.5x19mm (HC033-S)

Socket Head Cap Screw M2x5mm

Socket Head Cap Screw M2x5mm



Bag 5, Tray 3

Tail Belt Idler Assembly (H0174-S)

Already Assembled

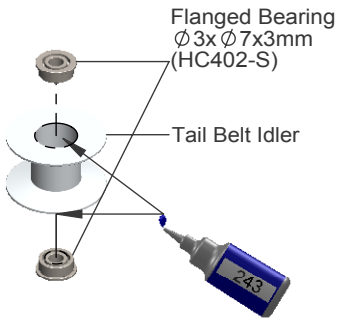

Belt Tensioner Arm Assembly (H0174-S)

Already Assembled

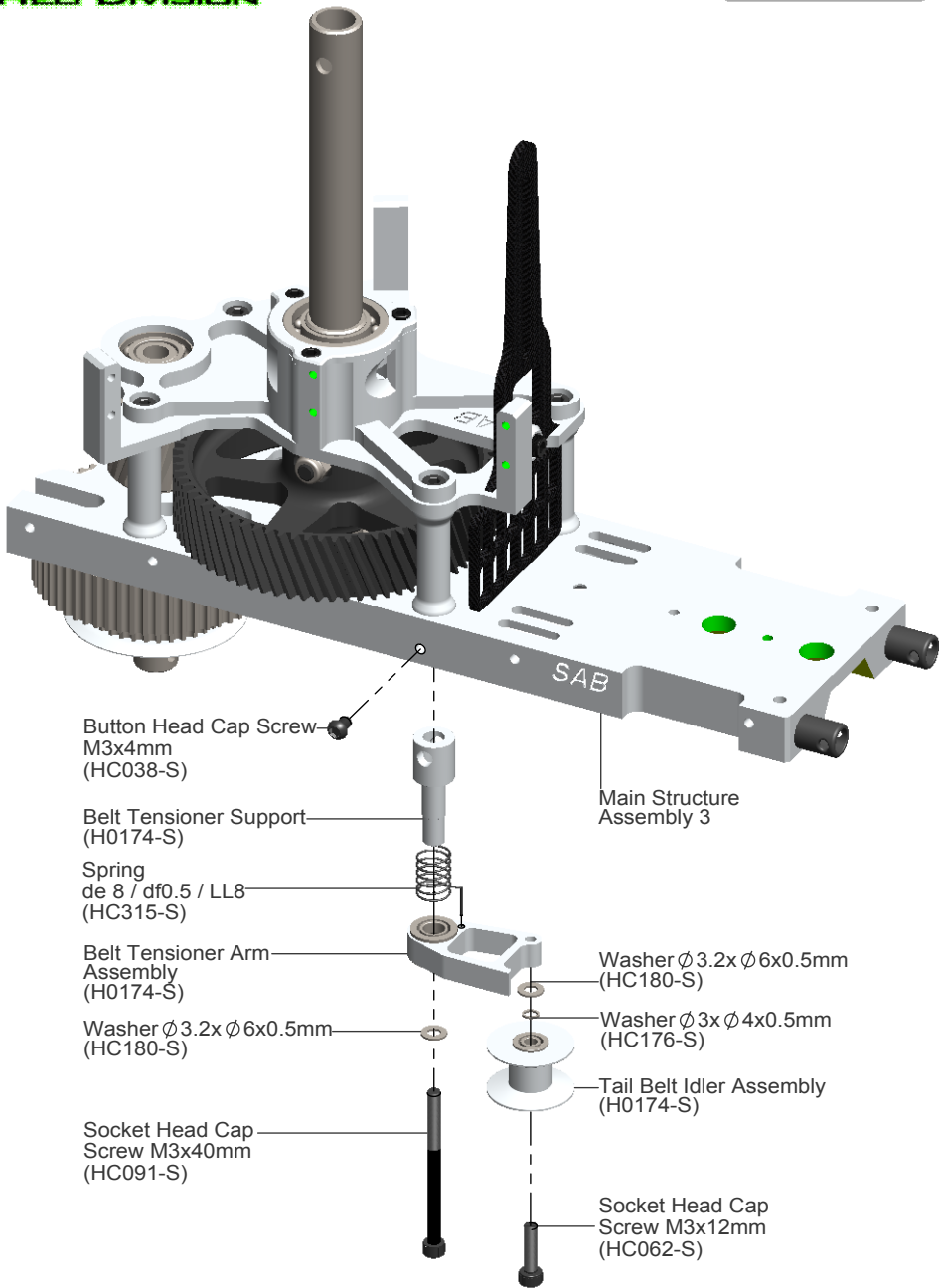
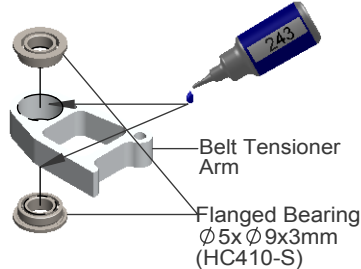

- Button Head Cap Screw M3x4mm (HC038-S)
- Belt Tensioner Support (H0174-S)
- Spring de 8 / df0.5 / LL8 (HC315-S)
- Belt Tensioner Arm Assembly (H0174-S)
- Washer $\varnothing 3.2 \times \varnothing 6 \times 0.5$ mm (HC180-S)
- Washer $\varnothing 3 \times \varnothing 4 \times 0.5$ mm (HC176-S)
- Tail Belt Idler Assembly (H0174-S)
- Socket Head Cap Screw M3x40mm (HC091-S)
- Socket Head Cap Screw M3x12mm (HC062-S)
- Main Structure Assembly 3

Button Head Cap Screw M3x4mm



Socket Head Cap Screw M3x12mm



Socket Head Cap Screw M3x40mm



Flanged Bearing $\varnothing 5 \times \varnothing 9 \times 3$ mm



Flanged Bearing $\varnothing 3 \times \varnothing 7 \times 3$ mm



Washer $\varnothing 3 \times \varnothing 4 \times 0.5$ mm

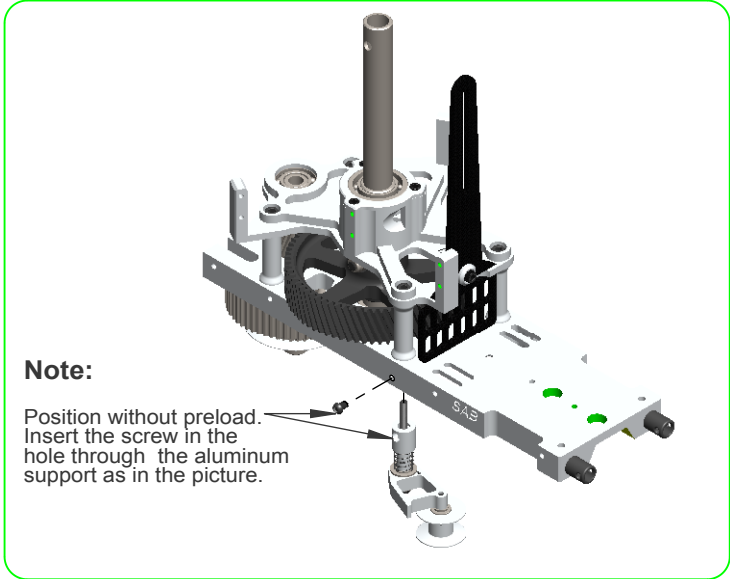

Note:

Position without preload. Insert the screw in the hole through the aluminum support as in the picture.



SAB HELI DIVISION

Bag 6, Tray 3, Tray 4

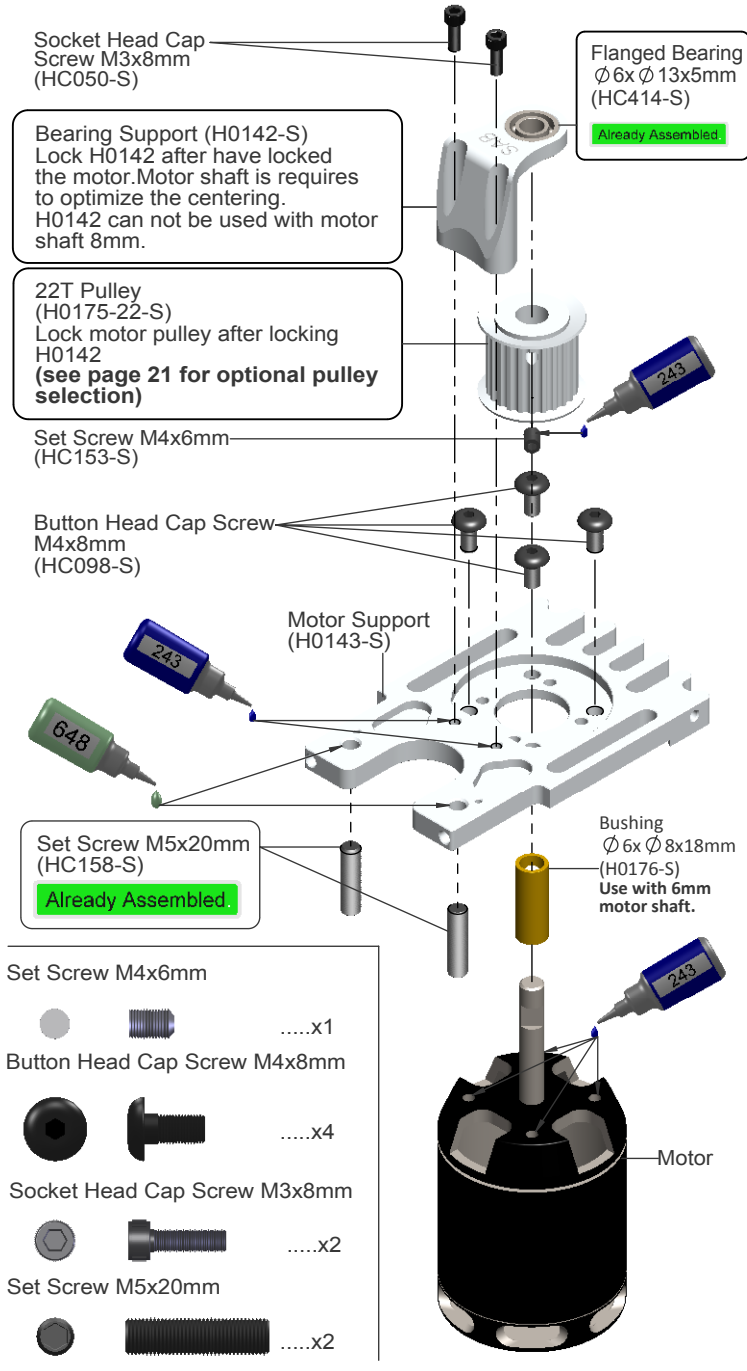

- Set Screw M4x6mmx1
- Button Head Cap Screw M4x8mmx4
- Socket Head Cap Screw M3x8mmx2
- Set Screw M5x20mmx2

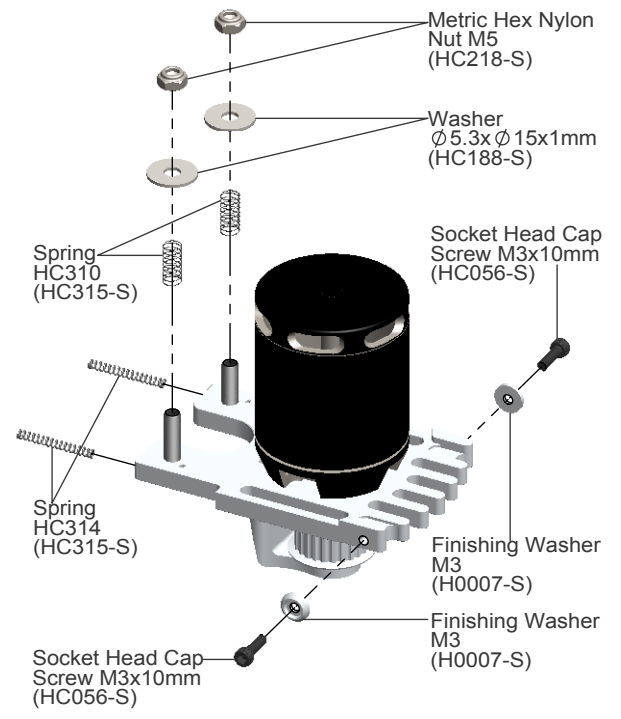

- Finishing Washer M3x2
- Socket Head Cap Screw M3x10mmx2
- Washer $\varnothing 5.3 \times \varnothing 15 \times 1 \text{mm}$ x2

Note for 6mm motor shaft

To maximize space for the batteries, it is advisable to shorten the motor shaft. Follow the dimensions given in this drawing. For the cut, you can use an electric tool like a "Dremel" with a cut-off disc.

Additionally, ensure the motor shaft has an appropriate 'flat' for one of the set screws.

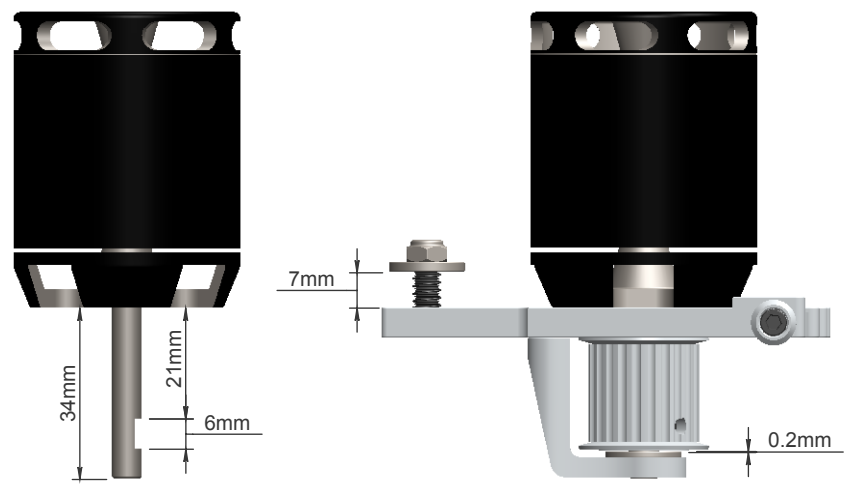



6 - Main Rotor

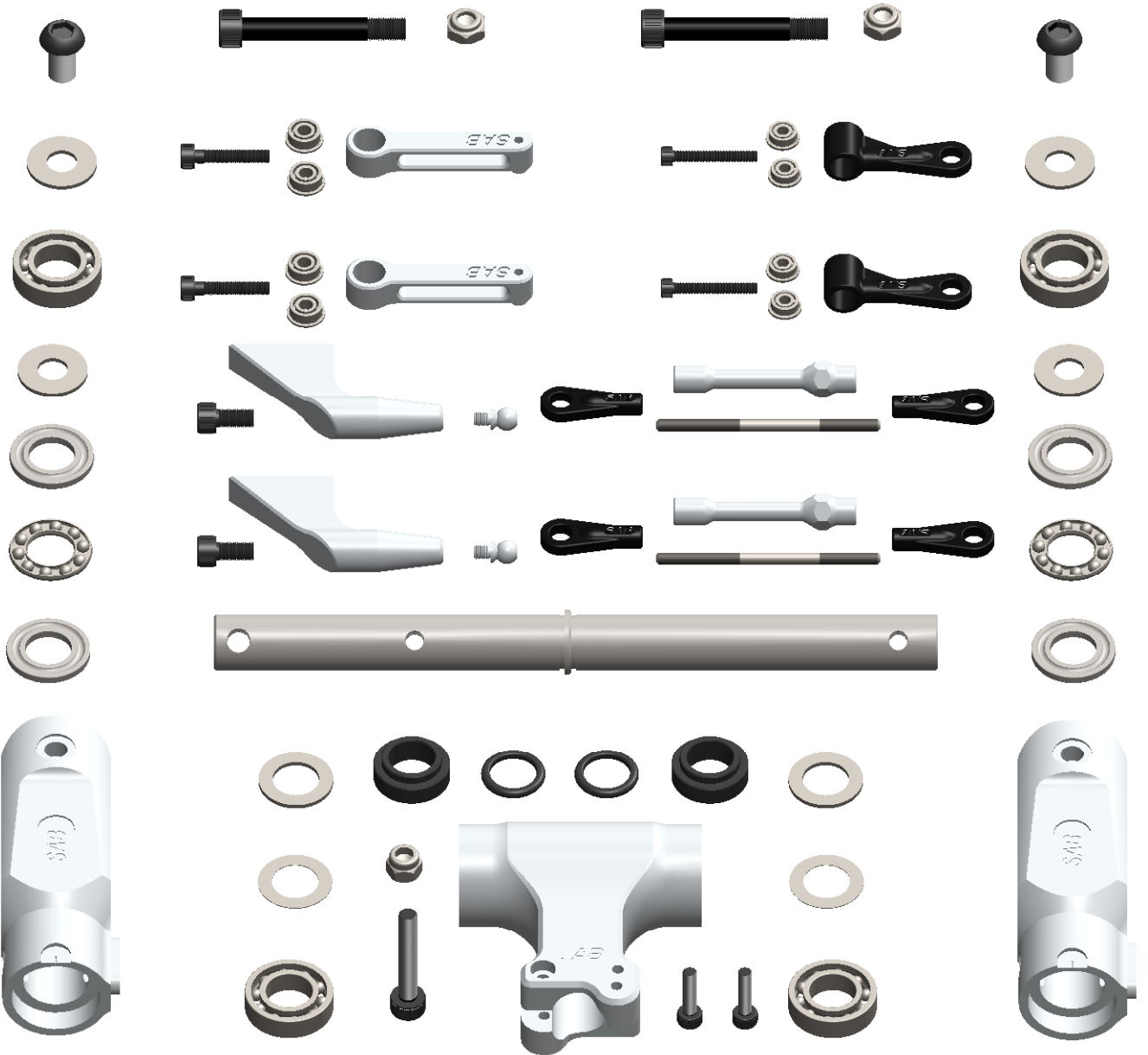



Bag 7, Tray 1

Uniball Radius Arm... x2 Assembly

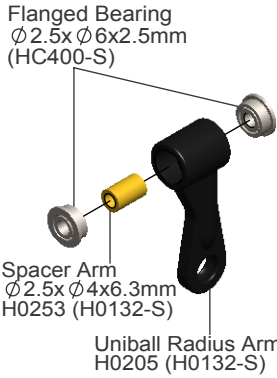

Radius Arm ... x2 Assembly

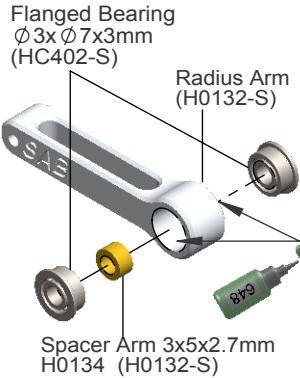

Center Hub Assembly

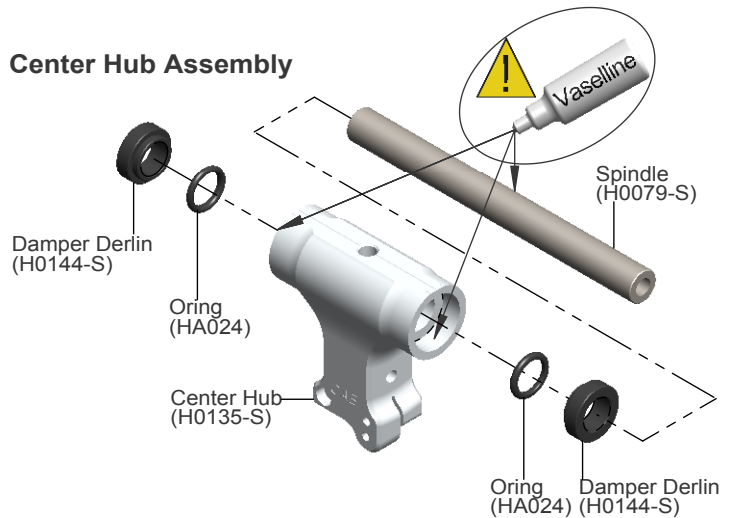

Note:

The main rotor is assembled provisionally without loctile. Need to add Loctile 243 in the screws M4x10 and M6x10.

Swashplate Assembly

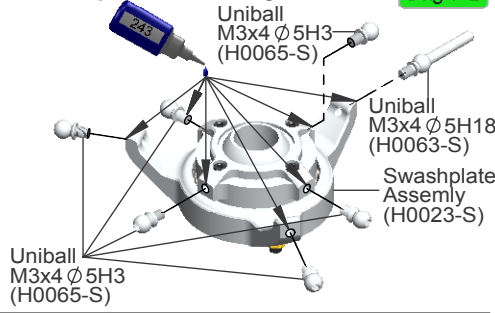

Main Blade Grip Assembly...x2

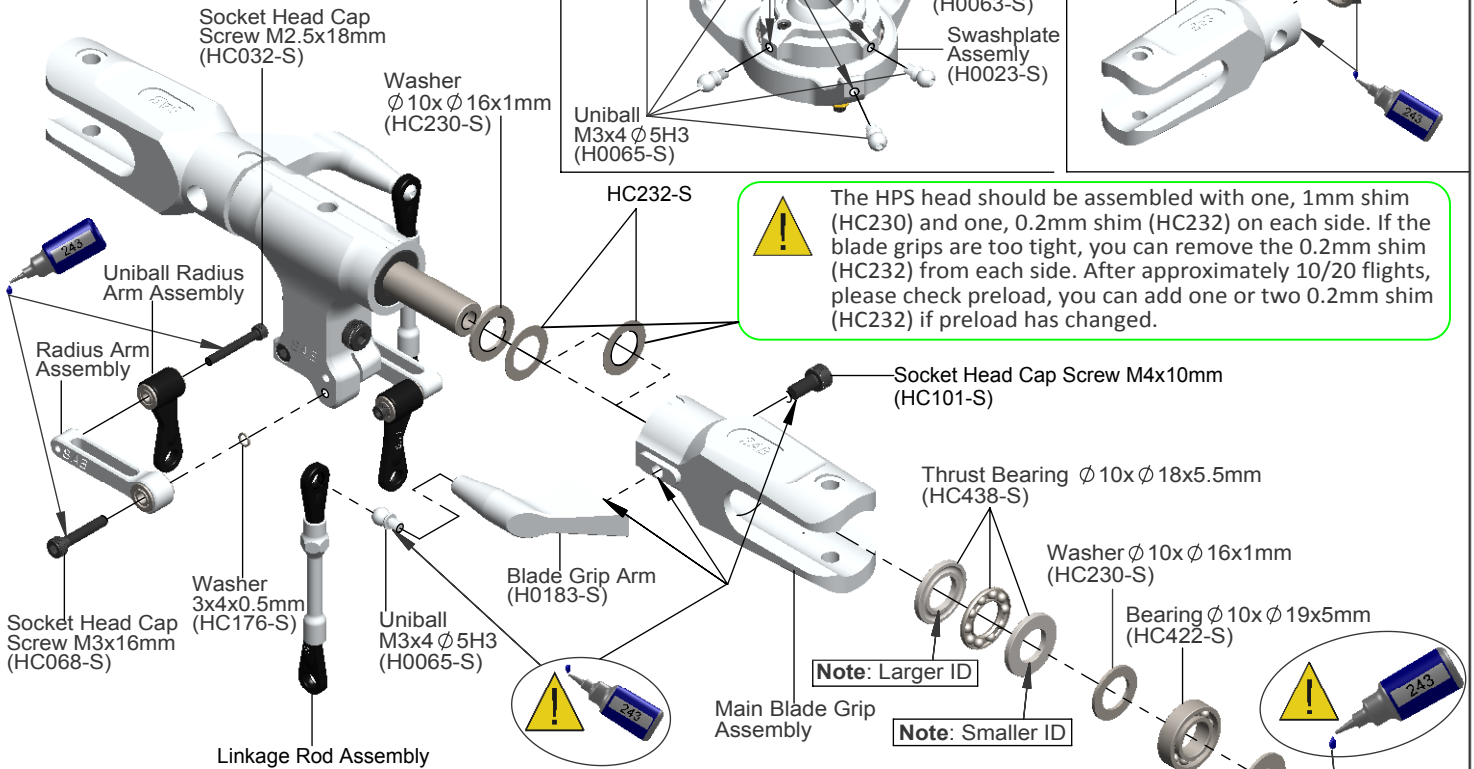
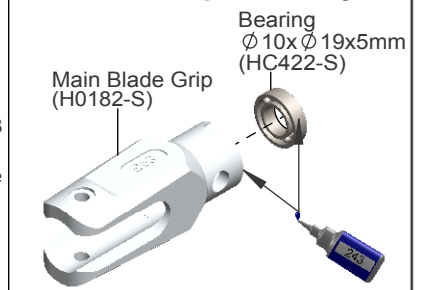

The HPS head should be assembled with one, 1mm shim (HC230) and one, 0.2mm shim (HC232) on each side. If the blade grips are too tight, you can remove the 0.2mm shim (HC232) from each side. After approximately 10/20 flights, please check preload, you can add one or two 0.2mm shim (HC232) if preload has changed.

Linkage Rod A Assembly ...x2

Bag 7-3

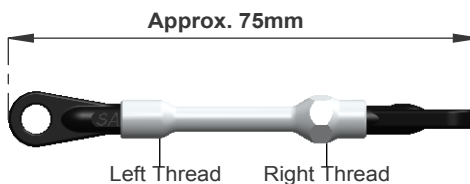
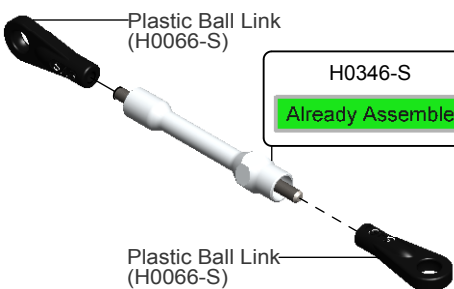

(Initial length for the rods from the swash plate to the Blade Grip.)

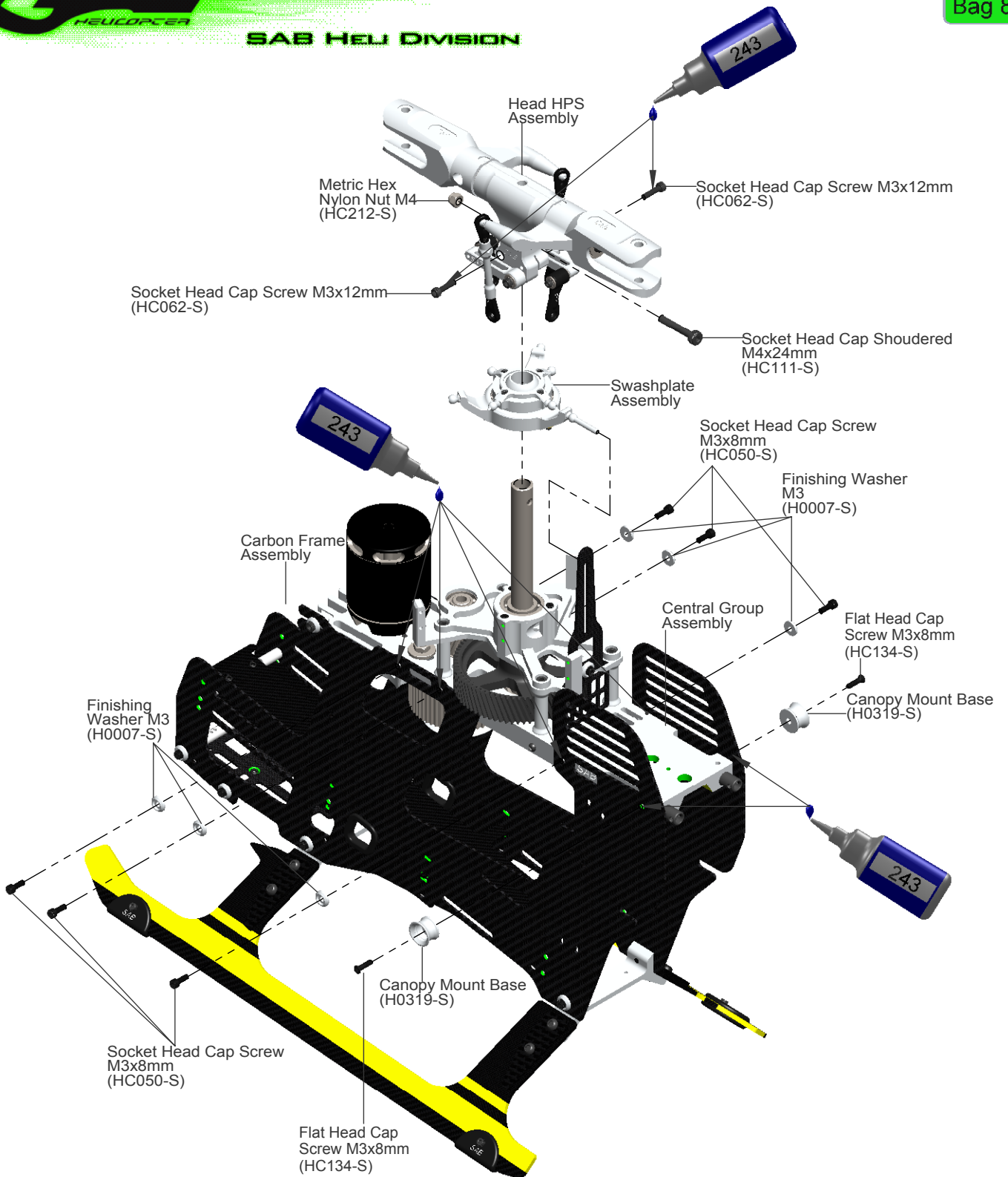

- | | |
|---|--|
|   <p>.....x6</p> |   <p>.....x6</p> |
|   <p>.....x2</p> |   <p>.....x1</p> |
|   <p>.....x1</p> | |



INSTALLATION OF SWASHPLATE SERVOS

The linkage ball must be positioned between **17-19 mm** out on the servo arm (**figure 1**). The 120° placement of the servos inside Goblin means the arms are difficult to access. For this reason it is advisable to ensure alignment of the servo arms (and sub trim set) before installation of the servos in the model (**figure 2**). Proceed with installation following the instructions below. **Figure 3** shows a completed installation.

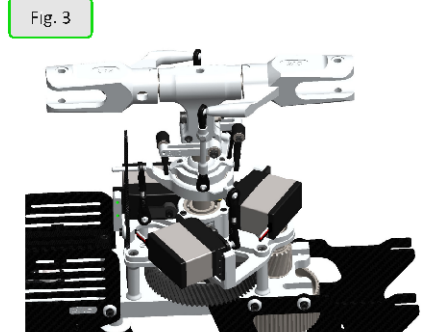
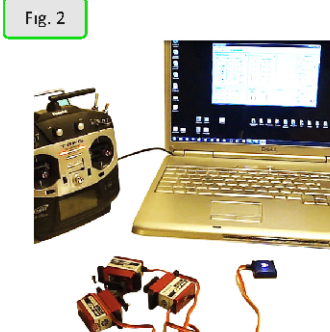
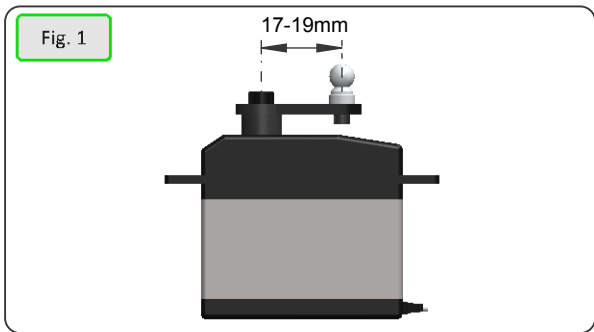

ASSEMBLY OF THE BALL ON THE HORN.

The rods going from the servos to the swash plate must be as vertical as possible. Not all servos are equal, so to better align them you can choose to use the supplied spacer H0031. Figure 4 illustrates this.

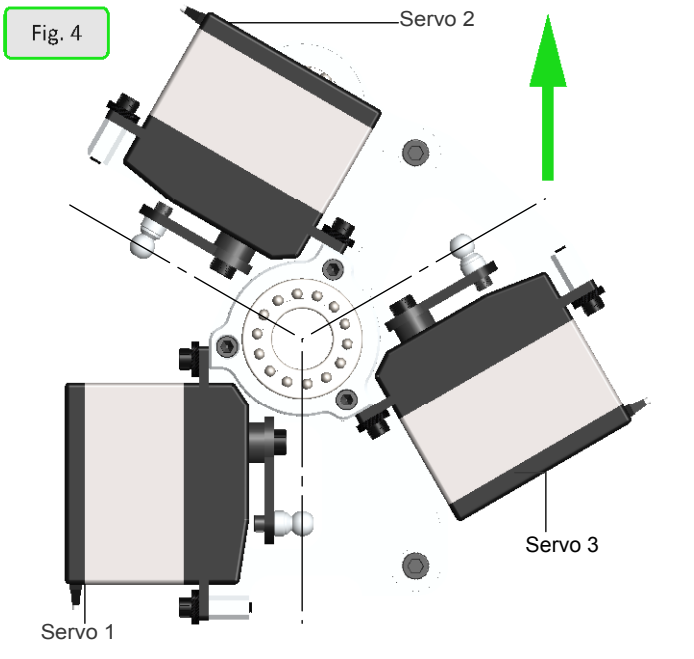

SERVO ASSEMBLY 1, 2, 3

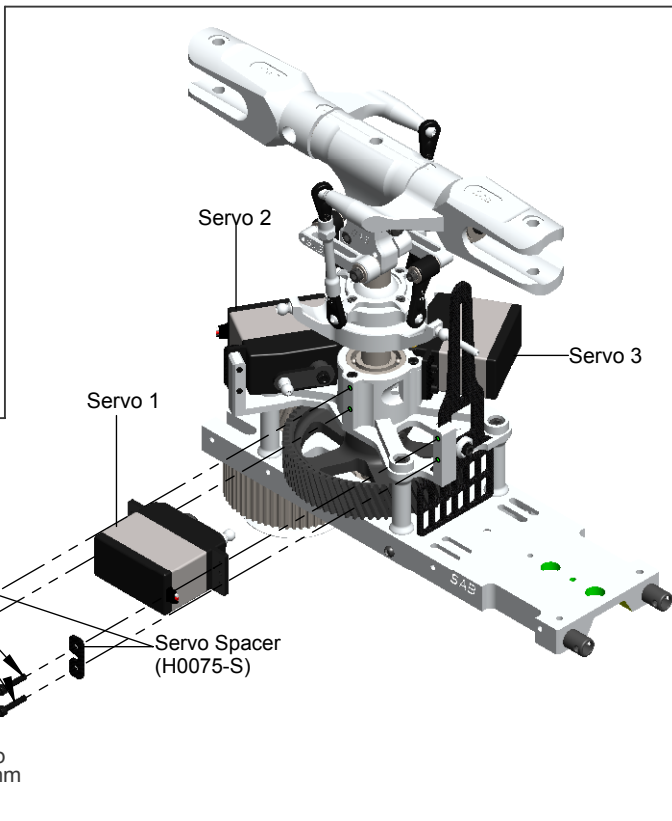
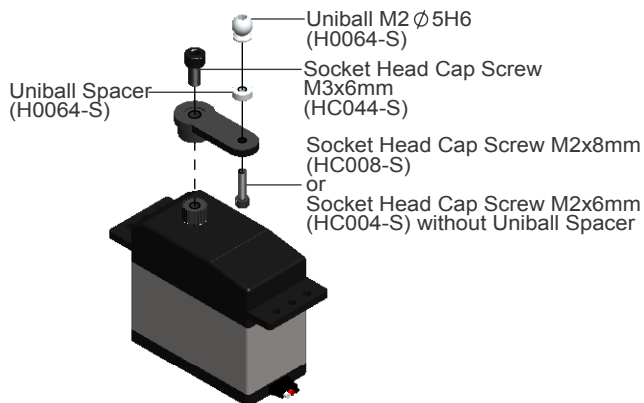

- Socket Head Cap Screw M2.5x8mm x3
- Socket Head Cap Screw M2.5x12mm x9

- Socket Head Cap Screw M2.5x8mm (HC020-S)
- Socket Head Cap Screw M2.5x12mm (HC026-S)
- Servo Spacer (H0075-S)



The wire for the front servo must be positioned here

Fig. 5

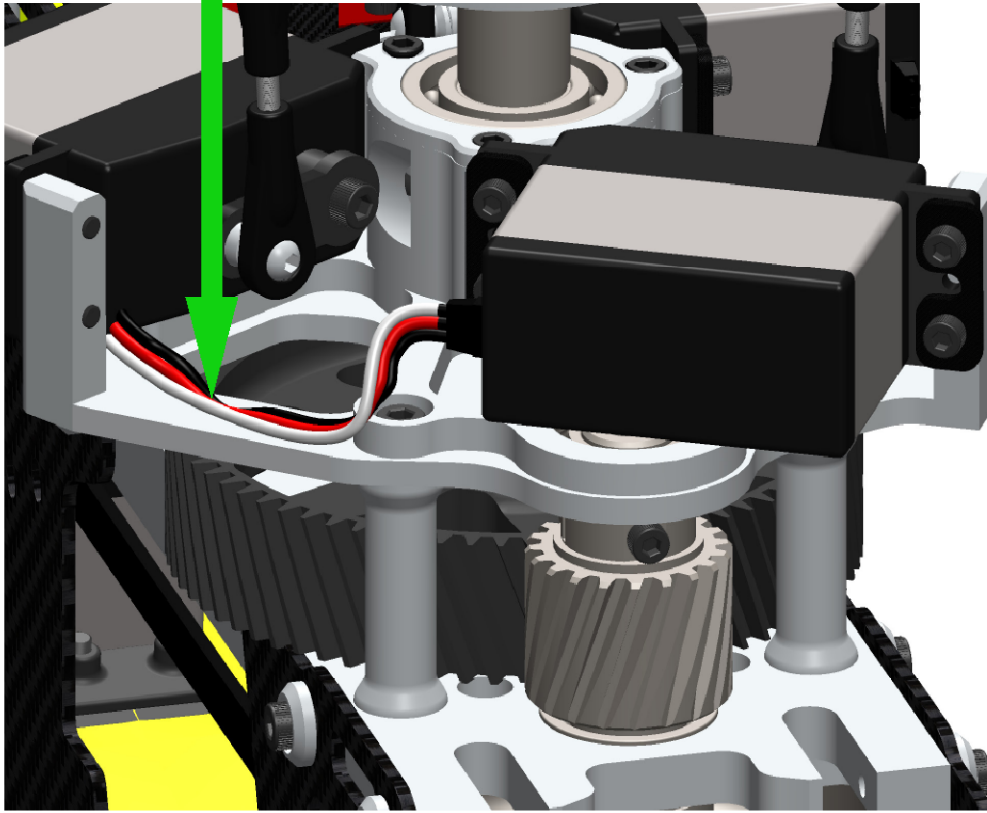

Head HPS Version Preliminary Setup

Adjust the linkage as shown. The linkage Rod A has thread right/left. Turning, you can change the tracking without disconnecting the plastic ball link.

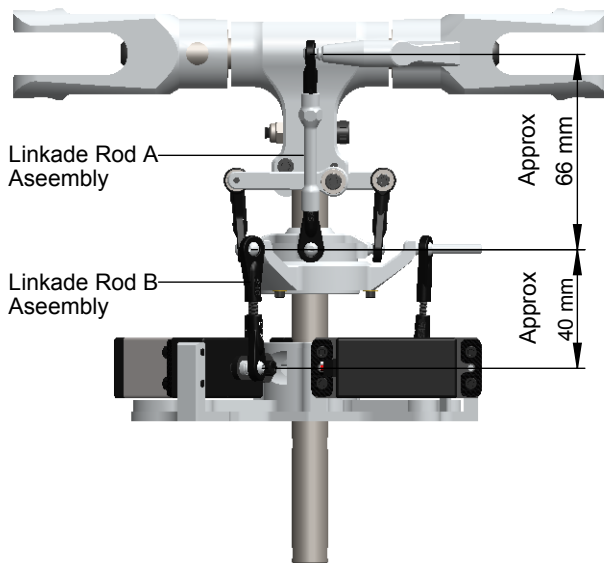

Linkage Rod A Assembly ... x2

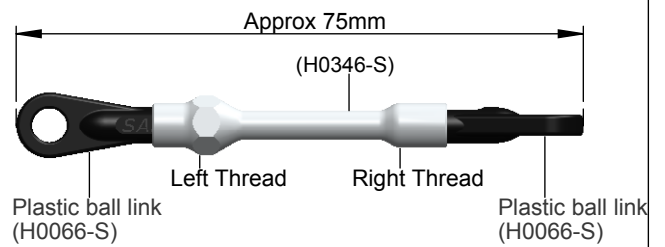

Initial length for the rods from the swashplate to the blade grips.

Linkage Rod B Assembly ... x3

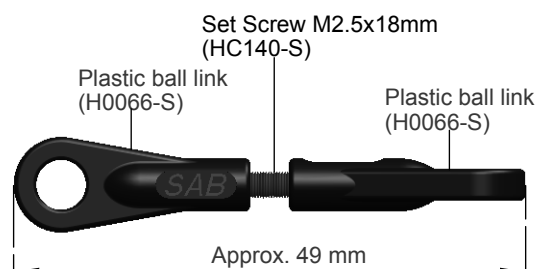

Initial length for the rods from the servos to the swash plate.



DE-BURR THE SIDE FRAMES

We recommend de-burring the edges of the carbon parts in areas where electrical wires run.



ESC INSTALLATION

The speed controller (ESC) is installed in the front of the helicopter.
 Figure 1 shows the mounting area. Figure 2 shows the installation of the Kosmik ESC from Kontronik.
 You can also use the heat sink (H0165-S) if you wish for improved cooling (Figure 3,4,5)

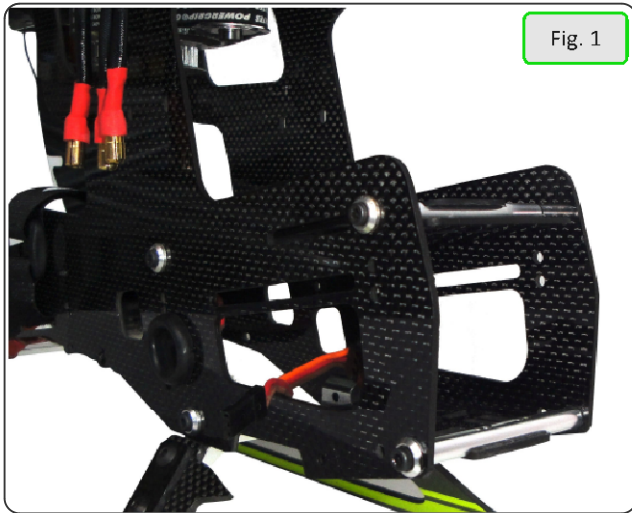

Fig. 1

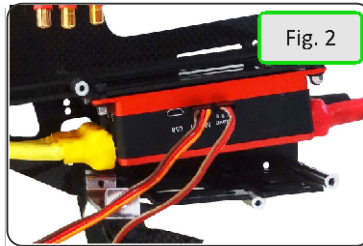

Fig. 2

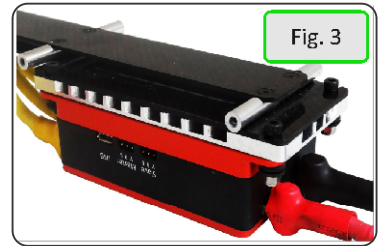

Fig. 3

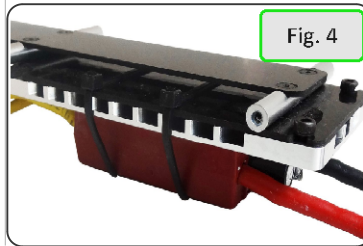

Fig. 4

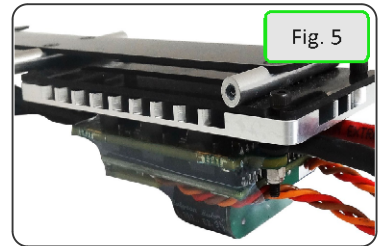

Fig. 5

Figure 6: Shows the wiring which connects the receiver and ESC (in this picture one frame has been removed).
 If the BEC used is combined with the ESC, it is recommended to use a dual wire connection.

Figure 7: The passage of the controller wires to the motor is highlighted.

Figure 8: Shows the installation of a 2S battery for the flight control system.
 Alternatively, a BEC could be placed in the same area.

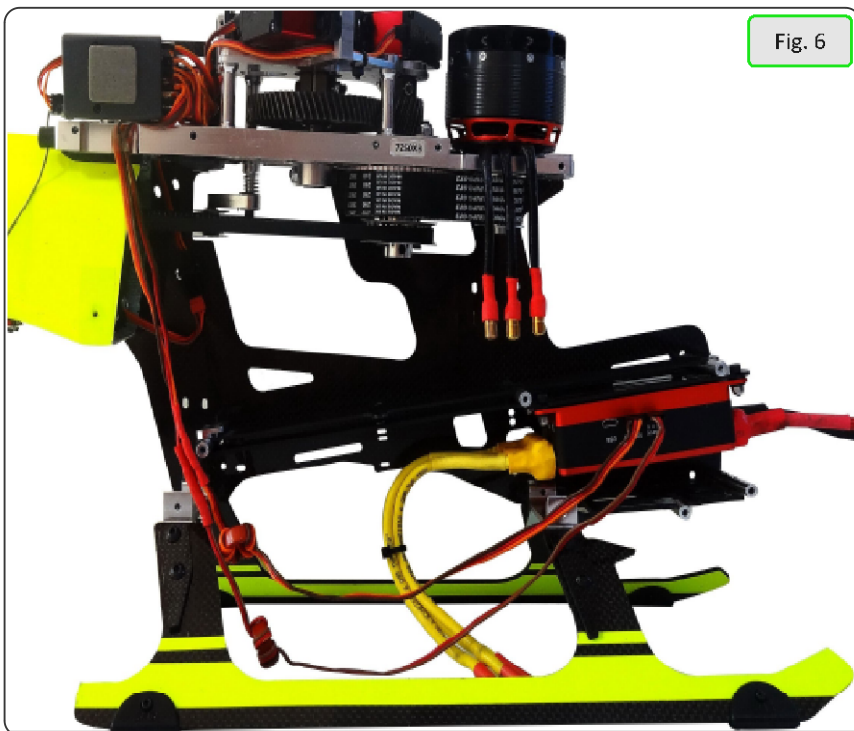
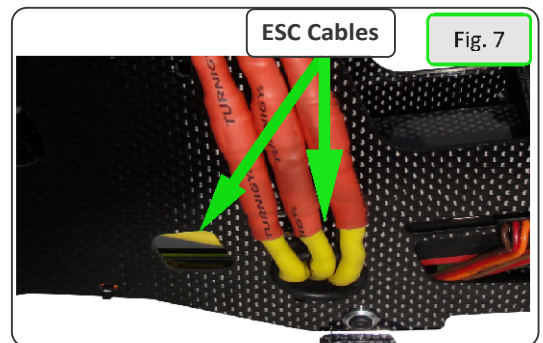

Fig. 6



ESC Cables

Fig. 7

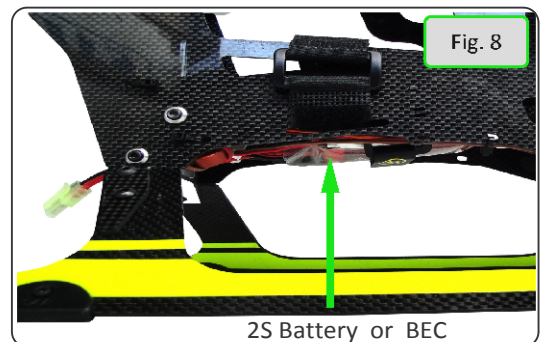

Fig. 8

2S Battery or BEC

FLYBARLESS CONTROL UNIT AND RX INSTALLATION

It is possible to install any commercially available Flybarless control unit in the goblin.

For Flybarless systems with a separate sensor, the sensor must be installed under the plate (Figure 1).

Figure 2 shows an example of installation of the receiver and flybarless control unit.

In Figure 3 you can see the extension lead for the tail servo. It is very important to include a connector for fast disassembly of the boom module. The connector will prevent servo damage in case of boom separation during a crash.

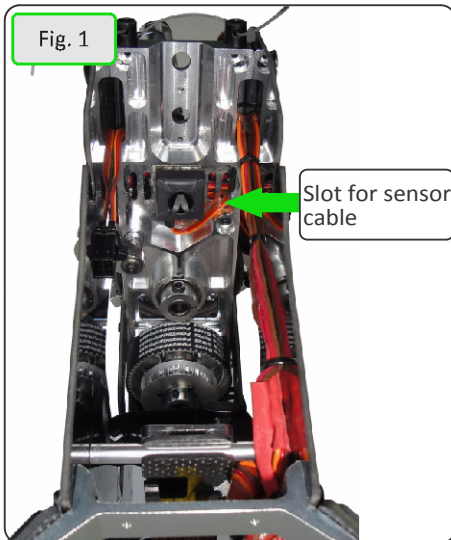

It is important to lock the plugs of the flybarless unit with an adhesive - for example hot glue.

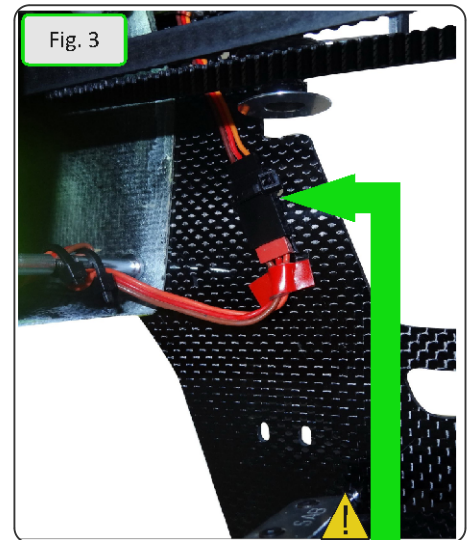

Tail servo extension cable

To install a one piece Flybarless system it is necessary to add the support shown in these figures. Figure 3 shows the installed support. Figure 4 shows the control unit and the receiver installed on the support.

Bag 18

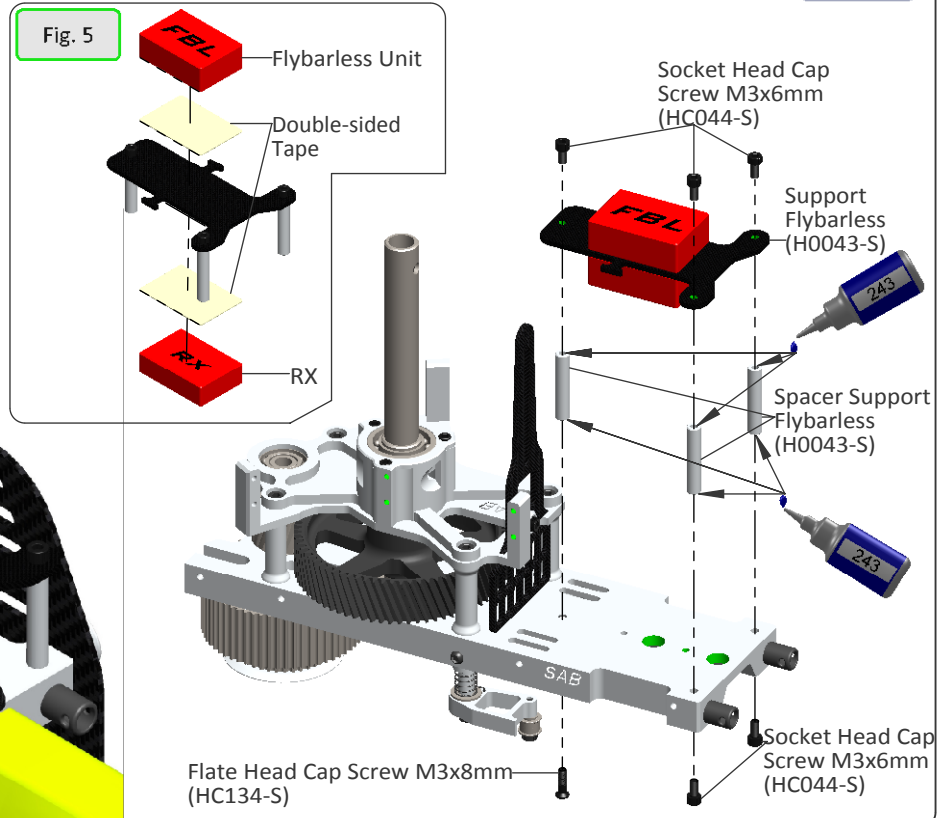
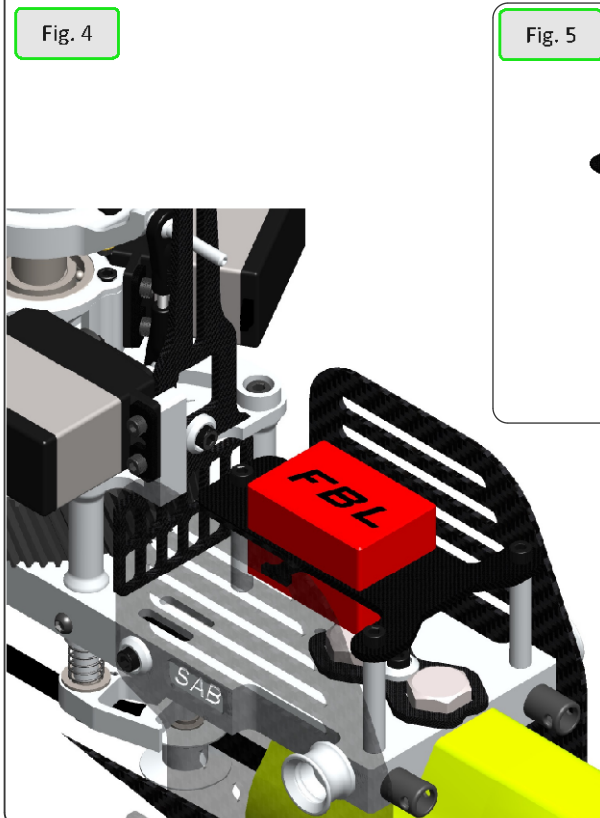



TRANSMISSION SETUP

It is important to choose the right reduction ratio to maximize efficiency based on your required flight performance. The Goblin has many possible reduction ratios at your disposal. It is possible to optimize any motor and battery combination. It is recommended to use wiring and connectors appropriate for the currents generated in a helicopter of this class.

If you are using a head speed calculator which requires a main gear and pinion tooth count, use **214** teeth for the main gear (this takes into account the two stage reduction) and the tooth count of your pulley as the pinion count.

Below is a list of available reduction ratios:

H0175-18-S - 18T Pinion = ratio 11.9:1	H0175-22-S - 22T Pinion = ratio 9.8:1
H0175-19-S - 19T Pinion = ratio 11.3:1	H0175-23-S - 23T Pinion = ratio 9.3:1
H0175-20-S - 20T Pinion = ratio 10.7:1	H0175-24-S - 24T Pinion = ratio 8.9:1
H0175-21-S - 21T Pinion = ratio 10.2:1	H0175-26-S - 26T Pinion = ratio 8.6:1

Some example configurations:

GOBLIN 700 COMPETITION CONFIGURATIONS

Rev:01

Performace	Battery	Motor	ESC	Pinion	RPM Max (Gov)	Pitch
GENERAL	12S 5000/5500	Quantum 4530-500	Edge 160 HV (V2)	22T	2100	± 12,5
			Jive 120 HV YGE 160 HV	21T	2100	± 12,5
		Kontronik Pyro 700-520	Edge 160 HV (V2)	22T	2100	± 12,5
			Jive 120 HV YGE 160 HV	20T	2100	± 12,5
3D	12S 5000/5500	Scorpion HK 4525-520	Edge 160 HV (V2)	23T	2250 ⚠	± 12,5
			Jive 120 HV YGE 160 HV KOSMIK 160/200	22T	2250 ⚠	± 12,5
		Quantum 4530-500	Edge 160 HV (V2)	23T	2250 ⚠	± 12,5
			Jive 120 HV YGE 160 HV KOSMIK 160/200	22T	2250 ⚠	± 12,5
		Kontronik Pyro 800-48	Jive 120 HV YGE 160 HV KOSMIK 160/200	24T	2250 ⚠	± 12,5
		14S 4500	Kontronik Pyro 800-48	YGE 160 HV KOSMIK 160	20T	2300 ⚠
	Scorpion 4530-450 Quantum 4530-450		YGE 160 HV KOSMIK 160	21T	2300 ⚠	± 12,5

Note: Although the Goblin can fly at high rpm, for safety reasons we suggest to not exceed 2200 rpm.



MOTOR BELT TENSION

- *Assemble the motor and pinion to its mounting plate.
- *Fit the motor assembly into position.
- *Compress the springs by pushing the motor toward the main shaft.
- *At maximum compression, temporarily tighten one of the slide screws.
- *With the minimum centre distance it is easy to install the belt. First put the belt on the motor pinion.
- *Then put the belt around the big pulley.
- *Rotate the motor several times by hand.
- *Release the screw that locks the slide.
- *The springs keep the belt in tension.
- *Help the springs by pulling the motor slightly.
- ***The belt must be very tight.**
- *Lock all screws.

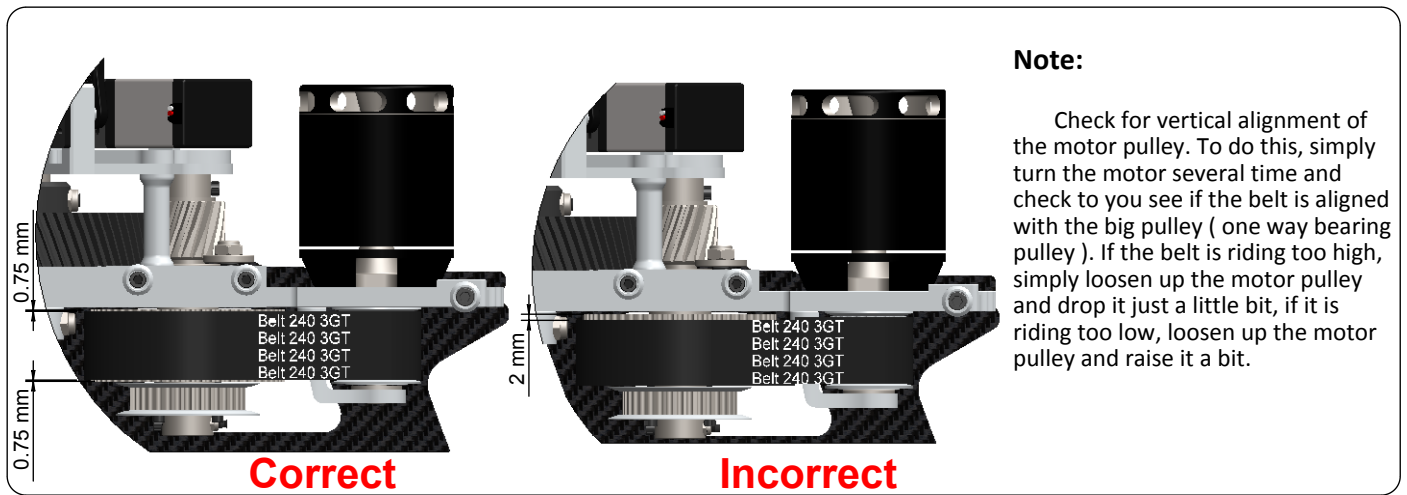

Note:
Check for vertical alignment of the motor pulley. To do this, simply turn the motor several times and check to see if the belt is aligned with the big pulley (one way bearing pulley). If the belt is riding too high, simply loosen up the motor pulley and drop it just a little bit, if it is riding too low, loosen up the motor pulley and raise it a bit.

Fig 1:

Figure 1 shows the motor correctly wired. It is advisable to cover the wire joints between the motor and the ESC with heat shrink tubing.

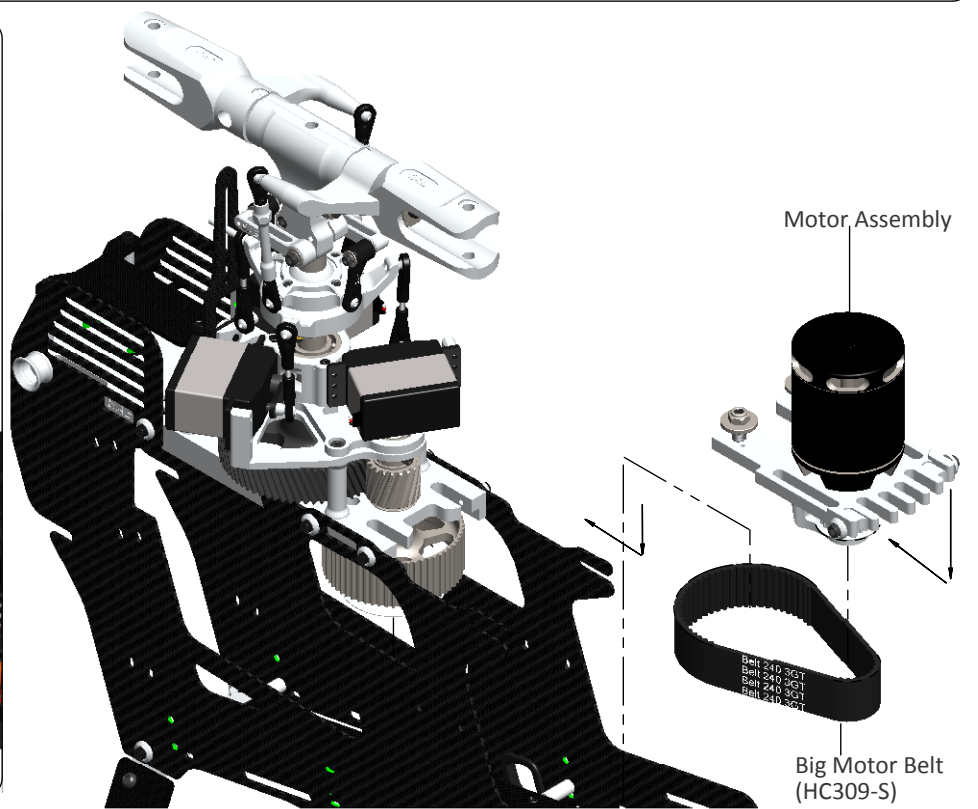
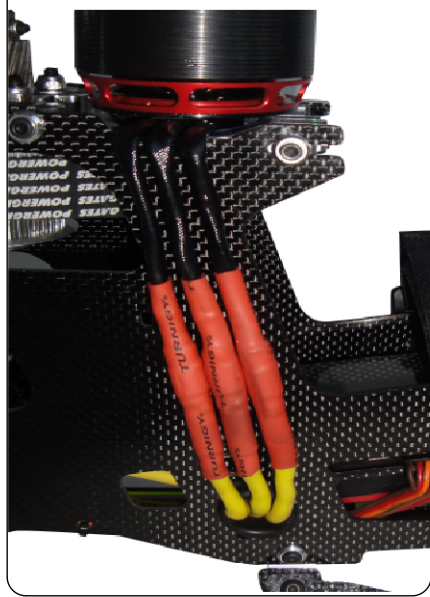



7-Boom and Tail

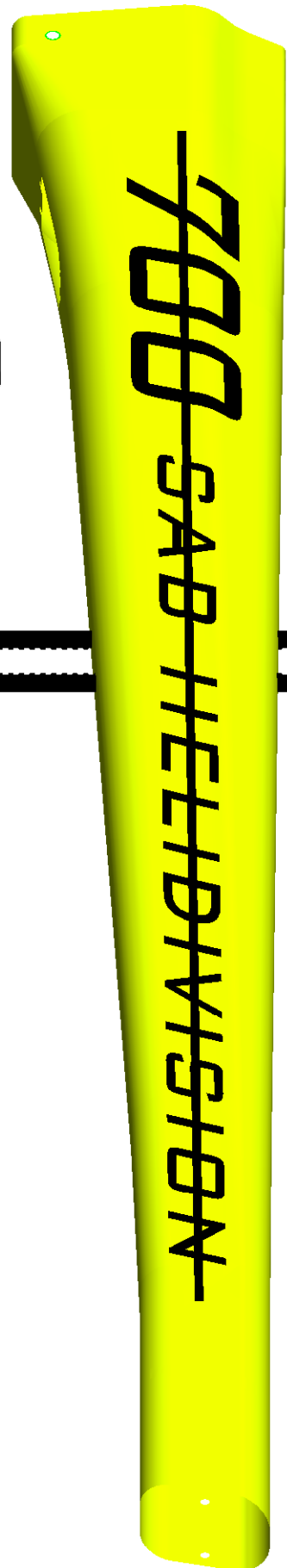
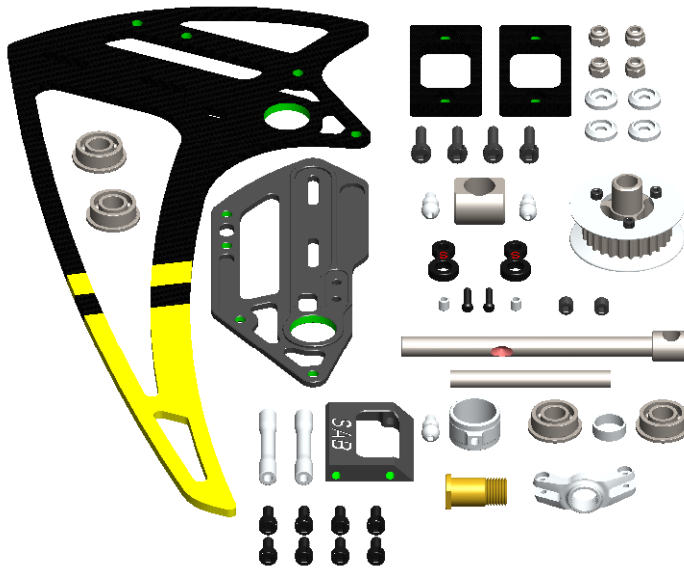
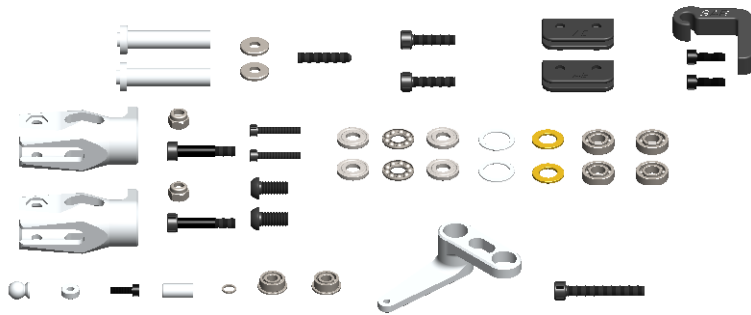



Bag 10, Tray 2

Tail Rotor Hub Assembly

Already Assembled

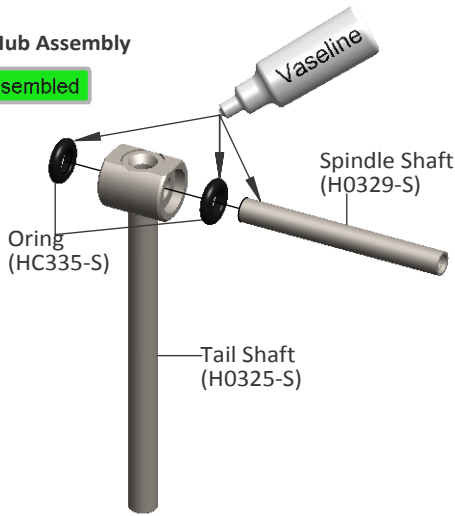

Tail Pitch Slider Assembly

Already Assembled

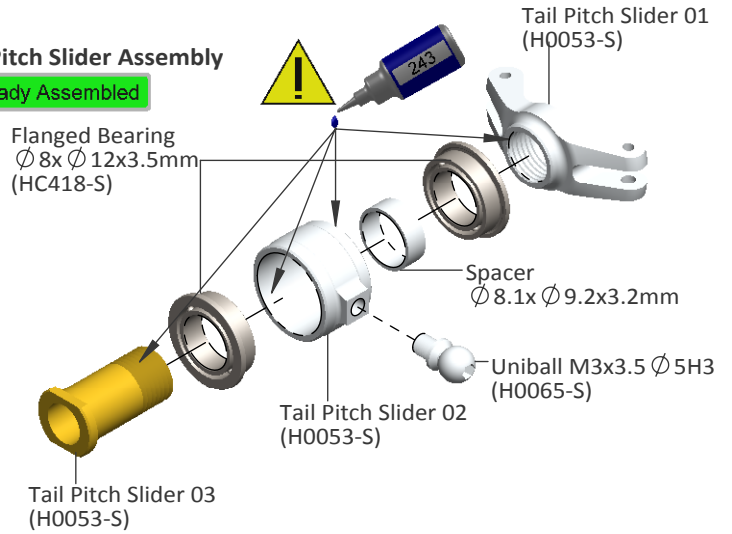

Bottom Head Cap Screw M4x6mm (HC096-S)

Thrust Bearing $\phi 5x \phi 10x4mm$ (HC435-S)

Tail Blade Grip (H0327-S)

Bearing $\phi 5x \phi 10x4mm$ (HC411-S)

Spacer $\phi 5x \phi 9x0.75mm$ (H0330-S)

Tail Rotor Hub Assembly

Spacer $\phi 5x \phi 9x0.75mm$ (H0330-S)

Tail Blade Grip Assembly

Note:
It is a normal for the tail to feel a bit tight after initial assembly as the tail spindle preload is usually high when the helicopter is brand new. The preload will loosen up after 2-5 flights allowing the system to become smooth.

Note: Smaller ID

Note: Larger ID

Bearing $\phi 5x \phi 10x4mm$ (HC411-S)

Spacer $\phi 7.5x \phi 10x0.5mm$ (H0349-S)

Socket Head Cap Screw M2x6mm (HC004-S)

Uniball M2.5x $\phi 5H6$ (H0064-S)

Tail Pitch Slider Link Assembly

Already Assembled

Tail Pitch Slider Assembly

Note: S >> Left Side

Socket Head Cap Screw M2x6mm (HC004-S)

Tail Pitch Slider Link (H0261-S)

Spacer $\phi 2x \phi 3x3mm$ (H0076-S)

Note: S >> Right Side

Bottom Head Cap Screw M4x6mm



...x2

Socket Head Cap Screw M2x6mm



...x4

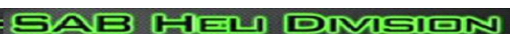



Bell Crank Lever Assembly

Bag 11, Tray 2

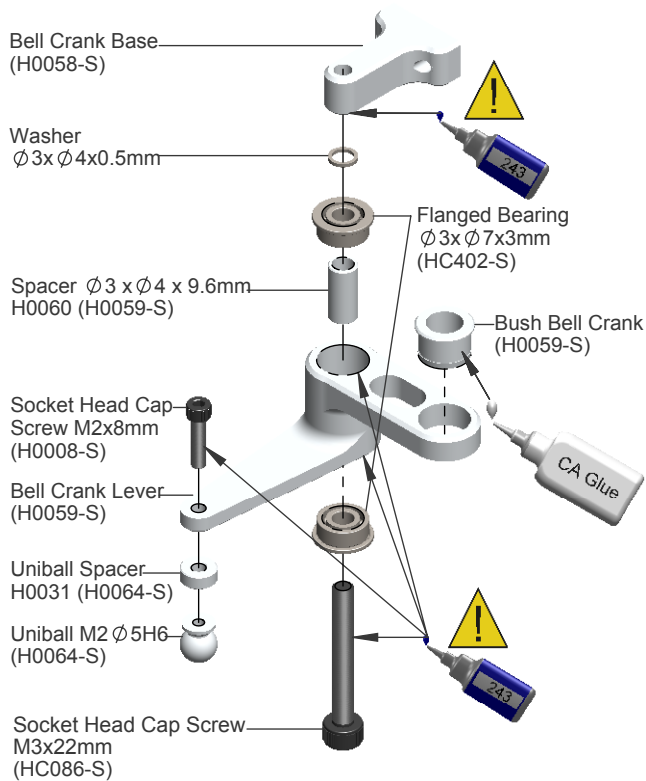

Tail Side Plate Assembly

Bag 12, Tray 2

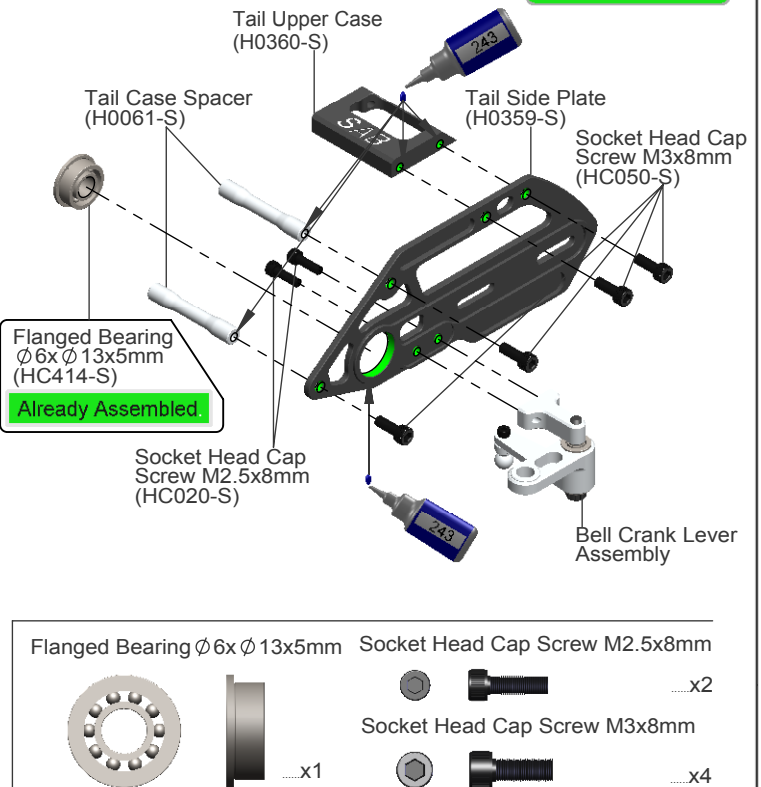

Tail System Assembly

Box 6, Bag 12, Tray 3

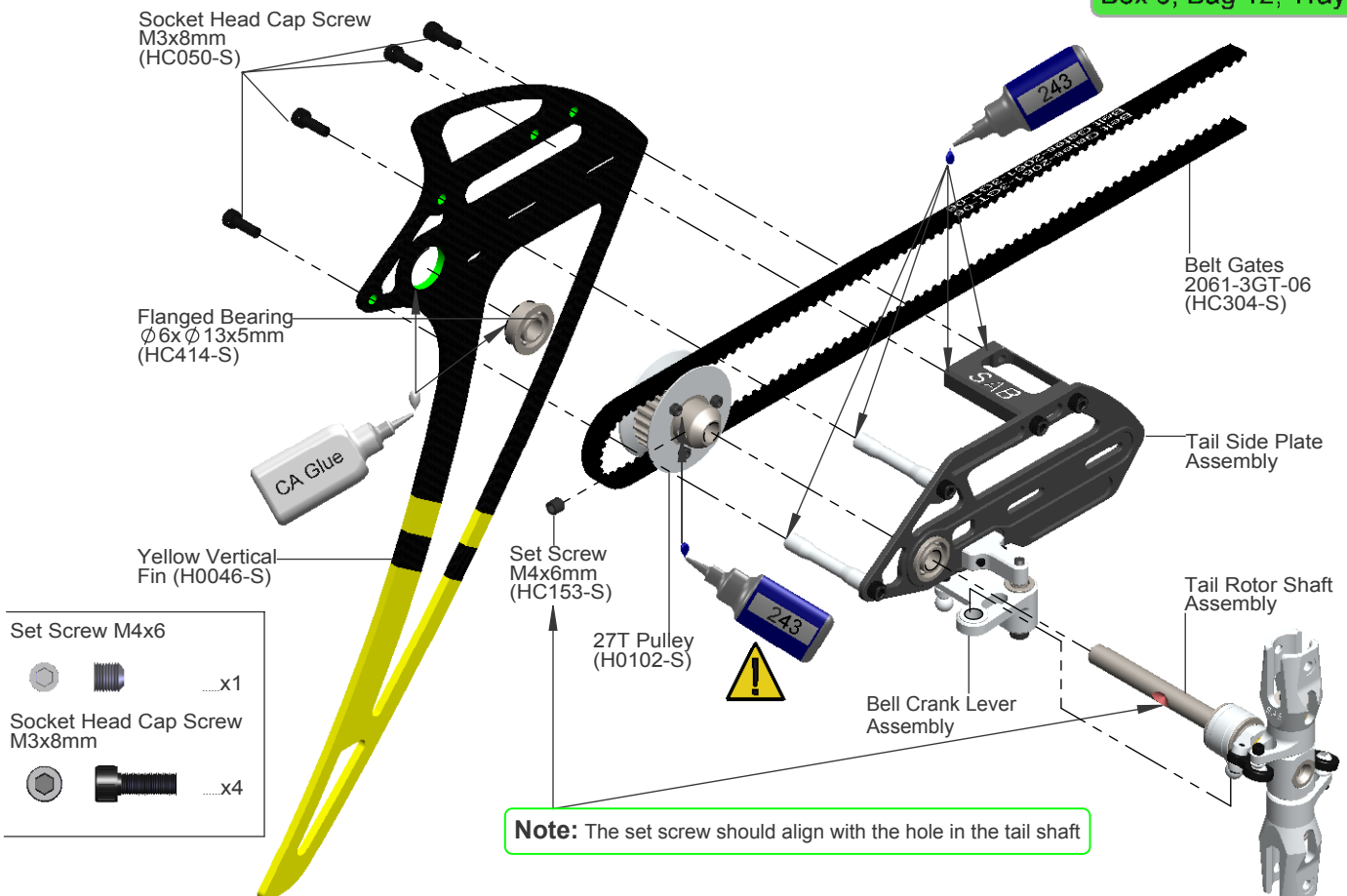



Tail Boom Assembly

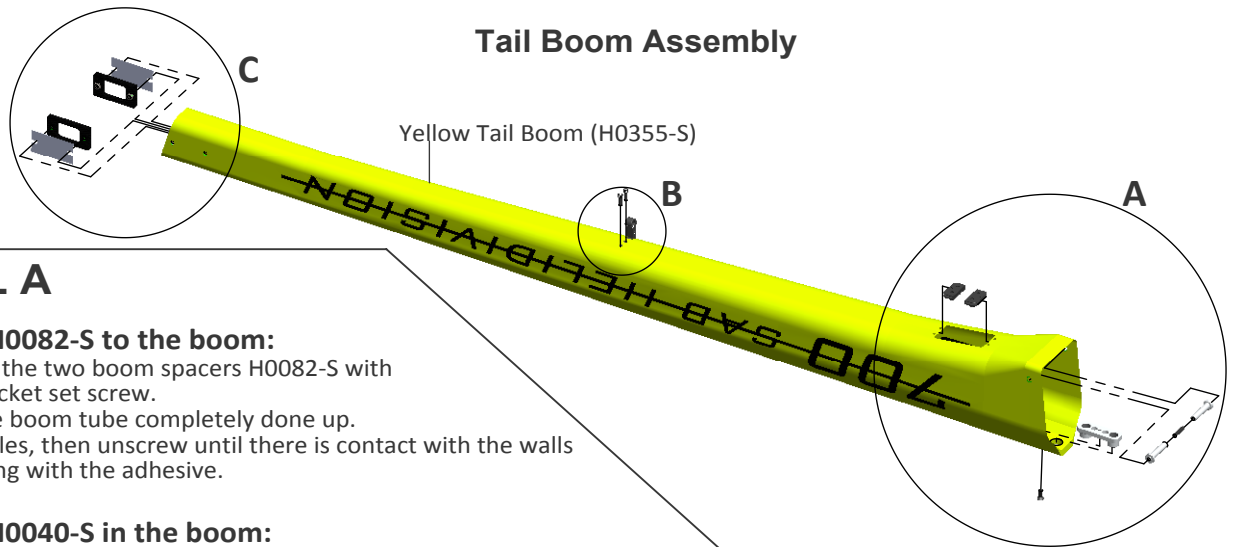

DETAIL A

Attaching H0082-S to the boom:

Pre-assemble the two boom spacers H0082-S with the M3x20 socket set screw. Insert into the boom tube completely done up. Center the holes, then unscrew until there is contact with the walls. Lock everything with the adhesive.

Assemble H0040-S in the boom:

Before assembling the two parts in the boom we suggest tightening the M2.5 screws into the two plastic parts to pre-thread them. In this way when you will assemble the tail servo it will be easier to tighten the screws into the plastic parts. Check the tail servo can fit, if necessary carefully sand the hole.

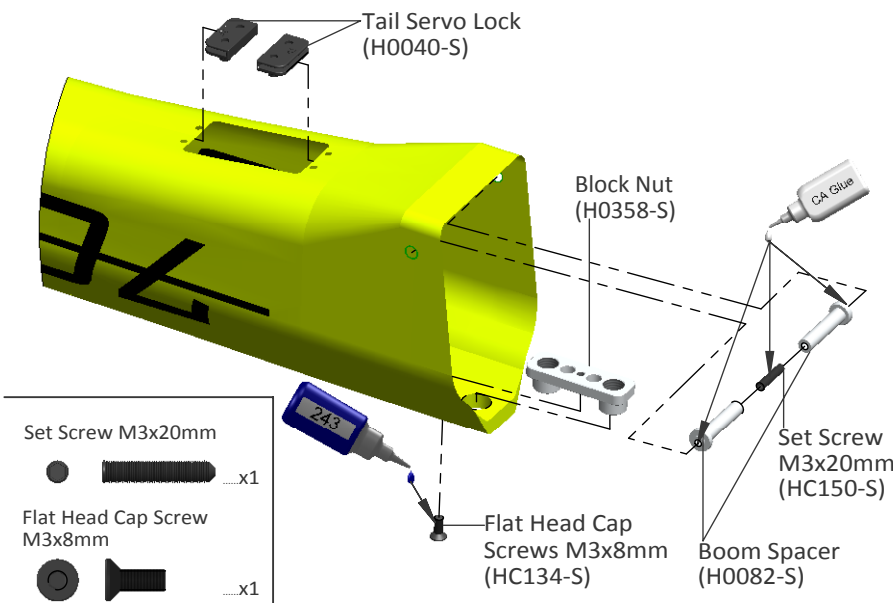

- Set Screw M3x20mm
.....x1
- Flat Head Cap Screw M3x8mm
.....x1

DETAIL B

Assemble H0045-S in the boom:

Before mounting H0045 on the boom we suggest to first tighten the M2.5 screws into the holes to thread them. In this way when you assemble the part it will be easier to tighten the screws.

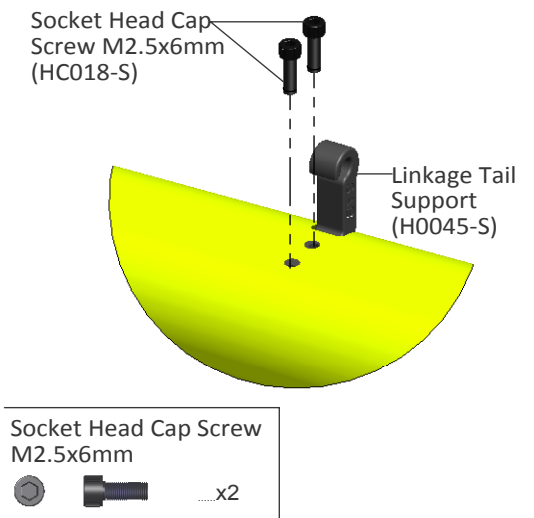

- Socket Head Cap Screw M2.5x6mm
.....x2

DETAIL C

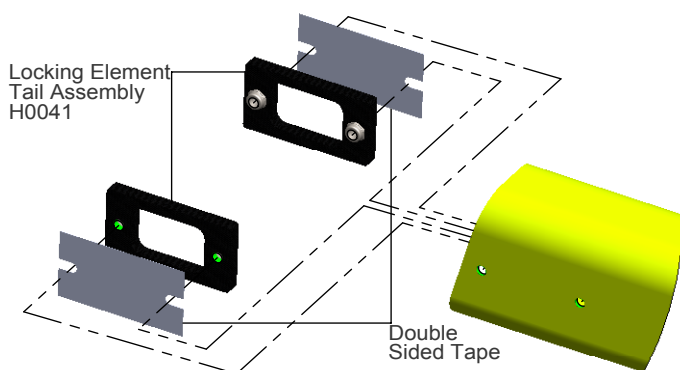

Locking Element Tail Assembly X 2

Already Assembled

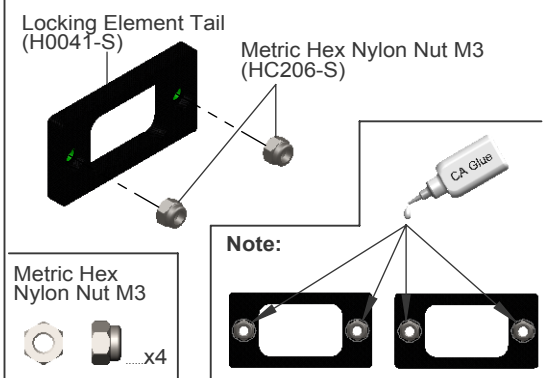

Note:

- Metric Hex Nylon Nut M3
.....x4



Bag 13

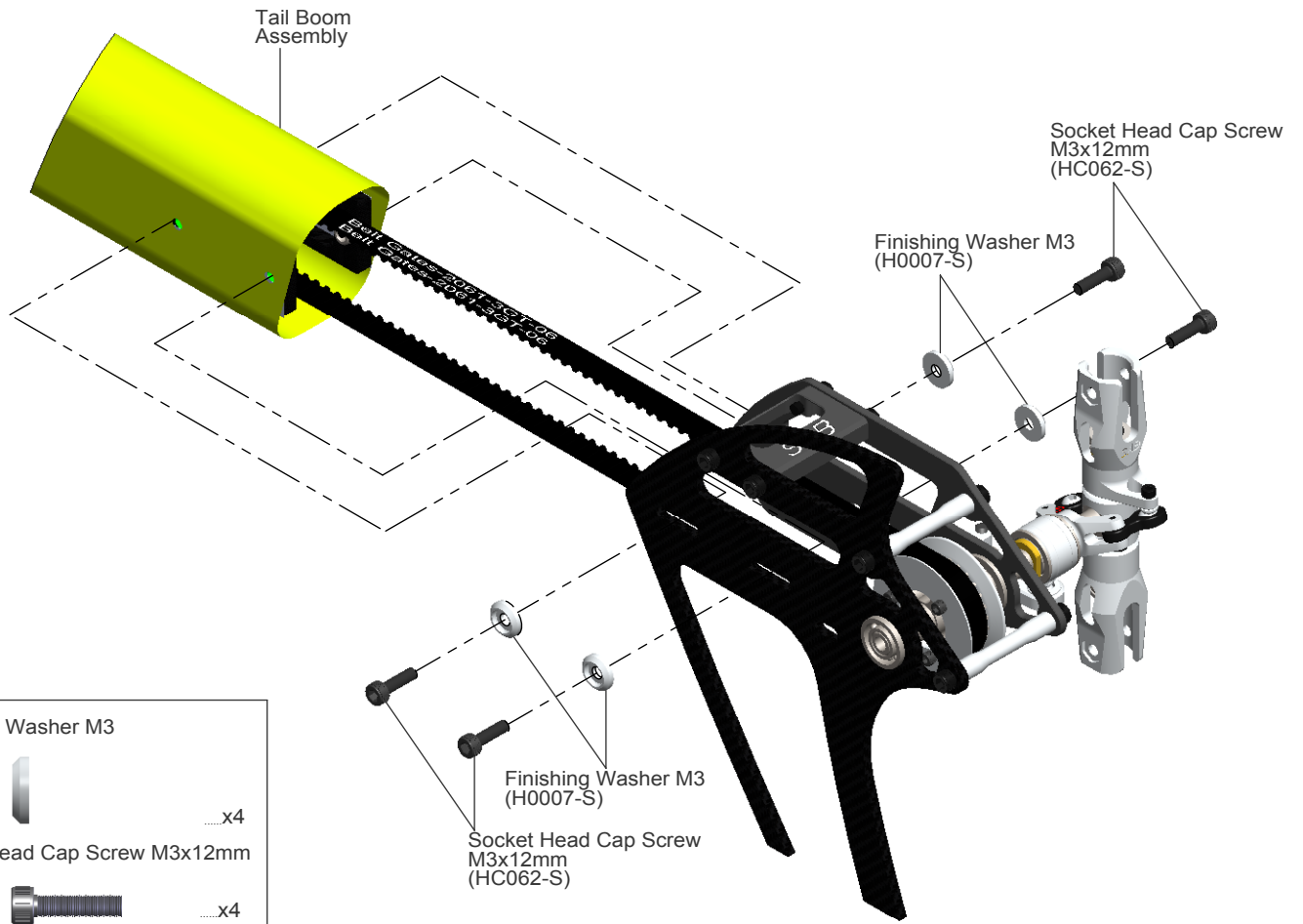

- Finishing Washer M3
-x4
- Socket Head Cap Screw M3x12mm
-x4

Box 3, Bag 16

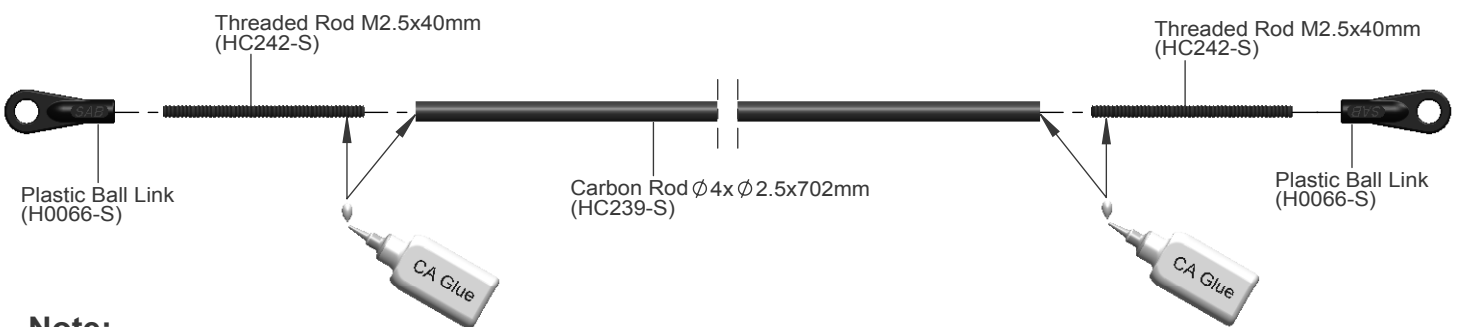

Note:

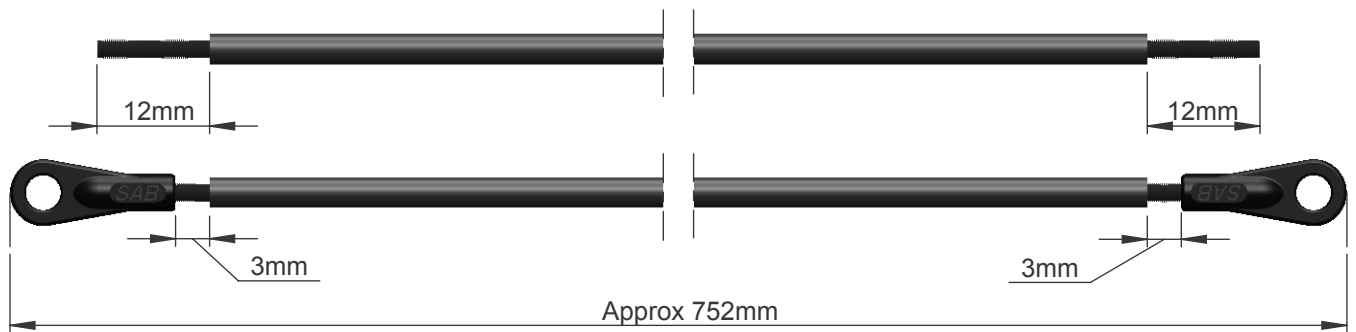

The distance between the axis and the ball must be between 15-16 mm

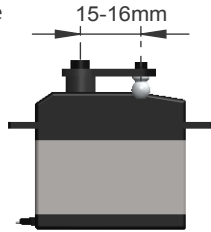

Tail Servo Assembly

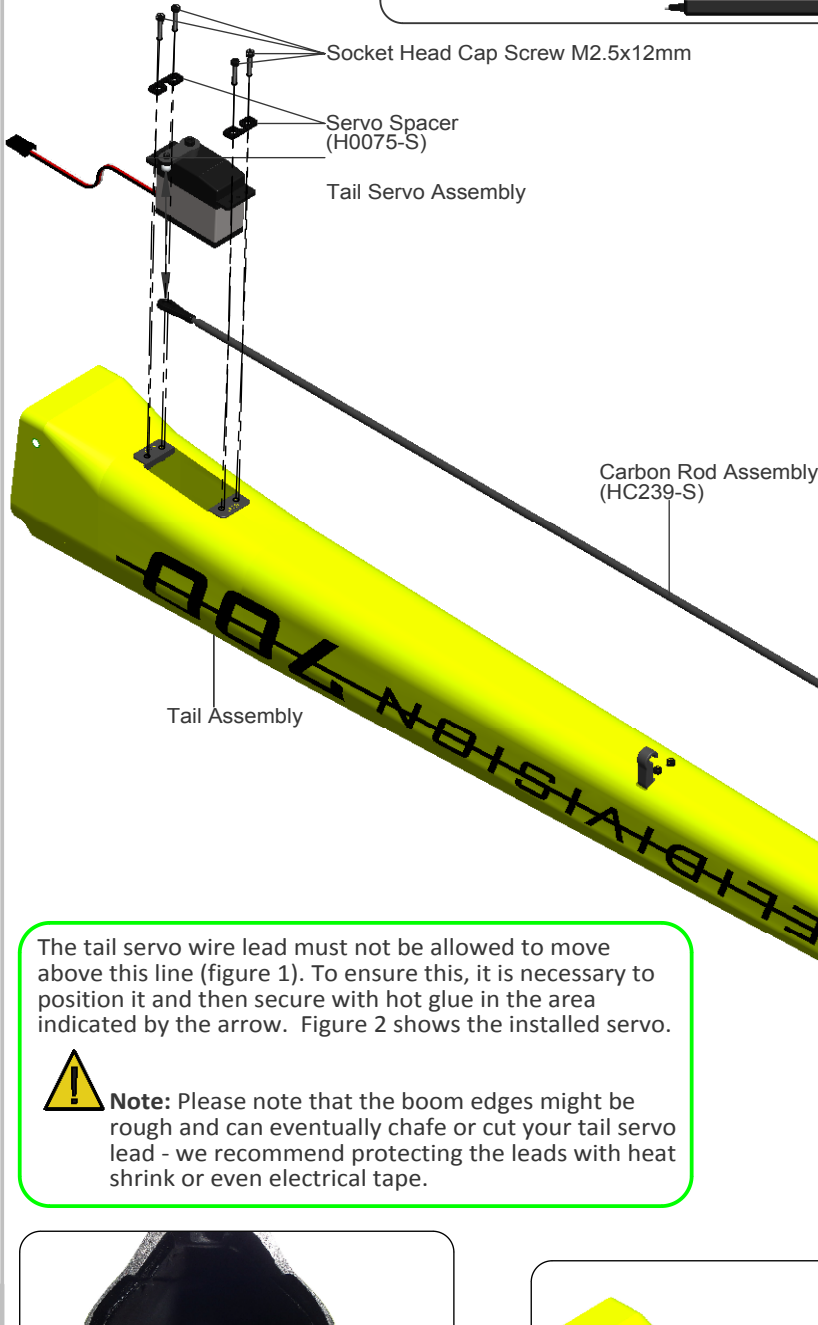
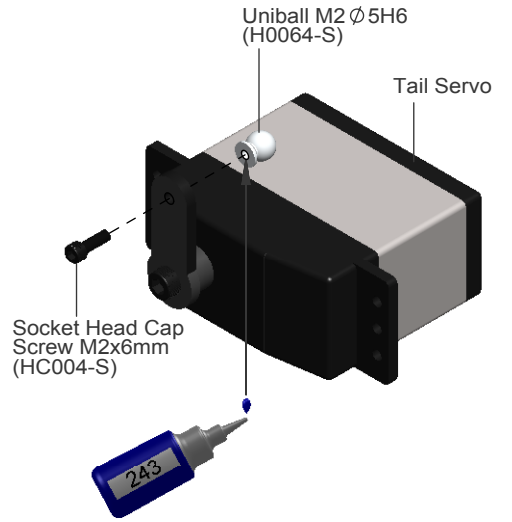

- Uniball M2 Ø5H6x1
- Socket Head Cap Screw M2x6mmx1
- Socket Head Cap Screw M2.5x12mmx4

The tail servo wire lead must not be allowed to move above this line (figure 1). To ensure this, it is necessary to position it and then secure with hot glue in the area indicated by the arrow. Figure 2 shows the installed servo.



Note: Please note that the boom edges might be rough and can eventually chafe or cut your tail servo lead - we recommend protecting the leads with heat shrink or even electrical tape.

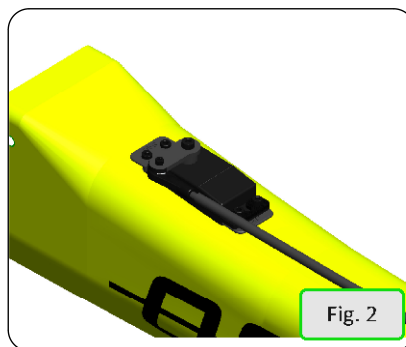
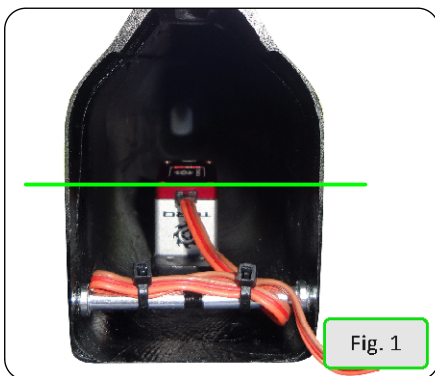



BOOM ASSEMBLY

- *Insert the tail boom assembly .
- *Lock the M8 nuts with the HA016 special tool supplied (Tray 2).
- *Firmly lock the lateral screws M3x12. Use Loctile for this screw and make sure you remain tight.
- *Assemble the H0038 carbon security plate .
- *Connect the tail servo wire to the previously fitted extension lead.

- Socket Head Cap Screw M3x6mm
 x1
- Finishing Washer M3
 x1
- Socket Head Cap Screw M3x12mm
 x2
- Nylon Screws M8x20mm
 x2

Fig. 2

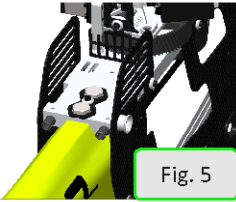
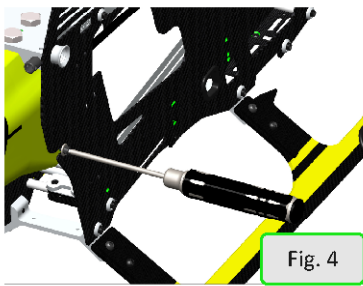
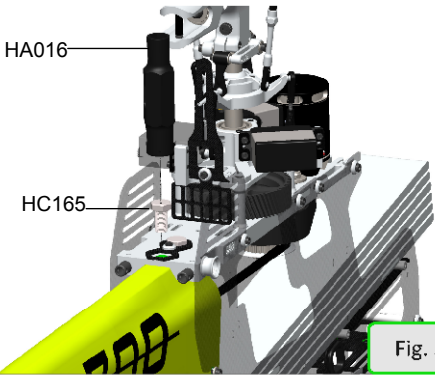
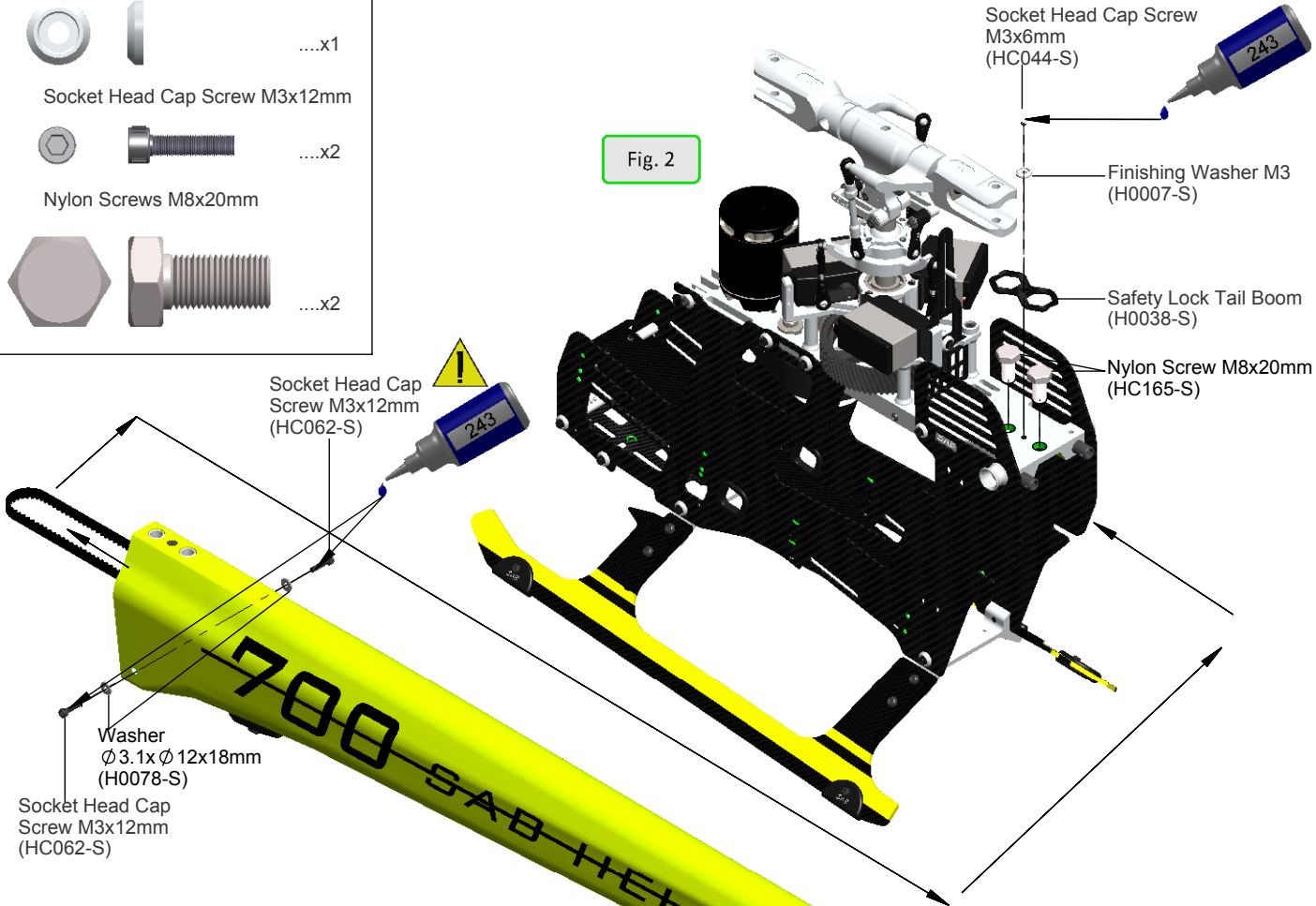



TAIL BELT TENSION

- *Check the proper assembly of the tail boom.
- *Check that the aluminum part of the tube is against the M3 stop screw.
- *Loosen the tail group by loosening the 4 M3 screws.
- *Install the belt onto the pulley, taking care to respect the direction of rotation (**figure 1**).
- *Rotate the tail drive several times by hand.
- *Load the spring by a rotation of **270°** the tensioning arm (**clockwise**)
- *Tension the boom until the tensioning arm is aligned with the frame.
- *Tighten the 4 screws.
- *Check that the tail output shaft is perpendicular to the tube. (**figure 2**)
- *In **figure 3,4,5** you can see the three conditions, ok, too loose and too tight.

NOTE. To disassemble the tail boom it is possible to remove the pulley H0101-S without loosening the tail unit. Remove the locking screw and pull down.

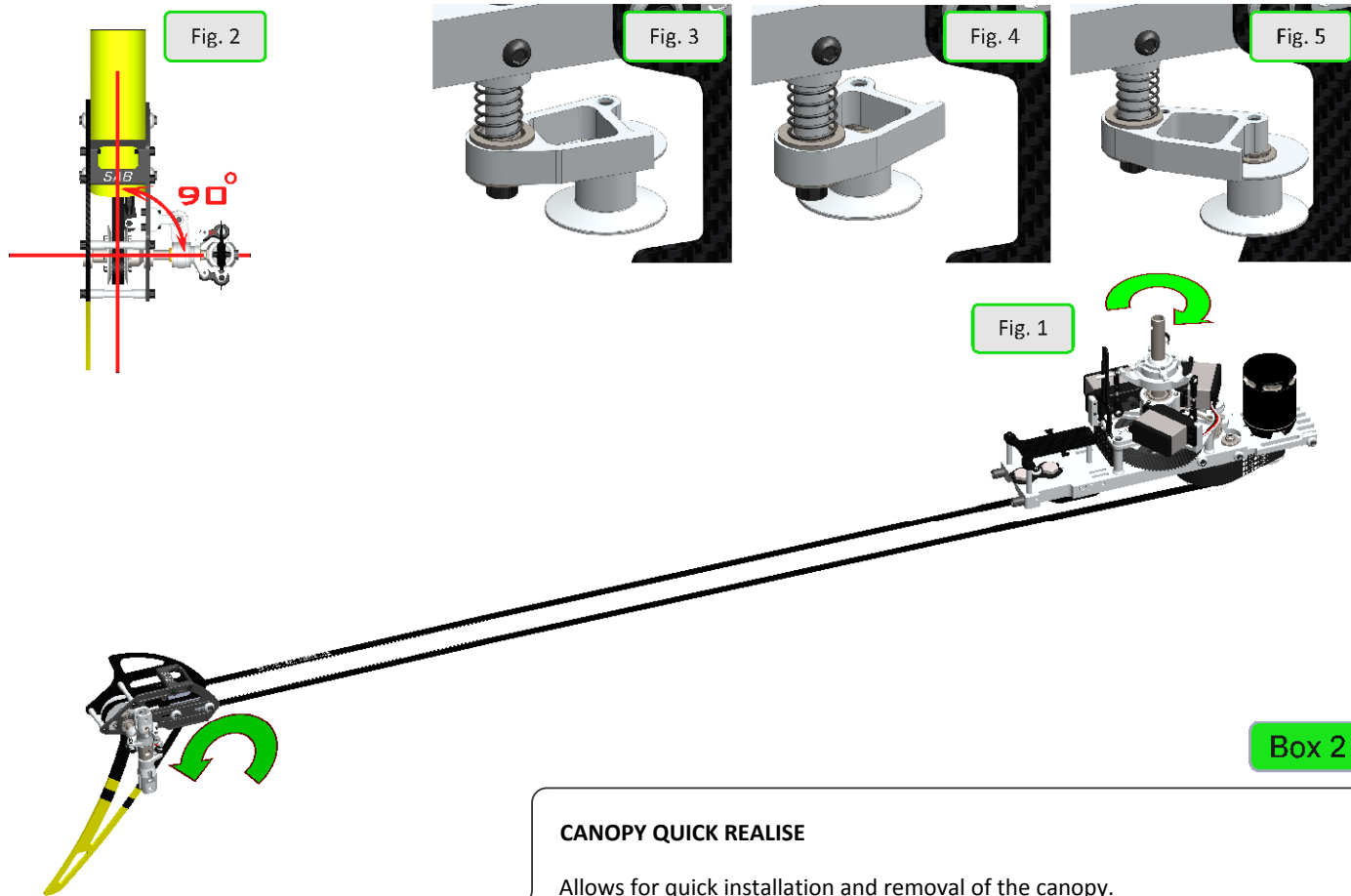

Box 2

CANOPY

On the Goblin, the canopy touches the frame. To avoid triggering vibration, it is necessary to attach an adhesive foam tape to the canopy (**figure 6**). To lock the canopy saver, normal is possible to use a little bit of CA Glue

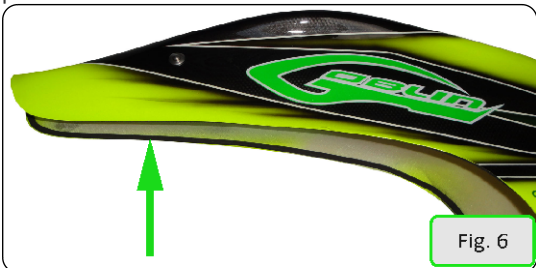

CANOPY QUICK REALISE

Allows for quick installation and removal of the canopy. The canopy hole must be 12 to 12.5 mm in diameter. You can enlarge the hole slightly to optimize the vertical position of the canopy itself. Always ensure the proper installation and locking before each flight. The lock button must always come out to ensure locking. It is recommended to attempt removal by forcing the canopy slightly to ensure proper locking.

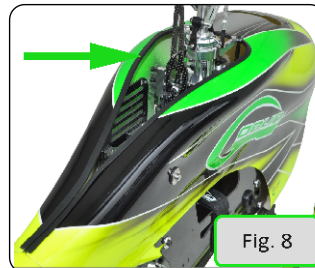

BATTERIES

The battery tray system in the Goblin 700 is simple, but very effective. The battery should be attached to the tray (Part **H0149**) with heat shrink, tape or velcro. You can optionally use the battery protection tray (Part **H0151**) see **Fig. 1, 2**. Before permanently mounting the batteries onto the battery tray, check the ideal position for the best center of gravity. Cut the heat shrink around the carbon fiber tray locking pins. **Fig. 3**.

Battery Pack:

Slide the tray until it locks into the CNC stopper. **Fig. 4, 5**. Using the velcro straps, making sure that the two locking pins are stopped against the frame spacer (Part1#**H0003** and #**H0151**) **Fig.6, 7**.

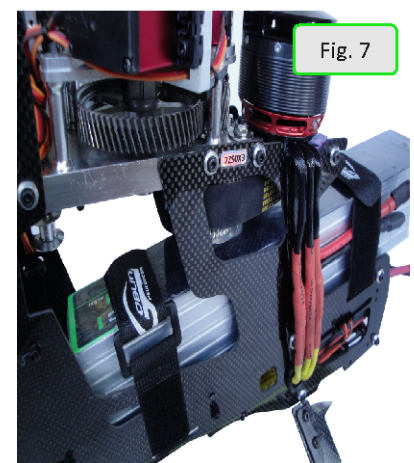
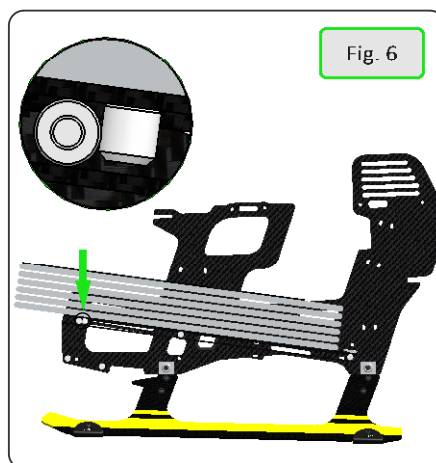
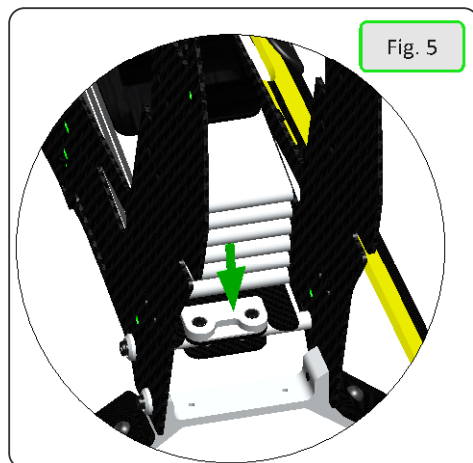
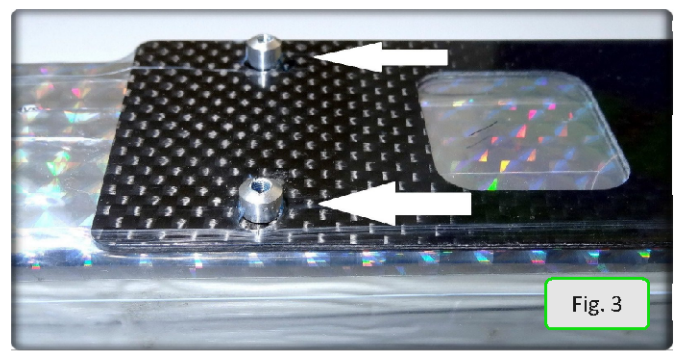
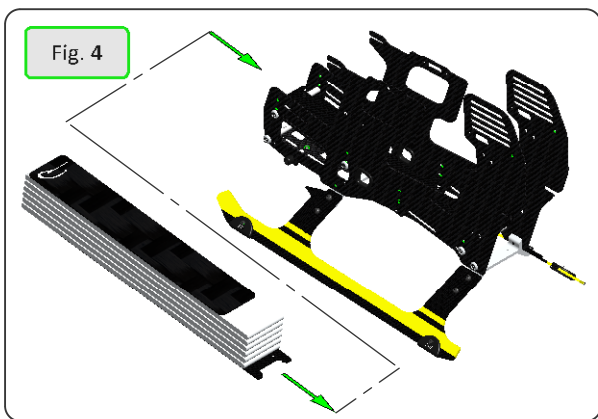
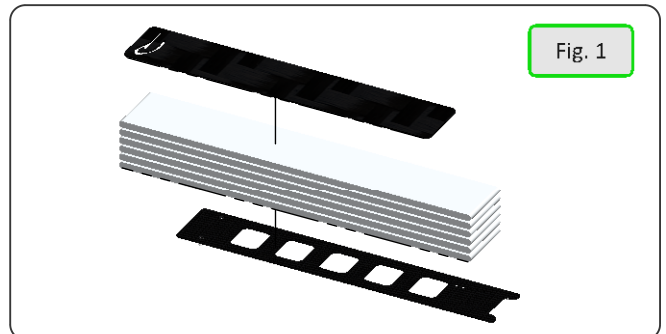
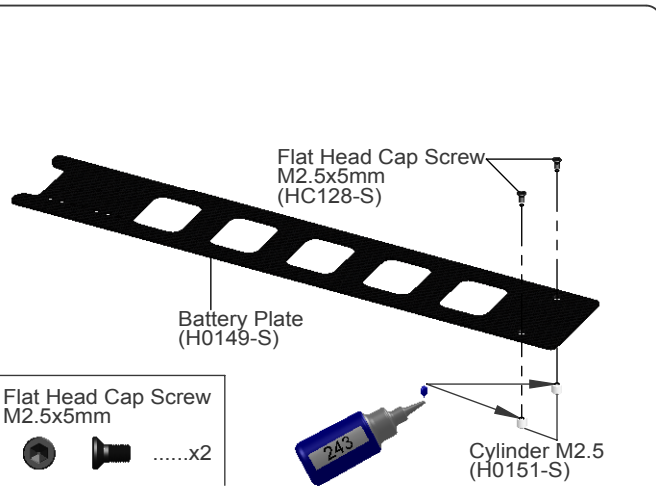



! SERIAL NUMBER

In Bag 21, i will find the serial number tag for your Helicopter

Sticking the tag as show. Please remember to register your product. (See page 1)



OPERATIONS BEFORE FLIGHT

- *Set up the remote control and the flybarless system with utmost care.
- *It is advisable to test the correct settings of the remote and flybarless system without main blades or tail blades fitted.
- *Check that all wiring is isolated from the carbon/aluminum parts. It is good practice to protect them at the points where they are at most risk.
- ! *Be sure of the gear ratio, verifying carefully the motor pulley in use. The forces acting on the mechanics increase enormously with increasing of rpm. Although the Goblin can fly at high rpm, for safety reasons we suggest to not exceed 2200 rpm.
- *Check the correct tension of the tail belt through the belt tensioner.
- *Fit the main blades and tail blades. (Fig.1 and Fig.2)
- *Please make sure the main blades are tight on the blade grips, you should be able to violently jerk the head in both directions and the blades should not fold. Failure to tighten the blades properly can result in a boom strike. To fold the blades for storage, it is advisable to loosen them.
- *Check the collective and cyclic pitch. For 3D flight, set about +/- 12°-13°.
- *It is important to check the correct tracking of the main blades.
- *On the Goblin, in order to correct the tracking, adjust the main link rod as shown in figure 3. This is provided with a right/left thread system that allows continuous fine adjustments of the length of the control rod; for this adjustment it is not necessary to detach the ball link.
- ! *Perform the first flight at a low headspeed, 1700/1800 RPM. After this first flight, do a general check of the helicopter. Verify that all screws are correctly tightened.

Bag 20

Fig. 1

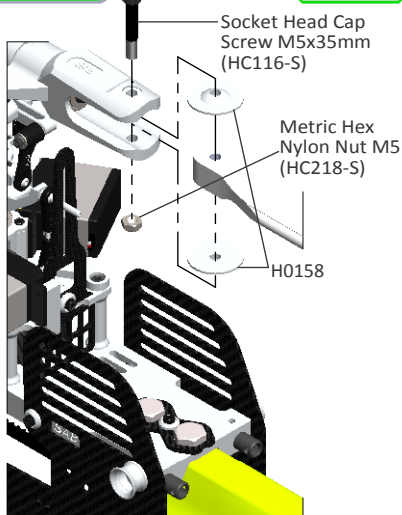

Bag 20

Fig. 2

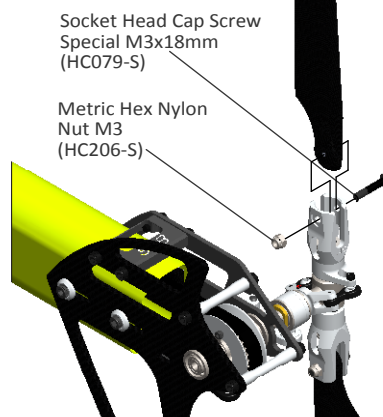
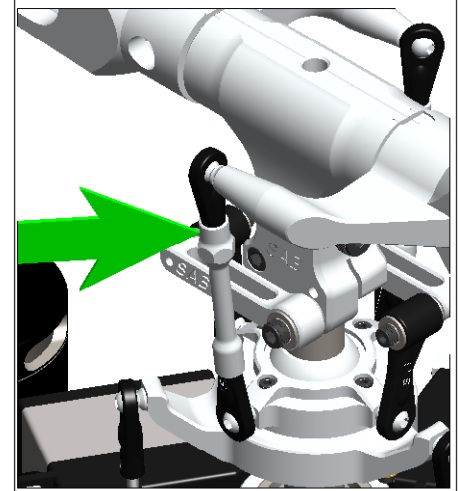

Fig. 3



IN FLIGHT

During its first flights the Goblin has to be "run in". The Damper, the main gear, the uniball and other parts must undergo some slight wear to operate smoothly. It is likely that during the very first flights the model may exhibit a swaying phenomena, particularly at low head speed. This phenomena disappears after a few flights.

If you want to fly in a generic way, using both low headspeed and high headspeed, the standard setting is the best compromise.

However, if you prefer flying at low speed [< 2000 rpm], for best results we recommend changing the tail pulley for a smaller one to increase tail rotor rpm. In this way, you will have extremely precise tail control even at low RPM. This pulley is available in the upgrade list [H0103-S]



HPS HEAD

- The dampening system of this head allows for a wide range of head speeds to be used without sacrificing safety.
- The dampers are composed of an o-ring and a technopolymer damper that defines the maximum possible movement of the spindle.
- The model response with change based on the preload, less preload (less shims) will allow for a softer feel and lower head speed, a high preload is used for hard 3D flight.
- To increase the preload, you can add an additional 0.2mm shim on each side, to decrease the preload, you can remove a 0.2mm shim on each side. It is important that the blade grips do not have the axial play so you must always keep the 1mm shim on each side regardless.

MAINTENANCE

*On the Goblin, areas to look for wear include:

- * Motor belt
- * Tail belt
- * Damper
- * Main gear and pinion

The lifespan of these components varies according to the type of flying. On average it is recommended to replace these special parts every **100** flights.

*The head tends to lose rigidity after a while. Check this condition every **20** flights. Preloading with precision shim washers, it is possible to vary the rigidity of the head.

*Check all uniballs often.

*The most stressed bearings are definitely those of the tail shaft. Check them frequently. All other parts are not particularly subject to wear.

*Periodically lubricate the tail slide movement and its linkages as well as the swashplate movement and its linkages.

*Lubricate the main gear with silicone and Tri-Flow Synthetic grease, even though the gear is made of technopolymer, a high mineral based filler, it still requires some lubrication.

*Check the screws that are highlighted in the following images frequently, make sure you remain tight (**fig.2** and **fig.3**).

*To ensure safety you should do a general inspection of the helicopter after each flight. You should check:

- * The maintenance of proper belt tension.
- * The proper isolation of wires from the carbon and aluminum parts.
- * That all screws remain tight.

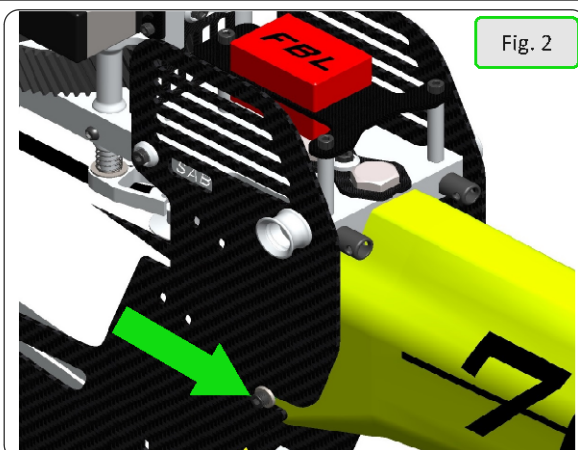

Fig. 2

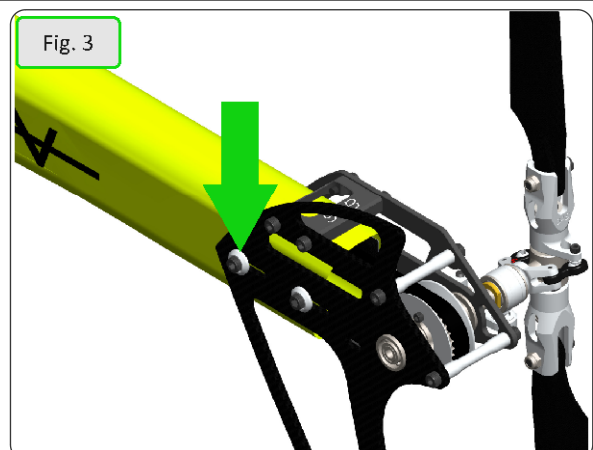
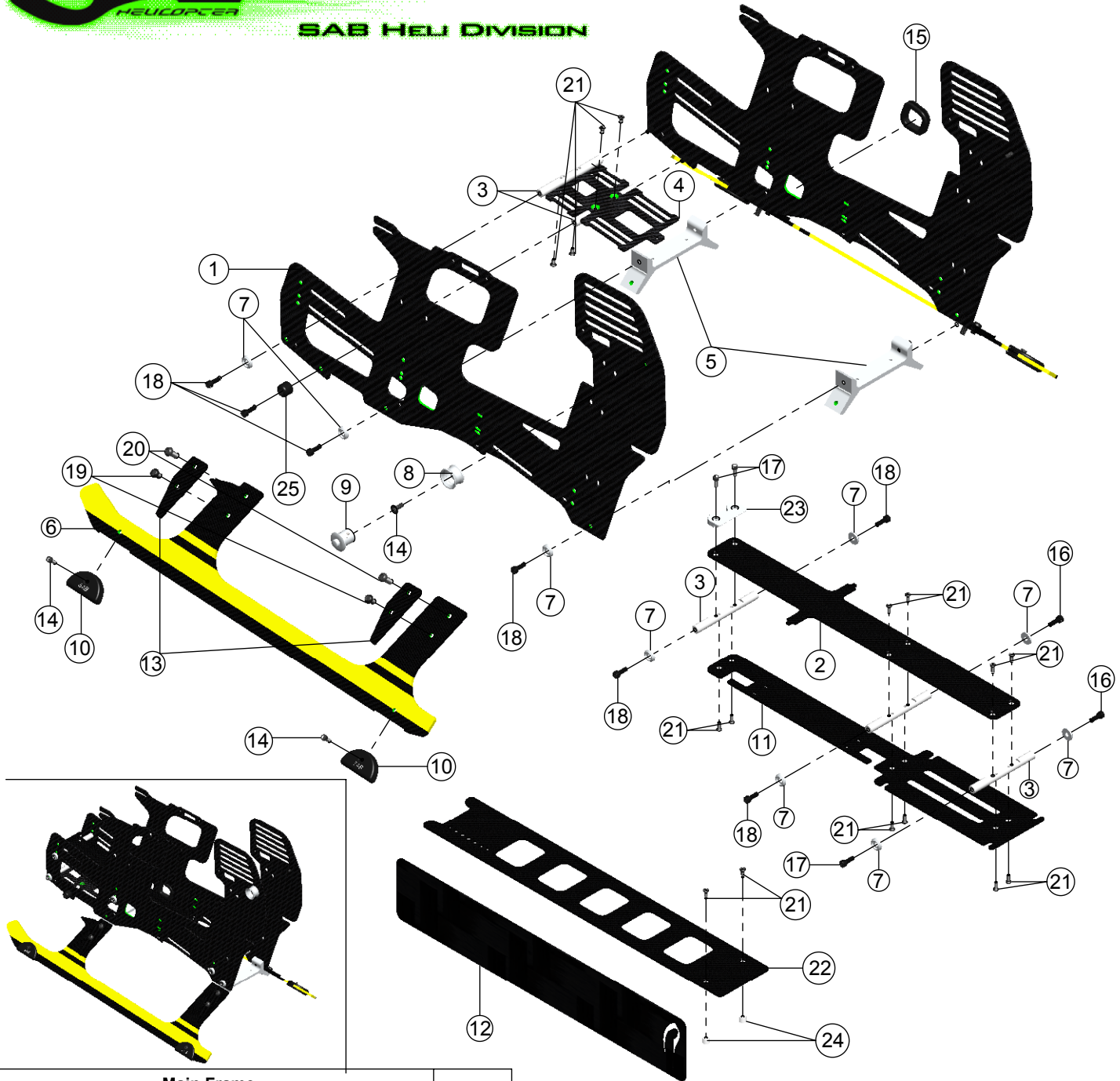
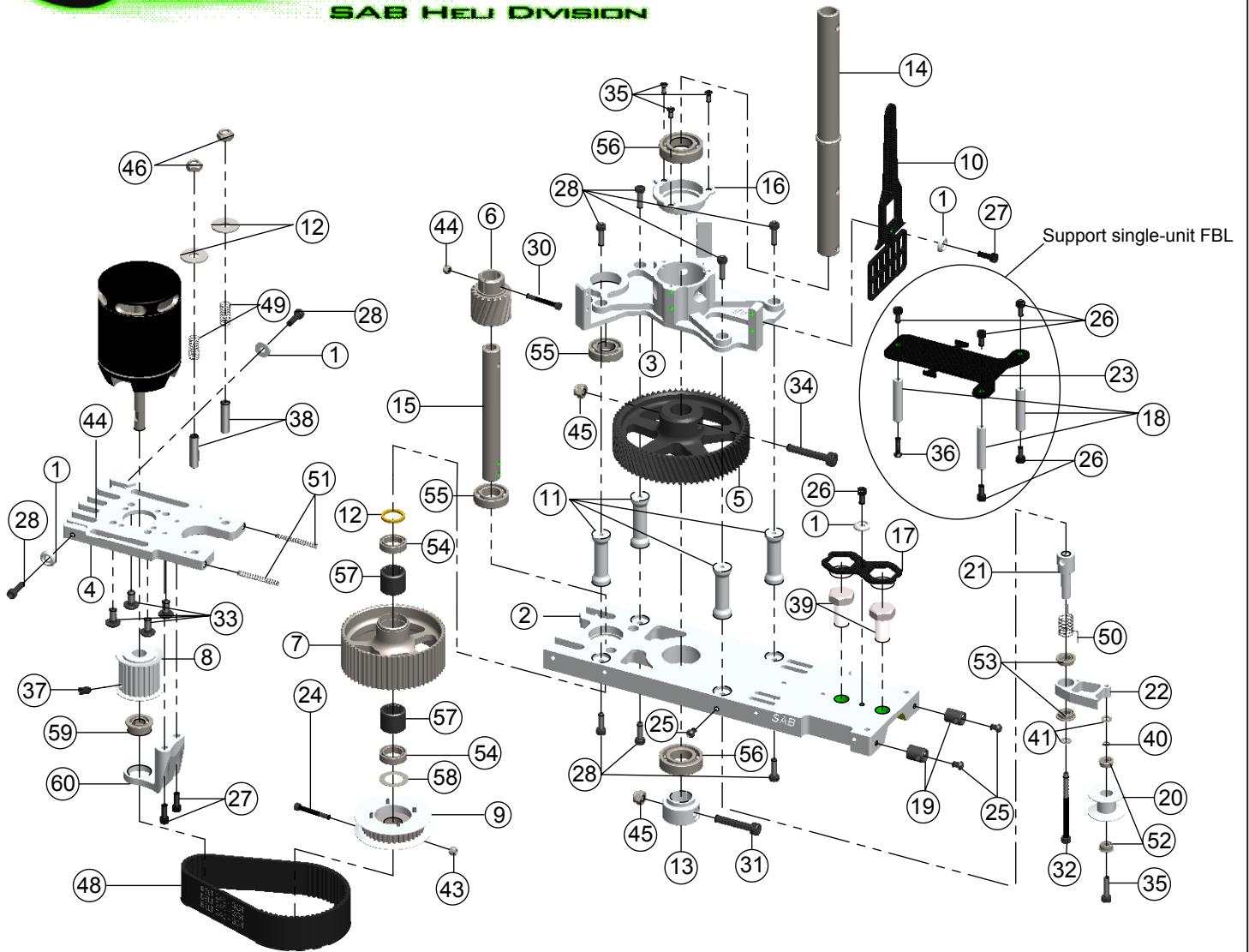

Fig. 3



Main Frame				
POS	COD	Name	Specification	Quantity
1	H0354	Main Frames	Carbon Fiber	2
2	H0002	Battery Tray	Carbon Fiber	1
3	H0003	Frame Spacers	Aluminum	5
4	H0088	ESC Support	Carbon Fiber	1
5	H0005	Landing Gear Supports	Aluminum	2
6	H0106	Yellow Landing Gears	Carbon Fiber	2
	H0162	Red Landing Gears	Carbon Fiber	2
7	H0007	Finishing Washers M3	Aluminum	12
8	H0319	Canopy Poitioner	Aluminum	2
		Canopy Quick Realise	Assembly	2
10	H0039	Landing Gear Protection	Plastic	4
11	H0153	Battery Support	Carbon Fiber	1
12	H0155	Battery Protection	Carbon Fiber	1

Main Frame				
POS	COD	Name	Specification	Quantity
13	H0074	Landing Gear Struts	Carbon Fiber	4
14	HC134	Flat Head Cap Screws	M3x8mm	2
15	HA010	Cable Pass	∅ 16 x ∅ 24 x 2mm	1
16	HC018	Socket Head Cap Screws	M2.5 x 6mm	4
17	HC020	Socket Head Cap Screws	M2.5 x 8mm	2
18	HC056	Socket Head Cap Screws	M3 x 10mm	16
19	HC096	Button Head Cap Screws	M4 x 6mm	4
20	HC100	Button Head Cap Screws	M4 x 10mm	4
21	HC128	Flat Head Cap Screws	M2.5 x 5mm	19
22	H0149	Battery Plate	Carbon Fiber	1
23	H0150	Stop Battery Plate	Aluminum	1
24	H0151	Cylinder M2.5	Aluminum	2
25	H0157	Canopy Positioners	Plastics	2



TRANSMISSION ASSEMBLY				
POS	COD	Name	Specification	Quantity
1	H0007	Finishing Washers M3	Aluminum	4
2	H0009	Main Structure	Aluminum	1
3	H0010	Servo Support	Aluminum	1
4	H0143	Motor Support	Aluminum	1
5	H0012	Main Gear	68T M1	1
6	H0156	Drive Pinion	19T M1	1
7	H0171	One Way Double Bearing	60T	1
8	H0175-22	Motor Pulley 20mm	22T	1
9	H0172	Front Tail Pulley Low	37T	1
10	H0017	Swash plate Anti-Rotation Guide	Carbon Fiber	1
11	H0018	Columns	Aluminum	4
12	H0110	Bush-One Ways	∅10 x ∅13 x 1.4mm	2
13	H0121	M4 Locking Collar		1
14	H0122	Main Shaft		1
15	H0157	Secondary Shaft		1
16	H0024	Main Shaft Bearing Support		1
17	H0038	Safety Locking Tail Boom	Carbon Fiber	1
18	H0043	Spacers Flybarless		3
19	H0050	Antenna Guide	Plastic	2
20	H0069	Tail Belt Idler		1
21	H0174	Column Belt Tensioner		1
22	H0071	Belt Tensioner Arm		1
23	H0077	Flybarless Support	Carbon Fiber	1
24	HC033	Socket Head Cap Screw Shoulderreds	M2.5 x 19mm	1
25	HC038	Button Head Cap Screws	M3 x 4mm	3
26	HC044	Socket Head Cap Screws	M3 x 6mm	5
27	HC050	Socket Head Cap Screws	M3 x 8mm	4
28	HC056	Socket Head Cap Screws	M3 x 10mm	7
29	HC062	Socket Head Cap Screw	M3 x 12mm	1
30	HC079	Socket Head Cap Screws	M3 x 18mm	1

TRANSMISSION ASSEMBLY				
POS	COD	Name	Specification	Quantity
31	HC104	Socket Head Cap Screw	M4 x 22mm	1
32	HC091	Socket Head Cap Shouldered	M4 x 40mm	1
33	HC098	Button Head Cap Screws	M4 x 8mm	4
34	HC111	Socket Head Cap Screw	M4 x 24mm	1
35	HC128	Flat Head Cap Screws	M2.5 x 5mm	3
36	HC134	Flat Head Cap Screw	M3 x 8mm	1
37	HC153	Set Screws	M4 x 6mm	1
38	HC158	Set Screws	M5 x 20mm	2
39	HC165	Vite Nylon Esa	M8 x 20mm	2
40	HC176	Washer	∅3 x ∅4x0.5mm	1
41	HC180	Washers	∅3.2 x ∅6 x 0.5mm	2
42	HC188	Washers	∅5.3 x ∅15 x 1mm	2
43	HC200	Metric Hex Nylon Nuts	M2.5 H3.5mm	2
44	HC206	Metric Hex Nylon Nuts	M3 H4mm	2
45	HC212	Metric Hex Nylon Nuts	M4 H5mm	2
46	HC218	Metric Hex Nylon Nuts	M5 H4.8mm	2
48	HC309	Big Motor Belt	240-3MGT	1
32	HC091	Socket Head Cap Screw	M3 x 40mm	1
49	HC310	Springs	De 5.8-df0.3-LL9	2
50	HC312	Spring	De 8-df0.5-LL8	1
51	HC314	Springs	De 8-df0.5-LL12	2
52	HC402	Flanged Bearings	∅3 x ∅7 x 3mm	2
53	HC410	Flanged Bearings	∅5 x ∅9 x 3mm	2
54	HC420	Bearings	∅10 x ∅15 x 4mm	2
55	HC422	Bearings	∅10 x ∅19 x 5mm	2
56	HC426	Bearings	∅12 x ∅24 x 6mm	2
57	HC442	One Way Bearing	∅10 x ∅14 x 12mm	2
58	HC232	Washer	∅10 x ∅16 x 0.2mm	1
59	HC414	Flanged Bearings	∅6 x ∅13 x 5mm	1
60	H0142	Support Bearing	Aluminum	1

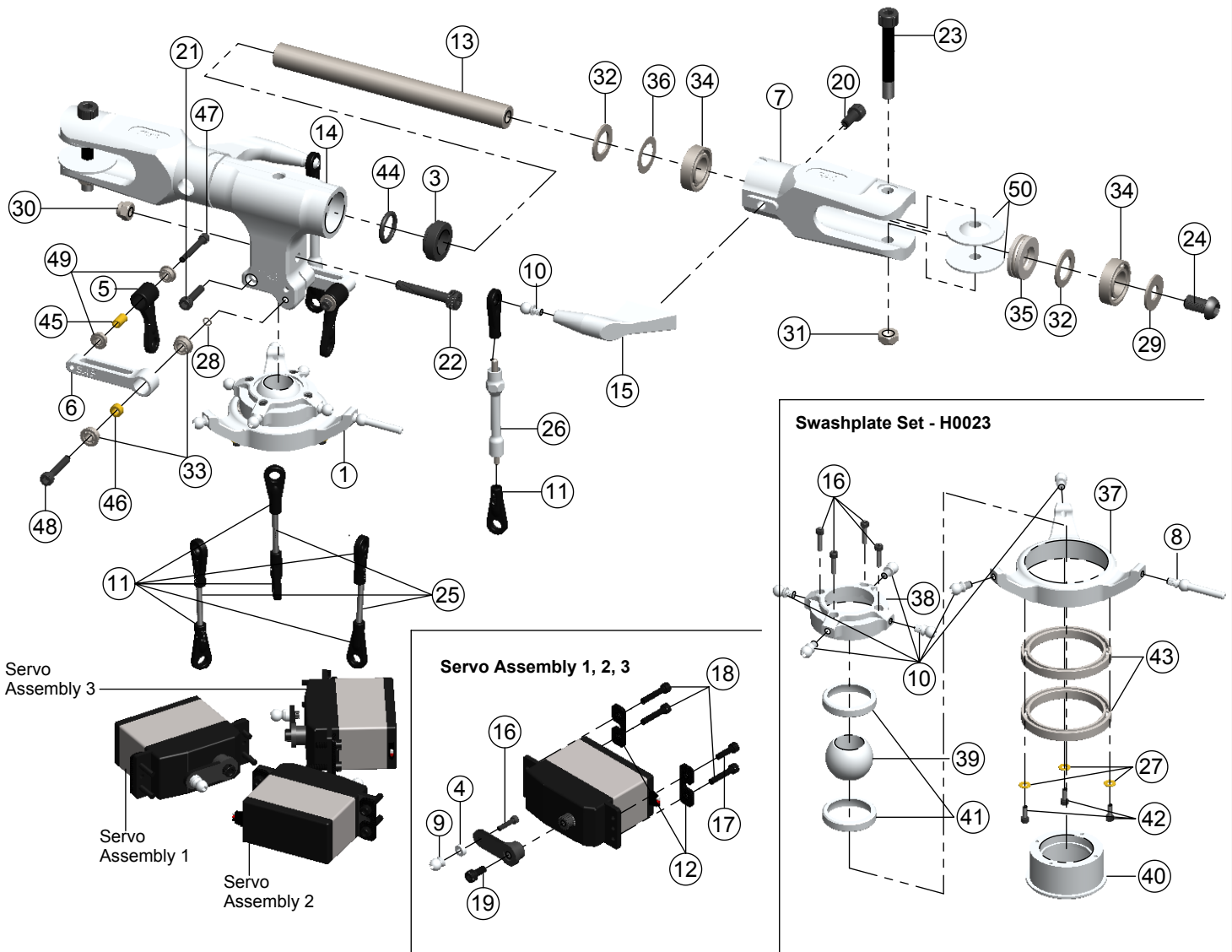

Head System				
POS	COD	Name	Specification	Quantity
1	H0023	Swashplate Set		1
3	H0144	Damper Derlin		2
4	H0031	Uniball Spacers	Aluminum	3
5	H0205	Unibal Radius Arms	Plastic	2
6	H0132	Radius Arms	Aluminum	2
7	H0182	Main Blade Grips	Aluminum	2
8	H0063	Uniball	M3 x 4 Ø5 H18	1
9	H0064	Uniballs	M2.5 Ø5 H6	3
10	H0065	Uniballs	M3 x 4 Ø5 H3	8
11	H0066	Plastic Ball Linkages	Plastic	8
12	H0075	Servo Spacers	Carbon Fiber	6
13	H0079	Spindle	Carbon Steel	1
14	H0135	Center Hub	Aluminum	1
15	H0183	Blade Grip Arms	Aluminum	2
16	HC008	Socket Head Cap Screws	M2 x 8mm	7
17	HC020	Socket Head Cap Screws	M2.5 x 8mm	3
18	HC026	Socket Head Cap Screws	M2.5 x 12mm	9
19	HC044	Socket Head Cap Screws	M3 x 6mm	3
20	HC102	Socket Head Cap Screws	M4 x 10mm	2
21	HC062	Socket Head Cap Screws	M3 x 12mm	2
22	HC111	Socket Head Cap Screw Shouldered	M4 x 24mm	1
23	HC116	Socket Head Cap Screw Shouldered	M5 x 35mm	2

Head System				
POS	COD	Name	Specification	Quantity
24	HC122	Button Head Cap Screws	M6 x 10mm	2
25	HC140	Threaded Rods	M2.5 x 18mm	3
26	H0346	Linkages Assembly		2
27	HC170	Washers	Ø2 x Ø5 x 0.5mm	3
28	HC176	Washers	Ø3 x Ø4 x 0.5mm	2
29	HC194	Washers	Ø6 x Ø14 x 1.5mm	2
30	HC212	Metric Hex Nylon Nut	M4 H5	1
31	HC218	Metric Hex Nylon Nuts	M5 H4.8	2
32	HC230	Washers	Ø10 x Ø16 x 1mm	4
33	HC402	Flanged Bearings	Ø3 x Ø7 x 3mm	4
34	HC422	Bearings	Ø10 x Ø19 x 5mm	4
35	HC438	Thrust Bearings	Ø10 x Ø18 x 5.5mm	2
36	HC232	Washers	Ø10 x Ø16 x 0.2mm	2
42	HC002	Socket Head Cap Screws	M2 x 5mm	3
43	HC430	Bearing Rads	Ø30 x Ø37 x 4mm	2
44	HA024	Oring	3050	2
45	H0235	Spacer Arm	Ø2.5 x Ø4 x 6.3mm	2
46	H0134	Spacer Arm	Ø3 x Ø5 x 2.7mm	2
47	HC032	Socket Head Cap Screws	M2.5 x 18mm	2
48	HC068	Socket Head Cap Screws	M3 x 16mm	2
49	HC400	Flanged Bearings	Ø2.5 x Ø6 x 2.5mm	4
50	H0158	Blade Washers	Ø5 x Ø24 x 1mm	4

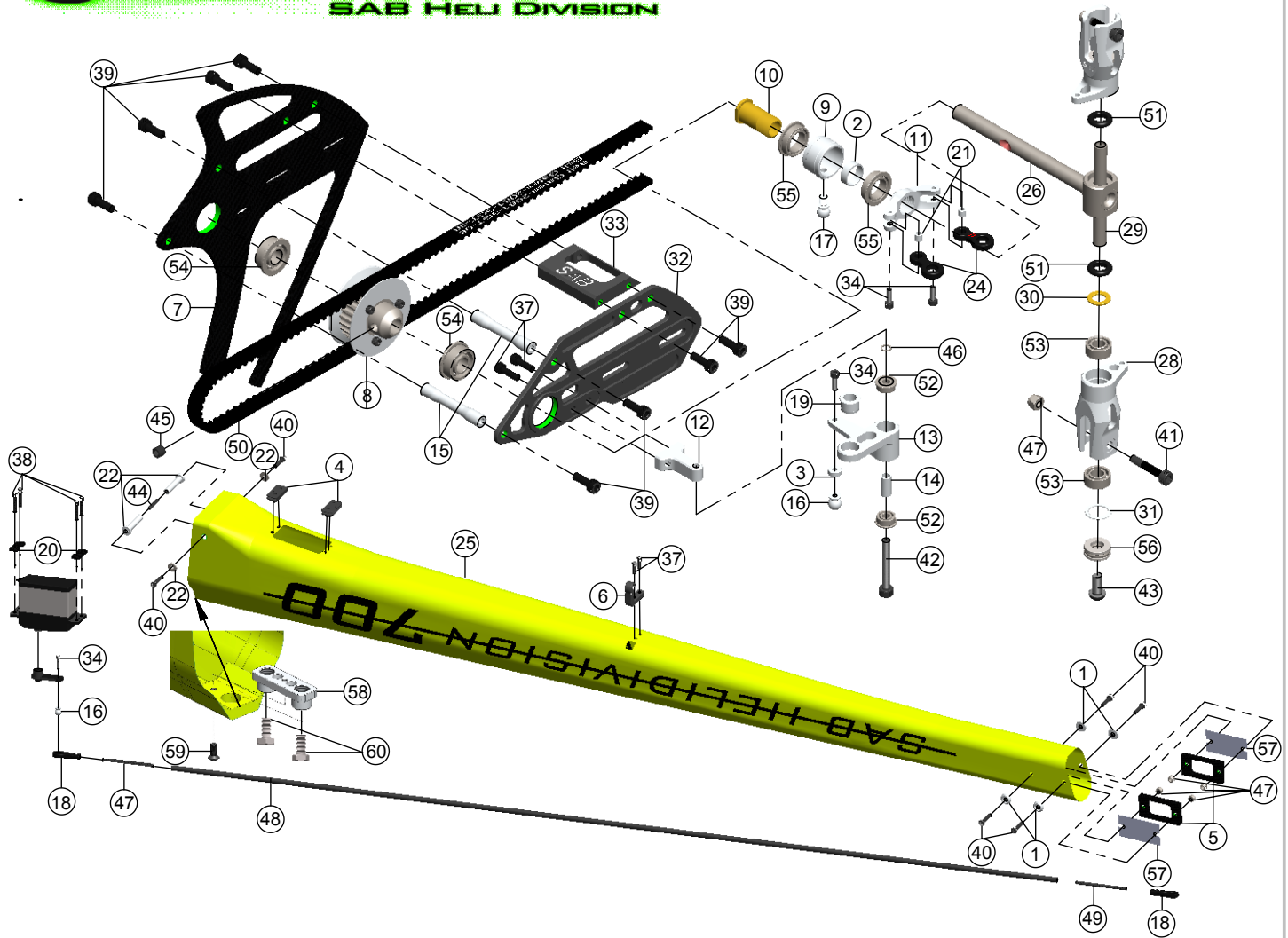

TAIL SYSTEM				
POS	COD	Name	Specification	Quantity
1	H0007	Finishing Washer M3	Aluminum	4
2	H0029	Spacer	Ø8.1 x Ø9.2 x 3.2mm	1
3	H0031	Uniball Spacer		1
4	H0040	Tail Servo Locks	Plastic	2
5	H0041	Locking Element Tails	Carbon Fiber	2
6	H0045	Linkage Tail Support	Plastic	1
7	H0046	Yellow Vertical Fin	Carbon fiber	1
	H0117	Red Vertical Fin	Carbon fiber	1
8	H0102	Tail pulley	27t	1
9	H0053	Tail pitch slider 01	Aluminum	1
10	H0054	Tail pitch slider 02	Aluminum	1
11	H0055	Tail pitch slider 03	Aluminum	1
12	H0058	Bell crank base	Aluminum	1
13	H0059	Bell crank lever	Aluminum	1
14	H0060	Spacer	Ø3 x Ø4 x 9.6mm	1
15	H0061	Tail case spacers	Aluminum	2
16	H0064	Uniballs	M2.5 Ø5H6	2
17	H0065	Uniballs	M3 x 4 Ø5H3	1
18	H0066	Plastic ball links	Plastic	2
19	H0072	Bush bell crank	Aluminum	1
20	H0075	Servo Spacer	Carbon Fiber	2
21	H0076	Grip link bushes	Aluminum	2
22	H0078	Washers	Ø3.1 x Ø12 x 1.8mm	2
23	H0082	Boom spacers		2
24	H0261	Tail pitch slider link	Plastic	2
25	H0355	Yellow Tail boom		1
26	H0325	Tail rotor shaft		1
27	H0326	Tail rotor hub		1
28	H0327	Tail blade grip		2
29	H0329	Tail Spindle		1
30	H0330	Washer	Spacer Ø5x Ø9x0.75mm	2

TAIL SYSTEM				
POS	COD	Name	Specification	Quantity
31	H0349	Washer	Spacer Ø7.5x Ø10x0.5mm	2
32	H0359	Tail Side Plate	Aluminum	1
33	H0360	Tail Upper Case	Aluminum	1
34	HC004	Socket Head Cap Screws	M2 x 6mm	3
35	HC008	Socket Head Cap Screws	M2 x 8mm	1
36	HC018	Socket Head Cap Screws	M2.5 x 6mm	6
37	HC020	Socket Head Cap Screws	M2.5 x 8mm	2
38	HC026	Socket Head Cap Screws	M2.5 x 12mm	4
39	HC050	Socket Head Cap Screws	M3 x 8mm	8
40	HC062	Socket Head Cap Screws	M3 x 12mm	6
41	HC079	Socket Head Cap Screws Shouldered	M3 x 18mm	2
42	HC086	Socket Head Cap Screws	M3 x 22mm	1
43	HC096	Button Head Cap Screws	M4 x 6mm	2
44	HC150	Set Screws	M3 x 20mm	3
45	HC153	Set Screws	M4 x 6mm	1
46	HC176	Washer		1
47	HC206	Metric Hex Nylon Nuts	M3	6
48	HC236	Carbon Rod	Ø2.5 x Ø4 x 702mm	1
49	HC242	Threaded Rods	M2.5 x 40mm	2
50	HC304	Belt Gates	2061-3GT-06	1
51	HC335	Oring	Rubber	2
52	HC402	Flanged Bearings	Ø3 x Ø7 x 3mm	2
53	HC411	Bearings	Ø5x Ø10x4mm	4
54	HC414	Flanged Bearings	Ø6 x Ø13 x 5mm	2
55	HC418	Flanged Bearings	Ø8 x Ø12 x 3.5mm	2
56	HC435	Thrust Bearings	Ø5x Ø10x4mm	2
57	HA015	Double-sided tapes		2
58	H0358	Block Nut		1
59	HC134	Flat Head Cap Screws M3x8mm		1
60	HC165	Nylon Screw M8x20mm		2







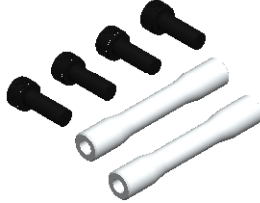
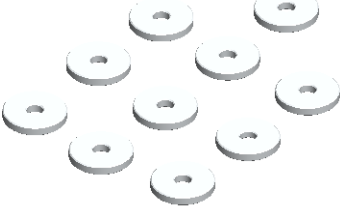

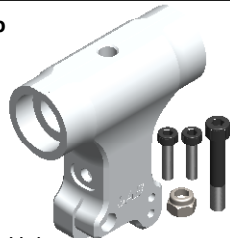

<p>Battery Tray [H0002-S]</p>  <p>- 1 x CF Battery Tray. - 6 x Flat Head Cap Screws M2.5x5mm.</p>	<p>Frame Spacer [H0003-S]</p>  <p>- 3 x Frame Spacers.</p>	<p>Landing Gear Support [H0005-S]</p>  <p>- 1 x Landing Gear Support.</p>	<p>Finishing Washer M3 [H0007-S]</p>  <p>- 10 x Finishing Washers M3.</p>
<p>Main Structure [H0009-S]</p>  <p>- 1 x Main Structure.</p>	<p>Servo Support [H0010-S]</p>  <p>- 1 x Servo Support.</p>	<p>68T Main Gear [H0012-S]</p>  <p>- 1 x 68T Main Gear . - 1 x Socket Head Cap Screw M4x25mm. - 1 x Metric Hex Nylon Nut M4 H5.</p>	<p>Swashplate Anti-Rotation Guide [H0017-S]</p>  <p>- 1 x CF Swashplate Anti-Rotation Guide. - 1 x Finishing Washer M3. - 1 x Socket Head Cap Screw M3x8mm.</p>
<p>Column [H0018-S]</p>  <p>4 x Columns.</p>	<p>Swashplate [H0023-S]</p>  <p>- 1 x Swashplate Assembly. - 2 x Bearings 30x Ø37x4mm. - 4 x Uniballs M3x4 Ø5 H3. - 1 x Uniball M3x4 Ø5 H18. - 3 x Socket Head Cap Screws M2x5mm. - 4 x Socket Head Cap Screws M2x8mm.</p>	<p>Bearing Support [H0024-S]</p>  <p>- 1 x Bearing Support. - 1 x Bearing Ø12x Ø24x6mm. - 3 x Flat Head Cap Screws M2.5x5mm.</p>	<p>Safety Lock Tail Boom [H0038-S]</p>  <p>- 1 x Safety Lock Tail Boom. - 1 x Finishing Washer M3. - 1 x Socket Head Cap Screw M3x8mm.</p>
<p>Sliding Landing Gear [H0039-S]</p>  <p>- 4 x Sliding Landing Gears. - 4 x Socket Head Cap Screws M2.5x6mm.</p>	<p>Tail Servo Lock [H0040-S]</p>  <p>- 2 x Tail Servo Locks. - 2 x Servo Spacers. - 4 x Socket Head Cap Screws M2.5x12mm.</p>	<p>Locking Element Tail [H0041-S]</p>  <p>- 2 x Locking Element Tails. - 4 x Metric Hex Nylon Nuts M3. - 2 x Double Sided Tapes.</p>	<p>Spacer Flybarless [H0043-S]</p>  <p>- 3 x Spacer Flybarless. - 1 x Supporto Flybarless. - 1 x Flat Head Cap Screw M3x8mm. - 5 x Socket Head Cap Screws M3x6mm.</p>
<p>Linkage Tail Support [H0045-S]</p>  <p>- 1 x Linkage Tail Support. - 2 x Socket Head Cap Screws M2.5x6mm.</p>	<p>Yellow Vertical Fin [H0046-S]</p>  <p>- 1 x Yellow Vertical Fin. - 2 x Socket Head Cap Screws M3x12mm. - 2 x Finishing Washers M3.</p>	<p>Antenna Guide [H0050-S]</p>  <p>- 2 x Antenna Guide. - 2 x Button Head Cap Screws M3x4mm.</p>	<p>Tail Pitch Slider [H0053-S]</p>  <p>- 1 x Tail Pitch Slider 01. - 1 x Tail Pitch Slider 02. - 1 x Tail Pitch Slider 03. - 1 x Spacer Ø8x Ø9x3.2mm. - 1 x Uniball M3x4 Ø5H3. - 2 x Flanged Bearings Ø8x Ø12x3.5mm</p>

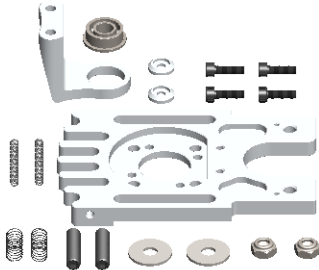

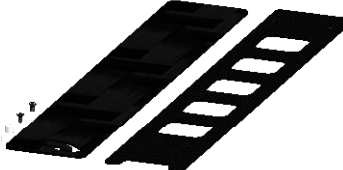
<p>Bell Crank Base [H0058-S]</p>  <p>- 1 x Bell Crank Base.</p>	<p>Bell Crank Lever [H0059-S]</p>  <p>- 1 x Bell Crank Lever. - 1 x Bush Bell Crank. - 1 x Washer $\varnothing 3 \times \varnothing 4 \times 0.5 \text{mm}$. - 1 x Spacer $\varnothing 3 \times \varnothing 4 \times 9.6 \text{mm}$. - 1 x Socket Head Cap Screw M3x22mm. - 2 x Flanged Bearings $\varnothing 3 \times \varnothing 7 \times 3 \text{mm}$.</p>	<p>Tail Case Spacer [H0061-S]</p>  <p>- 2 x Tail Case Spacers. - 4 x Socket Head Cap Screws M3x8mm.</p>	<p>Uniball M3x4 $\varnothing 5 \text{H}18$ [H0063-S]</p>  <p>- 1 x Uniball M3x4 $\varnothing 5 \text{H}18$</p>
<p>Uniball M2 $\varnothing 5 \text{H}6$ [H0064-S]</p>  <p>- 5 x Uniballs M2 $\varnothing 5 \text{H}6$. - 5 x Uniball Spacers. - 5 x Socket Head Cap Screws M2x8mm. - 5 x Socket Head Cap Screws M2x6mm.</p>	<p>Uniball M3x4 $\varnothing 5 \text{H}3$ [H0065-S]</p>  <p>- 5 x Uniballs M3x4 $\varnothing 5 \text{H}3.5$.</p>	<p>Plastic Ball Link [H0066-S]</p>  <p>10 x Plastic Ball Link</p>	<p>Landing Gear Struts [H0074-S]</p>  <p>- 4 x Landing Gear Struts. - 4 x Button Head Cap Screws M4x6mm. - 4 x Button Head Cap Screws M4x10mm.</p>
<p>Servo Spacer [H0075-S]</p>  <p>-10 x Servo Spacers.</p>	<p>Washer $\varnothing 3.1 \times \varnothing 12 \times 1.8 \text{mm}$ [H0078-S]</p>  <p>- 10 x Washers $\varnothing 3.1 \times \varnothing 12 \times 1.8 \text{mm}$.</p>	<p>Spindle [H0079-S]</p>  <p>- 1 x Spindle. - 2 x Button Head Cap Screw M6x10mm. - 2 x Washer $\varnothing 6 \times \varnothing 14 \times 1.5 \text{mm}$</p>	<p>Boom Spacer [H0082-S]</p>  <p>- 2 x Boom Spacer. - 1 x Set Screw M3x20mm</p>
<p>ESC Support [H0088-S]</p>  <p>- 1 x ESC Support. - 2 x Frame Spacer. - 4 x Flat Head Cap Screws M2.5x5mm.</p>	<p>27T Tail Pulley [H0102-S]</p>  <p>- 1 x 27T Tail Pulley. - 1 x Set Screw M4x4mm. - 6 x Socket Head Cap Screws M2x5mm.</p>	<p>Yellow Landing Gear [H0106-S]</p>  <p>- 1 x CF Yellow Landing Gear.</p>	<p>Bush One Way [H0110-S]</p>  <p>- 4 x Bush One Ways.</p>
<p>Red Vertical Fin [H0117-S]</p>  <p>- 1 x Red Vertical Fin. - 2 x Socket Head Cap Screws M3x12mm. - 2 x Finishing Washers M3.</p>	<p>M4 Locking Collar [H0121-S]</p>  <p>- 1 x M4 Locking Collar. - 1 x Socket Head Cap Screw M4x22mm. - 1 x Metric Hex Nylon Nut M4 H5.</p>	<p>Main Shaft [H0122-S]</p>  <p>- 1 x Main Shaft. - 1 x M4 Locking Collar - 1 x Socket Head Cap Screw Shouldered M4x24mm. - 2 x Socket Head Cap Screws M4x22mm. - 3 x Metric Hex Nylon Nuts M4 H5.</p>	<p>Radius Arm [H0132-S]</p>  <p>-2 x Radius Arms. -2 x Spacer Arm $\varnothing 3 \times \varnothing 5 \times 2.7 \text{mm}$. -2 x Spacer Arm $\varnothing 2.5 \times \varnothing 4 \times 6.3 \text{mm}$. -2 x Uniball Radius Arms. -2 x Socket Head Cap Screws M3x16mm. -2 x Socket Head Cap Screws M2.5x18mm. -2 x Washers $\varnothing 3 \times \varnothing 4 \times 0.5 \text{mm}$. -2 x Flanged Bearings $\varnothing 2.5 \times \varnothing 6 \times 2.5 \text{mm}$. -2 x Flanged Bearings $\varnothing 3 \times \varnothing 7 \times 3 \text{mm}$.</p>

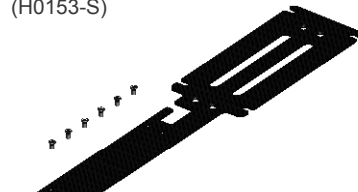
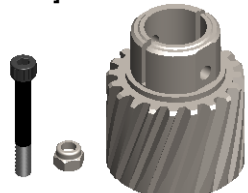

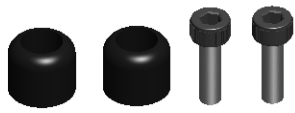
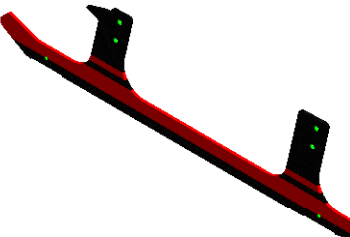
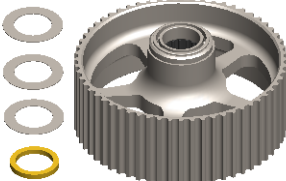
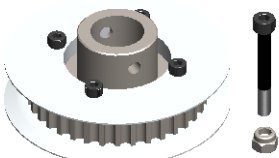
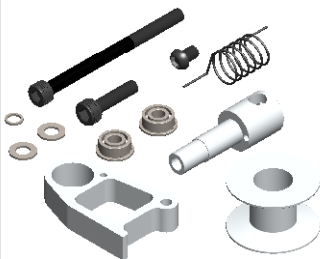
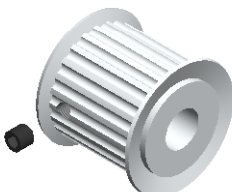
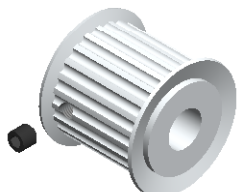

























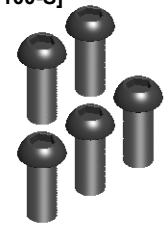

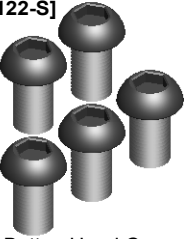

<p>Center Hub [H0135-S]</p>  <ul style="list-style-type: none"> - 1 x Center Hub. - 1 x Socket Head Cap Screw Shouldered M4x24mm. - 1 x Metric Hex Nylon Nut M4 H5.. - 2 x Socket Head Cap Screws M3x12mm. 	<p>Bearing Support [H0142-S]</p>  <ul style="list-style-type: none"> - 1 x Bearing 3° Support. - 1 x Flanged Bearing $\varnothing 6 \times \varnothing 13 \times 5 \text{mm}$. - 2 x Socket Head Cap Screws M3x8mm. 	<p>Motor Mount [H0143-S]</p>  <ul style="list-style-type: none"> - 1 x Bearing 3° Support. - 1 x Motor Support. - 1 x Flanged Bearing $\varnothing 6 \times \varnothing 13 \times 5 \text{mm}$. - 2 x Socket Head Cap Screws M3x8mm. - 2 x Set Screws M5x20mm. - 2 x Washers $\varnothing 5.3 \times \varnothing 15 \times 1 \text{mm}$. - 2 x Metric Hex Nylon Nuts M5H4.8. - 2 x Finishing Washers M3. - 2 x Socket Head Cap Screws M3x10mm. - 2 x Metric Hex Nylon Nut M3 H4. - 2 x Springs de 5.8/ df0.5 / LL9. - 2 x Springs de 3/ df0.5 / LL12. 	
<p>Damper [H0144-S]</p>  <ul style="list-style-type: none"> - 2 x Damper Derlin. - 2 x Washers $\varnothing 10 \times \varnothing 16 \times 1 \text{mm}$. - 4 x Washers $\varnothing 10 \times \varnothing 16 \times 0.2 \text{mm}$. - 4 x Orings 3050. 	<p>Battery Tray [H0149-S]</p>  <ul style="list-style-type: none"> - 1 x Battery Plate. - 1 x Battery Protection. - 2 x Cylinder M2.5. - 2 x Flat Head Cap Screw M2.5x5mm - 1 x Heat Shrink. 	<p>Stop Battery Tray [H0150-S]</p>  <ul style="list-style-type: none"> - 1 x Stop Battery Tray. - 2 x Socket Head Cap Screw M2.5x8mm. 	<p>Carbon Fiber ESC Support (H0153-S)</p>  <ul style="list-style-type: none"> - 1 x Carbon Fiber ESC Support. - 6 x Flat Head Socket Cap M2,5x5mm.
<p>19T Drive Pinion [H0156-S]</p>  <ul style="list-style-type: none"> - 1 x 19T Drive Pinion. - 1 x Socket Head Cap Screw Shouldered M3x22mm. - 1 x Metric Hex Nylon Nut M3H4. 	<p>Secondary Shaft [H0157-S]</p>  <ul style="list-style-type: none"> - 1 x Secondary Shaft M3. - 1 x Socket Head Cap Screw Shoulder M2.5x19mm. - 1 x Metric Hex Nylon Nut M2,5H3,5. - 1 x Socket Head Cap Shoulder M3x22mm. - 1 x Metric Hex locknut Nuts M3H4. 	<p>Aluminum Blade Spacer [H0158-S]</p>  <ul style="list-style-type: none"> - 4 x Aluminum Blade Spacer 	<p>Canopy Positioner [H0159-S]</p>  <ul style="list-style-type: none"> - 2 x Canopy Positioner. - 2 x Socket Head Cap Screws M3x10mm.
<p>Red Landing Gear [H0162-S]</p>  <ul style="list-style-type: none"> - 1 x CF Red Landing Gear. 	<p>Double Bearing One Way Pulley [H0171-S]</p>  <ul style="list-style-type: none"> - 1 x Aluminum Double Bearing One Way Pulley. - 3 x Shims $\varnothing 10 \times \varnothing 16 \times 0.2 \text{mm}$. - 1 x One Way Brass Bushing. 	<p>Aluminum Front Tail Pulley [H0172-S]</p>  <ul style="list-style-type: none"> - 1 x Aluminum Front Tail Pulley. - 1 x Socket Head Cap M2.5x19mm. - 1 x Metric Hex Nylon Nuts M2,5H3,5. 	
<p>Belt Tensioner Support [H0174-S]</p>  <ul style="list-style-type: none"> - 1 x Column Belt Tensioner. - 1 x Tail Belt Idler. - 1 x Belt Tensioner Arm. - 2 x Flanged Bearings $\varnothing 3 \times \varnothing 7 \times 3 \text{mm}$. - 2 x Flanged Bearings $\varnothing 5 \times \varnothing 9 \times 3 \text{mm}$. - 1 x Socket Head Cap Screw M3x50mm. - 1 x Washer $\varnothing 3 \times \varnothing 4 \times 0.5 \text{mm}$. - 1 x Socket Head Cap Screw M3x12mm. - 2 x Washers $\varnothing 3.2 \times \varnothing 6 \times 0.5 \text{mm}$. - 1 x Button Head Cap Screw M3x4mm. - 1 x Spring De8/df0.5/LL8. 	<p>18T Pulley [H0175-18-S]</p>  <ul style="list-style-type: none"> - 1 x 18T Pulley. - 1 x Set Screws M4x4mm. 	<p>19T Pulley [H0175-19-S]</p>  <ul style="list-style-type: none"> - 1 x 19T Pulley. - 1 x Set Screws M4x4mm. 	

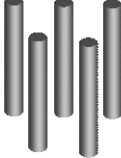

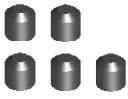
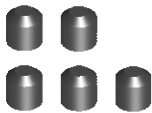
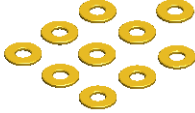
<p>20T Pulley [H0175-20-S]</p>  <ul style="list-style-type: none"> - 1 x 20T Pulley. - 1 x Set Screws M4x4mm. 	<p>21T Pulley [H0175-21-S]</p>  <ul style="list-style-type: none"> - 1 x 21T Pulley. - 1 x Set Screws M4x4mm. 	<p>22T Pulley [H0175-22-S]</p>  <ul style="list-style-type: none"> - 1 x 22T Pulley. - 1 x Set Screws M4x4mm. 	<p>23T Pulley [H0175-23-S]</p>  <ul style="list-style-type: none"> - 1 x 23T Pulley. - 1 x Set Screws M4x4mm.
<p>24T Pulley [H0175-24-S]</p>  <ul style="list-style-type: none"> - 1 x 24T Pulley. - 1 x Set Screws M4x4mm. 	<p>Blade Grip [H0182-S]</p>  <ul style="list-style-type: none"> - 2 x Blade Grip. - 2 x Thrust Bearing $\varnothing 10 \times \varnothing 18 \times 5.5 \text{mm}$. - 4 x Bearing $\varnothing 10 \times \varnothing 19 \times 5 \text{mm}$. - 2 x Washer $\varnothing 10 \times \varnothing 16 \times 1 \text{mm}$. - 2 x Button Head Socket Cap M4x10mm. 	<p>Blade Grip Arm [H0183-S]</p>  <ul style="list-style-type: none"> - 2 x Blade Grip Arm. - 2 x Socket Head Cap Screw M4x10mm. - 2 x Uniball M3x4 $\varnothing 5 \text{H}3.5$. 	<p>Plastic Tail Linkage [H0261-S]</p>  <ul style="list-style-type: none"> - 1 x Plastic Tail Linkage. - 1 x Grip Link Bushing. - 1 x Socket Head Cap Screws M2x6mm.
<p>Quick Release Canopy Mount [H0319-S]</p>  <ul style="list-style-type: none"> - 2 x Quick Release Canopy Assembly. - 2 x Flat Head Socket Cap M3x8mm. - 2 x Canopy Grommets. 	<p>Steel Tail Shaft [H0325-S]</p>  <ul style="list-style-type: none"> - 1 x Steel Tail Shaft Assembly. - 1 x Tail Oring Damperner. 	<p>Aluminum Tail Blade Grip [H0327-S]</p>  <ul style="list-style-type: none"> - 2 x Aluminum Tail Blade Grip. - 4 x Bearing $\varnothing 5 \times \varnothing 10 \times 4 \text{mm}$. - 2 x Thrust bearing $\varnothing 5 \times \varnothing 10 \times 4 \text{mm}$. - 2 x Button Head Cap M4x8mm. - 2 x Socket Head Cap M2x6mm. - 2 x Washer $\varnothing 5 \times \varnothing 8.9 \times 0.75 \text{mm}$. - 2 x Washer $\varnothing 7.5 \times \varnothing 10 \times 0.5 \text{mm}$. 	<p>Tail Spilde Shaft [H0329-S]</p>  <ul style="list-style-type: none"> - 1 x Tail Spilde Shaft - 2 x Button Head Socket Cap M4x6mm.
<p>Spacer Set For Tail Rotor [H0330-S]</p>  <ul style="list-style-type: none"> - 2 x Washer $\varnothing 5 \times \varnothing 8.9 \times 0.75 \text{mm}$. - 2 x Washer $\varnothing 7.5 \times \varnothing 10 \times 0.5 \text{mm}$. - 2 x Tail Oring Damperner. 	<p>Linkage HPS V2 [H0346-S]</p>  <ul style="list-style-type: none"> - 2 x Linkage HPS. - 4 x Plastic Ball Link. - 2 x Linkage Rod. 	<p>Main Frame [H0354-S]</p>  <ul style="list-style-type: none"> - 1 x Main Frame. 	<p>Yellow Tail Boom [H0355-S]</p>  <ul style="list-style-type: none"> - 1 x Yellow Tail Boom. - 2 x Locking Element Tails. - 2 x Double-Sided Tapes. - 1 x Set Screws M3 x 20mm. - 2 x Washers 3.1 x 12 x 1.8mm. - 4 x Metric Hex Nylon Nuts M3. - 2 x Boom spacers. - 2 x Socket Head Cap Screws M3 x 12mm. - 2 x Nylon Screw M8x20mm. - 1 x Flat Head Cap Screws M3x8mm.
<p>Canopy Yellow/Orange. [H0356-S]</p>  <ul style="list-style-type: none"> - 1 x Canopy Yellow/Orange. - 1 x Canopy Grommet. - 1 x Canopy mousse. - 1 x Canopy Edge Protection. 	<p>Canopy Yellow/Green. [H0357-S]</p>  <ul style="list-style-type: none"> - 1 x Canopy Yellow/Green. - 1 x Canopy Grommet. - 1 x Canopy mousse. - 1 x Canopy Edge Protection. 	<p>Tail Boom Support [H0358-S]</p>  <ul style="list-style-type: none"> - 1 x Tail Boom Support. - 1 x Nylon screw M8x20mm. - 1 x Flat Head Socket Cap M3x8mm. 	<p>Aluminum Tail Side Plate [H0359-S]</p>  <ul style="list-style-type: none"> - 1 x Aluminum Tail Side Plate. - 1 x Flanged bearing $\varnothing 6 \times \varnothing 13 \times 5 \text{mm}$.

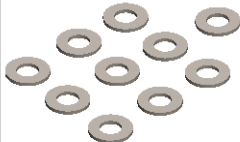
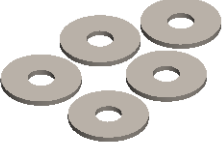

<p>[HC002-S]</p>  <p>- 5 x Socket Head Cap Screws M2x5mm.</p>	<p>[HC004-S]</p>  <p>- 5 x Socket Head Cap Screws M2x6mm.</p>	<p>[HC008-S]</p>  <p>- 5 x Socket Head Cap Screws M2x8mm.</p>	<p>[HC010-S]</p>  <p>- 5 x Socket Head Cap Screws M2x10mm.</p>	<p>[HC018-S]</p>  <p>- 5 x Socket Head Cap Screws M2.5x6mm.</p>	<p>[HC020-S]</p>  <p>- 5 x Socket Head Cap Screws M2.5x8mm.</p>
<p>[HC026-S]</p>  <p>- 5 x Socket Head Cap Screw M2.5x12mm.</p>	<p>[HC033-S]</p>  <p>- 4 x Socket Head Cap shoulder M2.5x19mm. - 4 x Metrix Hex Nylon Nut M2.5.</p>	<p>[HC038-S]</p>  <p>- 5 x Button Head Cap Screws M3x4mm.</p>	<p>[HC044-S]</p>  <p>- 5 x Socket Head Cap Screws M3x6mm.</p>	<p>[HC050-S]</p>  <p>- 5 x Socket Head Cap Screws M3x8mm.</p>	<p>[HC056-S]</p>  <p>- 5 x Socket Head Cap Screws M3x10mm.</p>
<p>[HC062-S]</p>  <p>- 5 x Socket Head Cap Screws M3x12mm.</p>	<p>[HC068-S]</p>  <p>- 5 x Socket Head Cap Screws M3x16mm.</p>	<p>[HC079-S]</p>  <p>- 5 x Socket Head Cap Shoulder M3x18mm.</p>	<p>[HC086-S]</p>  <p>- 5 x Socket Head Cap Screws M3x22mm.</p>	<p>[HC091-S]</p>  <p>- 2 x Socket Head Cap Shoulders M3x40mm.</p>	<p>[HC096-S]</p>  <p>- 5 x Button Head Cap Screws M4x6mm.</p>
<p>[HC098-S]</p>  <p>- 5 x Button Head Cap Screws M4x8mm.</p>	<p>[HC100-S]</p>  <p>- 5 x Button Head Cap Screws M4x10mm.</p>	<p>[HC102-S]</p>  <p>- 5 x Socket Head Cap Screws M4x10mm.</p>	<p>[HC104-S]</p>  <p>- 5 x Socket Head Cap Screws M4x22mm.</p>	<p>[HC111-S]</p>  <p>- 2 x Socket Head Cap Shoulder M5x30mm. - 2 x Metrix Hex Nut M5.</p>	<p>[HC116-S]</p>  <p>- 2 x Socket Head Cap Shoulder M5x35mm. - 2 x Metrix Hex Nut M5.</p>
<p>[HC122-S]</p>  <p>- 5 x Button Head Cap Screws M6x10mm.</p>	<p>[HC128-S]</p>  <p>- 5 x Flat Head Cap Screws M2.5x5mm.</p>	<p>[HC134-S]</p>  <p>- 5 x Flat Head Cap Screws M3x8mm.</p>	<p>[HC140-S]</p>  <p>- 5 x Cup Point Set Screws M2.5x20mm.</p>	<p>[HC150-S]</p>  <p>- 5 x Cup Point Set Screws M3x20mm.</p>	<p>[HC152-S]</p>  <p>- 5 x Cup Point Set Screws M4x4mm.</p>
<p>[HC153-S]</p>  <p>- 5 x Cup Point Set Screws M4x6mm.</p>	<p>[HC170-S]</p>  <p>- 10 x Washer Ø2,2xØ5x0,3mm.</p>	<p>[HC176-S]</p>  <p>- 5 x Washer Ø3xØ4x0,5mm.</p>	<p>[HC180-S]</p>  <p>- 10 x Washer Ø3.3xØ6x0,5mm.</p>	<p>[HC188-S]</p>  <p>- 5 x Washer Ø5.3xØ15x1mm.</p>	<p>[HC194-S]</p>  <p>- 5 x Washer Ø6.3xØ15x1mm.</p>





<p>[HC200-S]</p>  <p>- 10 x Metric Hex Nylon Nuts M2,5H3,5.</p>	<p>[HC206-S]</p>  <p>- 10 x Metric Hex Nylon Nuts M3H4.</p>	<p>[HC212-S]</p>  <p>- 10 x Metric Hex Nylon Nuts M4H5.</p>	<p>[HC218-S]</p>  <p>- 5 x Metric Hex Nylon Nuts M5H4,5.</p>	
<p>[HC230-S]</p>  <p>- 5 x Shims Ø10xØ16x1mm.</p>	<p>[HC232-S]</p>  <p>- 5 x Shims Ø10xØ16x0.2mm.</p>	<p>[HC239-S]</p>  <p>- 1 x Carbon Rod Ø4xØ2,5x702mm. - 2 x Plastic Ball Linkage. - 2 x Thread Rod M2.5x40mm.</p>	<p>[HC242-S]</p>  <p>- 3 X Thread Rods M2.5 x 40mm.</p>	<p>[HC304-S]</p>  <p>- 1 x Main Belt.</p>
<p>[HC309-S]</p>  <p>- 1 x Motor Belt 240-3MGT 19mm.</p>	<p>[HC315-S]</p>  <p>- 2 x Spring 5,8/df 0,3/LL 9. - 1 x Spring 8 /df 0,5 / LL 8. - 2 x Spring 3 /df 5 / LL 12.</p>	<p>[HC335-S]</p>  <p>- 4 x Tail Oring Dampener.</p>	<p>[HC400-S]</p>  <p>- 4 x Flanged Bearings Ø2.5x Ø6x2.6mm.</p>	<p>[HC402-S]</p>  <p>- 4 x Flanged Bearings Ø3x Ø7x3mm.</p>
<p>[HC410-S]</p>  <p>- 4 x Flanged Bearings Ø5x Ø9x3mm.</p>	<p>[HC411-S]</p>  <p>- 4 x Bearings Ø5x Ø10x4mm.</p>	<p>[HC414-S]</p>  <p>- 2 x Flanged Bearings Ø6x Ø13x4mm.</p>	<p>[HC418-S]</p>  <p>- 2 x Flanged Bearings Ø8x Ø12x3.5mm.</p>	<p>[HC420-S]</p>  <p>- 2 x Bearings Ø10x Ø15x4mm.</p>
<p>[HC422-S]</p>  <p>- 4 x Bearings Ø10x Ø19x5mm.</p>	<p>[HC426-S]</p>  <p>- 2 x Bearings Ø12x Ø24x6mm.</p>	<p>[HC430-S]</p>  <p>- 2 x Rad Bearings Ø30x Ø37x4mm.</p>	<p>[HC435-S]</p>  <p>- 2 x Thrust Bearings Ø5x Ø10x4mm.</p>	<p>[HC438-S]</p>  <p>- 2 x Thrust Bearings Ø10x Ø18x5.5mm.</p>
<p>[HC442-S]</p>  <p>- 1 x One Way Bearings Ø10x Ø14x12mm.</p>	<p>[HA001-S]</p>  <p>- 1 x Foam Blade Holder</p>	<p>[HA002-S]</p>  <p>- 2 x Hex Wrenches 2,5.</p>	<p>[HA006-S]</p>  <p>- 1 x Canopy Mousse.</p>	<p>[HA010-S]</p>  <p>- 2 x Cable Pass.</p>



<p>[HA016-S]</p>  <p>- 2 x Wrench Tool M8,M6.</p>	<p>[HA024-S]</p>  <p>- 4 x O-ring 3050.</p>	<p>[HA025-S]</p>  <p>- 2 x Velcro Battery Strap.</p>	<p>[HA026-S]</p>  <p>- 8 x Heat Shrink - Clear.</p>	<p>[HA112-S]</p>  <p>- 1 x Rubber Canopy Edge Protection.</p>
--	--	---	---	--

UPGRADES and ACCESSORIES

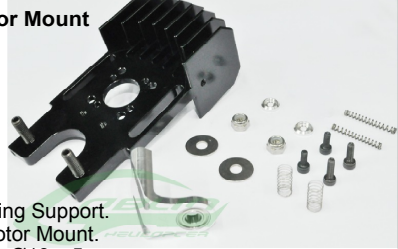
<p>New Heavy-Duty Tail Pulley 27T [H0103-S]</p>  <p>1 x New Heavy-Duty Tail Pulley 27T</p>	<p>Aluminum ESC Heat Sink [H0165-S]</p>  <ul style="list-style-type: none"> - 1 x Aluminum ESC Heat Sink. - 4 x Socket Head Cap M3x6mm. - 4 x Cup Point Set Screws M3X20mm. - 12 x Washer Ø3,3xØ6x0,5mm. - 4 x Metric hex locknut Nuts M3H4. 	<p>Aluminum Cooling Motor Mount [H0316-S]</p>  <ul style="list-style-type: none"> - 1 x Aluminum Third Bearing Support. - 1 x Aluminum Cooling Motor Mount. - 1 x Flanged Bearing Ø6 x Ø13 x 5mm. - 2 x Socket Head Cap Screw M3x8mm. - 2 x Aluminum Finishing Washers. - 2 x Spring 5.8 / 0.3 / LL 9. - 2 x Spring 3 / 0.5 / LL 12.
--	---	---

<p>Strong Main Gear G700. [H0320-S]</p>  <ul style="list-style-type: none"> - 1 x Strong Main Gear (Set). - 1 x Pinion (Set). 	<p>SAB HELIDIVISION Futaba Servo Horn [HA050]</p>  <p>- 1 x Plastic Servo Horn.</p>	<p>SAB HELIDIVISION JR Servo Horn [HA050]</p>  <p>- 4 x JR Servo Horn.</p>	<p>SAB HELI DIVISION New Black T-shirt [HM025-S-M-L-XL-XXL]</p>  <p>- SAB HELI DIVISION New Black T-shirt.</p>
---	---	---	--

<p>SAB HELI DIVISION Black Polo Shirt [HM027-S-M-L-XL-XXL]</p>  <p>- SAB HELI DIVISION Black Polo Shirt.</p>	<p>SAB HELI DIVISION Black Hoodies [HM029-S-M-L-XL-XXL]</p>  <p>- SAB HELI DIVISION Black Hoodies.</p>	<p>SAB HELI DIVISION Neck Strap [HM034]</p>  <p>- 1 x Neck Strap.</p>
--	--	---

<p>SAB HELI DIVISION Decal [HM035]</p>  <p>- 1 x SAB HELI DIVISION Decal (set).</p>	<p>SAB HELI DIVISION Keychain [HM037]</p>  <p>- 1 x SAB HELI DIVISION Keychain.</p>	<p>SAB HELI DIVISION Stand [HM038]</p>  <p>- 1 x SAB HELI DIVISION Stand (Set).</p>
---	--	---

WWW.GOBLIN-HELICOPTER.COM

SAB HELI DIVISION