



Goblin 630 Manual

Goblin 630 Manual

Release 1.1 - July 2012

SAB HELI DIVISION S.R.L.

Via San Crispino, 47

47030 San Mauro Pascoli (FC) - ITALY



INDEX

- | | | |
|------------------------------|---|-------------------------------|
| 1 – Introduction | 7 – Tail assembly | 13 – Installation of the boom |
| 2 – Important notes ⚠ | 8 – Assembling the modules | 14 – Battery and Canopy |
| 3 – Components and Box | 9 – Installation of swashplate servos | 15 – In flight ⚠ |
| 4 – Carbon frame assembly | 10 – Installation of the ESC | 16 – Maintenance |
| 5 – Transmission module | 11 – Installation of Flybarless unit and RX | 17 – Exploded views |
| 6 – Main rotor | 12 – Installation of the motor | 18 – Spare parts |

SPECIFICATIONS

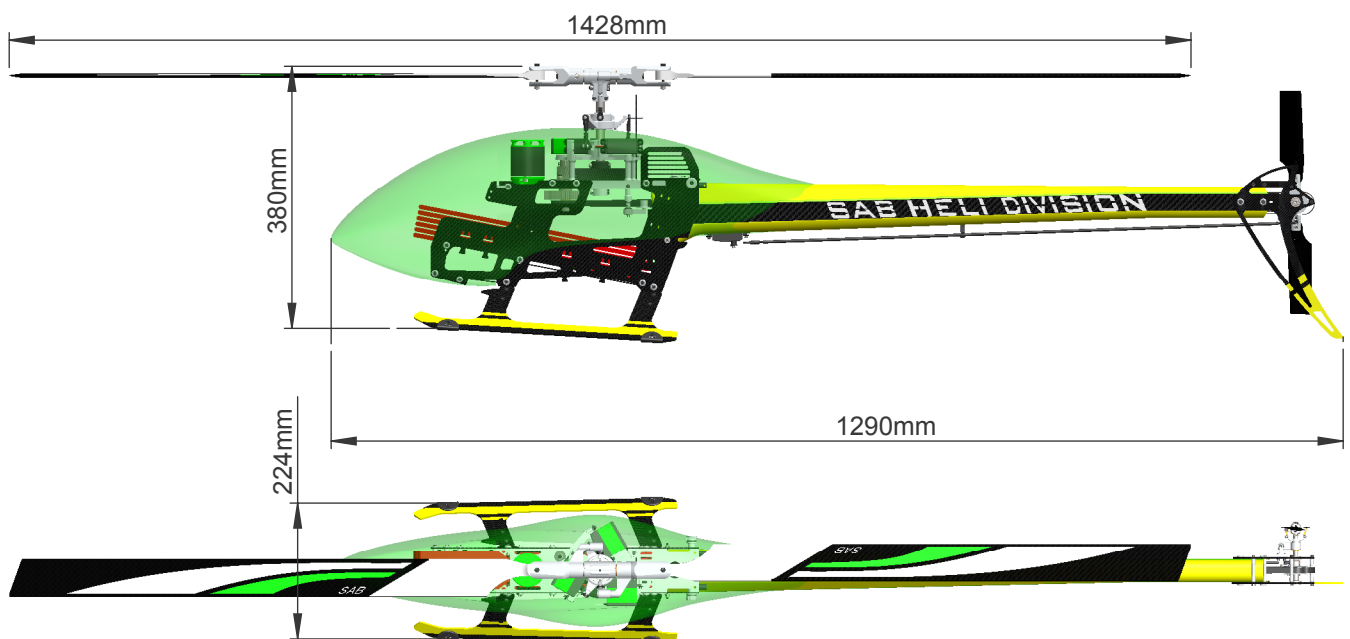

Main rotor diameter: 1428mm (with 630mm blades)
 Main blade length: 600 to 630mm
 Tail rotor diameter: 278mm
 Tail blade length: 105mm
 Main shaft diameter: 12mm
 Tail shaft diameter: 6mm
 Spindle diameter: 10mm

Weight including standard electronics: 3220g (excluding batteries).
 Motor size: Maximum 64mm diameter, maximum height 64mm
 Battery compartment: 60x58x350mm (adaptable to 64x58x350mm)

SAB HELI DIVISION

The Goblin is a high performance radio controlled helicopter.
 The design is original, moving away from traditional schemes, searching rationality for simplicity.
 Our goal was to create a simple, high performance helicopter, with a minimum of mechanical components, and simple maintenance.
 Please read this user manual carefully, it contains instructions for the correct assembly of the model.
Please refer to the web site www.goblin-helicopter.com for updates and other important information.
 Thank you for your purchase, and have a great time with your Goblin!

SAB Heli Division.

SAB HELI DIVISION



IMPORTANT NOTES

- *This radio controlled helicopter is not a toy.
- *This radio controlled helicopter can be very dangerous.
- *This radio controlled helicopter is a technically complex device which has to be built and handled very carefully.
- *This radio controlled helicopter must be built following these instructions. This manual provides the necessary information to correctly assemble the model. It is necessary to carefully follow all the instructions.
- *Inexperienced pilots must be monitored by expert pilots.
- *All operators must wear safety glasses and take appropriate safety precautions.
- *A radio controlled helicopter must only be used in open spaces without obstacles, and far enough from people to minimize the possibility of accidents or of injury to property or persons.
- *A radio controlled helicopter can behave in an unexpected manner, causing loss of control of the model, making it very dangerous.
- *Lack of care with assembly or maintenance can result in an unreliable and dangerous model.

Neither SAB Heli Division nor its agents have any control over the assembly, maintenance and use of this product. Therefore, no responsibility can be traced back to the manufacturer. You hereby agree to release SAB Heli Division from any responsibility or liability arising from the use of this product.

SAFETY GUIDELINES

- *Fly only in areas dedicated to the use of model helicopters.
- *Follow all control procedures for the radio frequency system.
- *It is necessary that you know your radio system well. Check all functions of the transmitter before every flight.
- *The blades of the model rotate at a very high speed; be aware of the danger they pose and the damage they may cause.
- *Never fly in the vicinity of other people.

NOTES FOR ASSEMBLY

Please refer to this manual for assembly instructions for this model.

Follow the order of assembly indicated. The instructions are divided into chapters, which are structured in a way that each step is based on the work done in the previous step. Changing the order of assembly may result in additional or unnecessary steps.

Use thread lockers and retaining compounds as indicated. In general, each bolt or screw that engages with a metal part requires thread lock.

Factory pre-assembled components have been assembled with all the required thread lock and lubricants, and have passed quality control. It is not necessary to disassemble and re-assemble them.

It is necessary to pay attention to the symbols listed below:

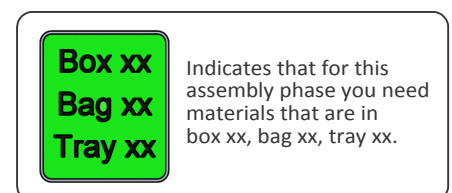
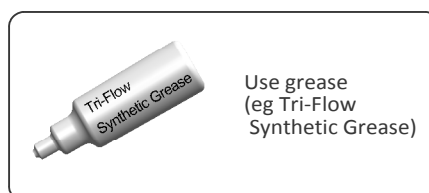
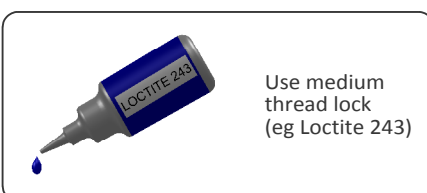
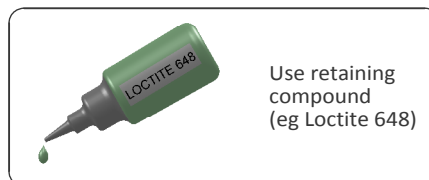
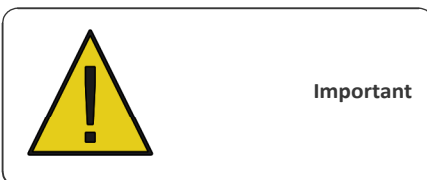



ADDITIONAL COMPONENTS REQUIRED

- *Electric Motor:
10S-12S – 400-650Kv
Maximum diameter 64mm,
Maximum height 64mm, pinion shaft diameter 6mm
- *Speed controller:
minimum 80A to be safe
- *Batteries: 10-12S 3300-4000mAh
- *1 flybarless 3 axis control unit
- *Radio power system, if not integrated with the ESC
- *3 cyclic servos
- *1 tail rotor servo
- *6 channel radio control system on 2.4 GHz

(See configuration examples on page 28)

TOOLS, LUBRICANTS, ADHESIVES

- *Generic pliers
- *Hexagonal driver, size 1.5,2,2.5,3,4mm
- *4mm T-Wrench
- *5.5mm Socket wrench (for M3 nuts)
- *8mm Hex fork wrench (for M5 nuts)
- *Medium threadlocker (eg. Loctite 243)
- *Strong retaining compound (eg. Loctite 648)
- *Spray lubricant (eg. Try-Flow Oil)
- *Synthetic grease (eg. Tri-Flow Synthetic Grease)
- *Cyanoacrylate adhesive

- *Pitch Gauge (for set-up)
- *Soldering equipment (for motor wiring)

Inside the main box there are:

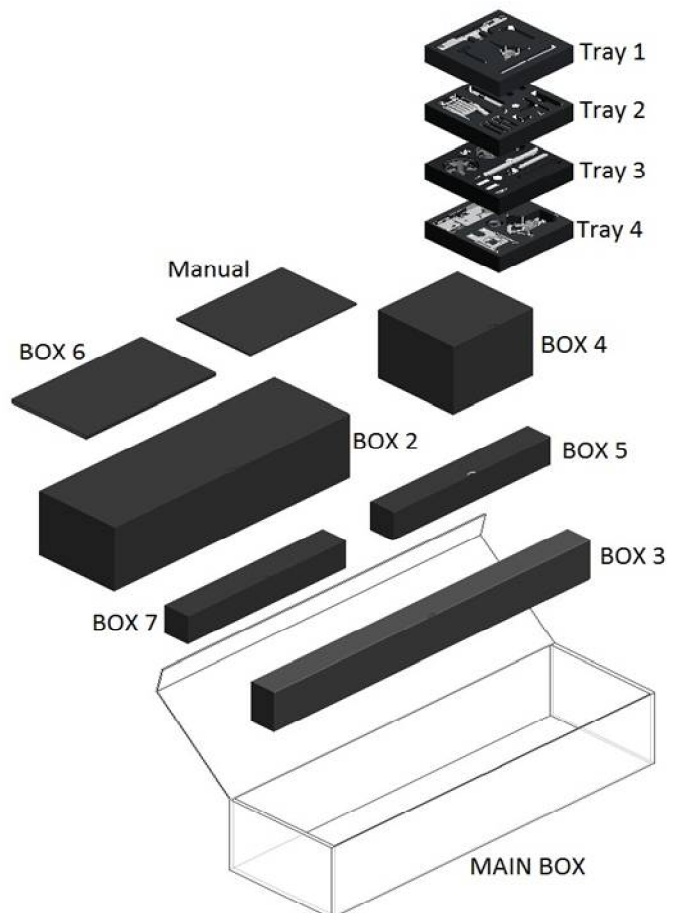

Inside the main box:

- Box 2: Canopy, Blade Holder.
- Box 3: Boom, Blades, Tail blades, Carbon rod.
- Box 4: Mechanical parts in 4 trays:
Tray 1: Main rotor
Tray 2: Carbon frame and tail rotor
Tray 3: Transmission
Tray 4: Main structure
- Box 5: Bags
- Box 6: Carbon parts
- Box 7: Combo Kit (optional)

The assembly process is described in the following chapters of this manual. Each phase begins with a green frame which gives the box, the bag with screws (and miscellaneous items), and the foam tray with the components required for the phase.



4-Carbon Frame



The manufacturing process of the carbon parts often leaves micro-burrs and sharp edges. We recommend de-burring the edges to minimize the risks of electrical wire cuts, etc.

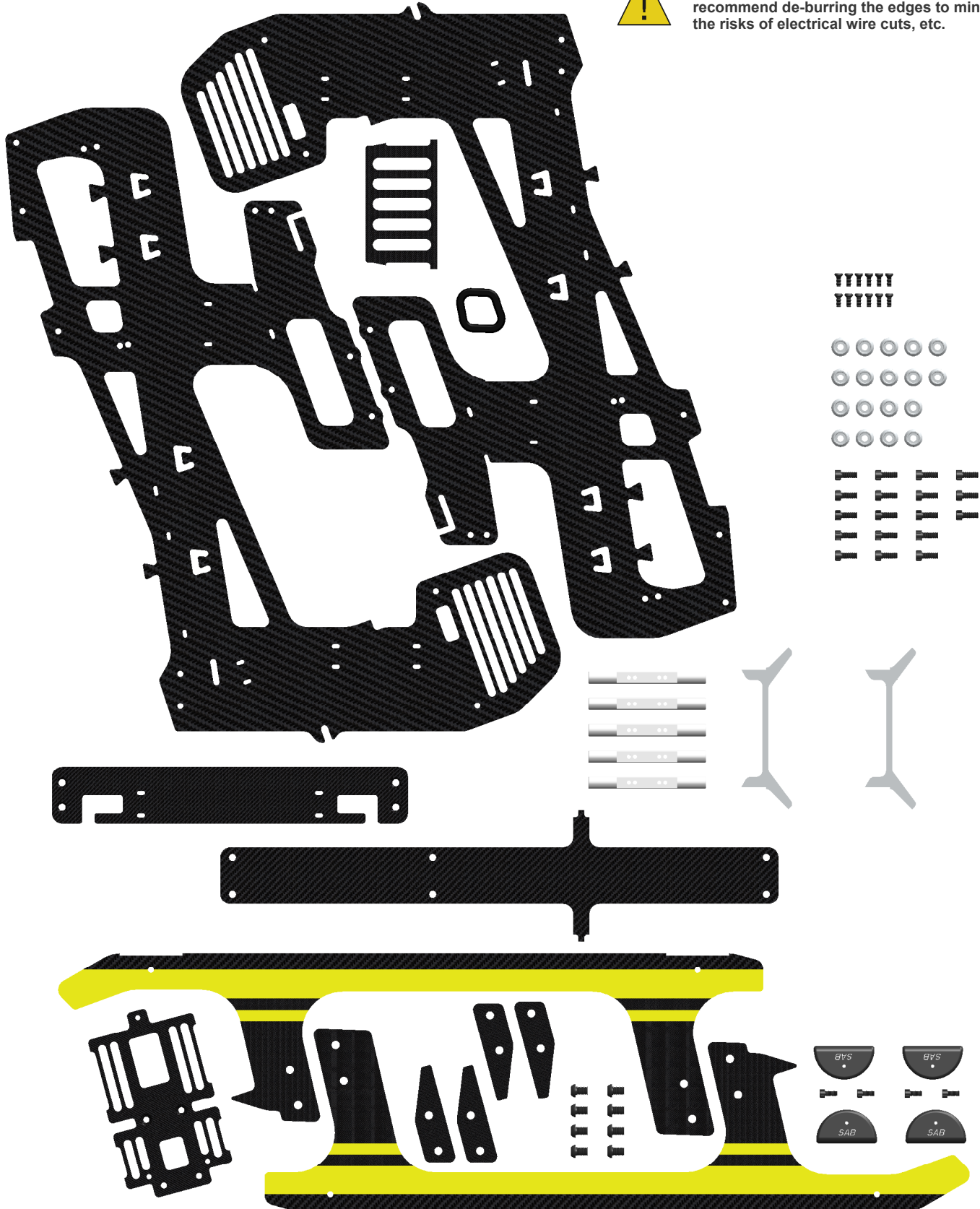



Box 6
Bag 1
Tray 2

Frame Spacer x 3

Note:

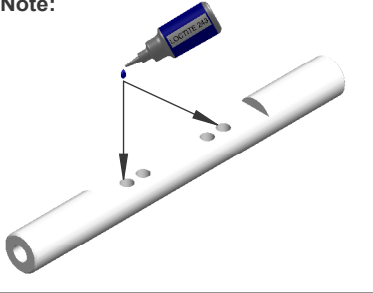

Flat Head Cap Screw
M2.5x5mm

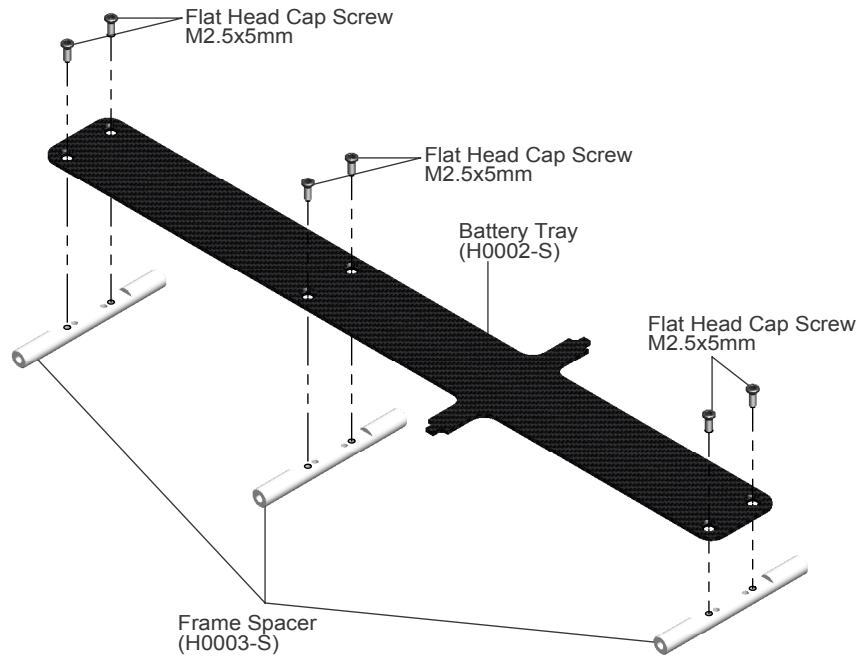

Box 6
Bag 1

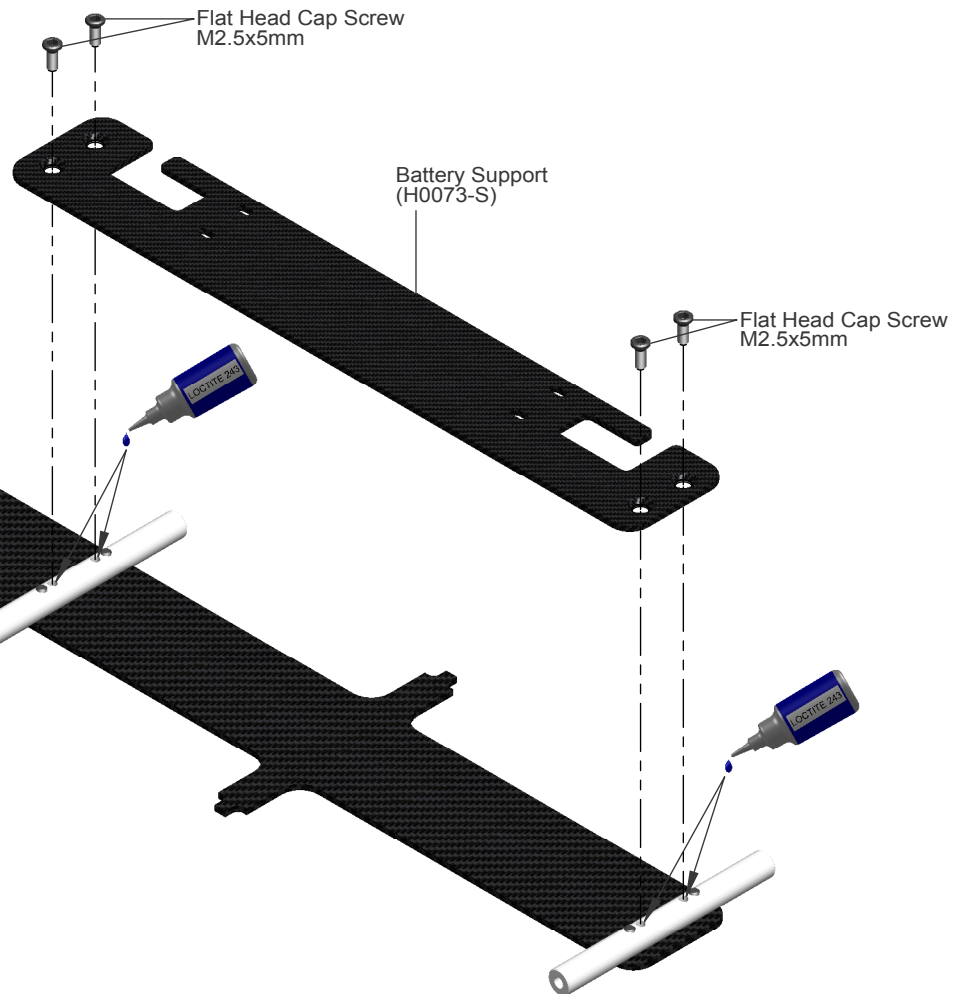

Flat Head Cap Screw
M2.5x5mm





Box 6
Bag 1
Tray 2

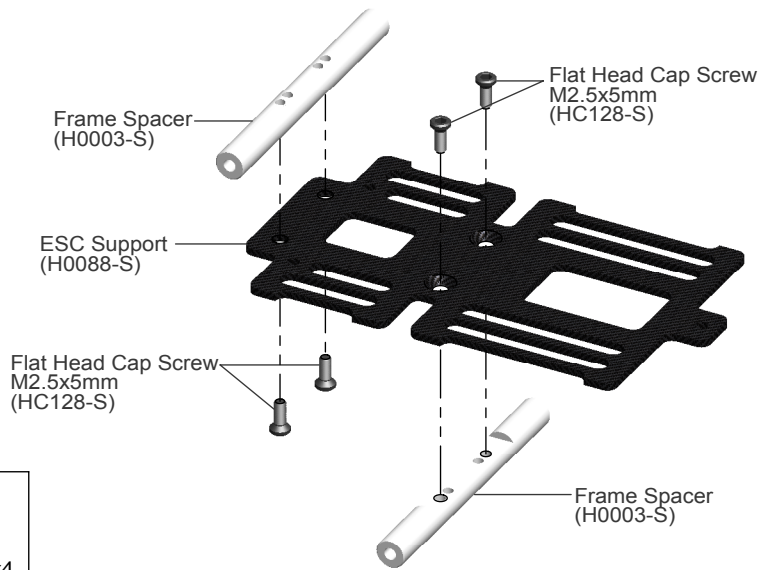

Flat Head Cap Screw M2.5x5mm

x4

Note:

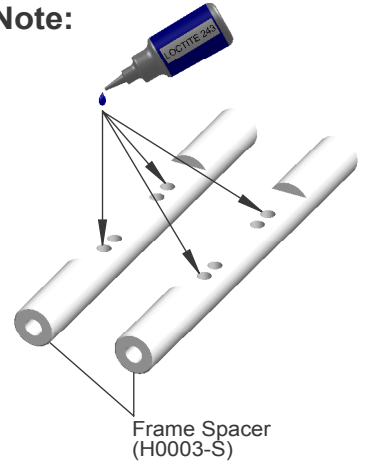

Box 6
Bag 1
Tray 2

Note:

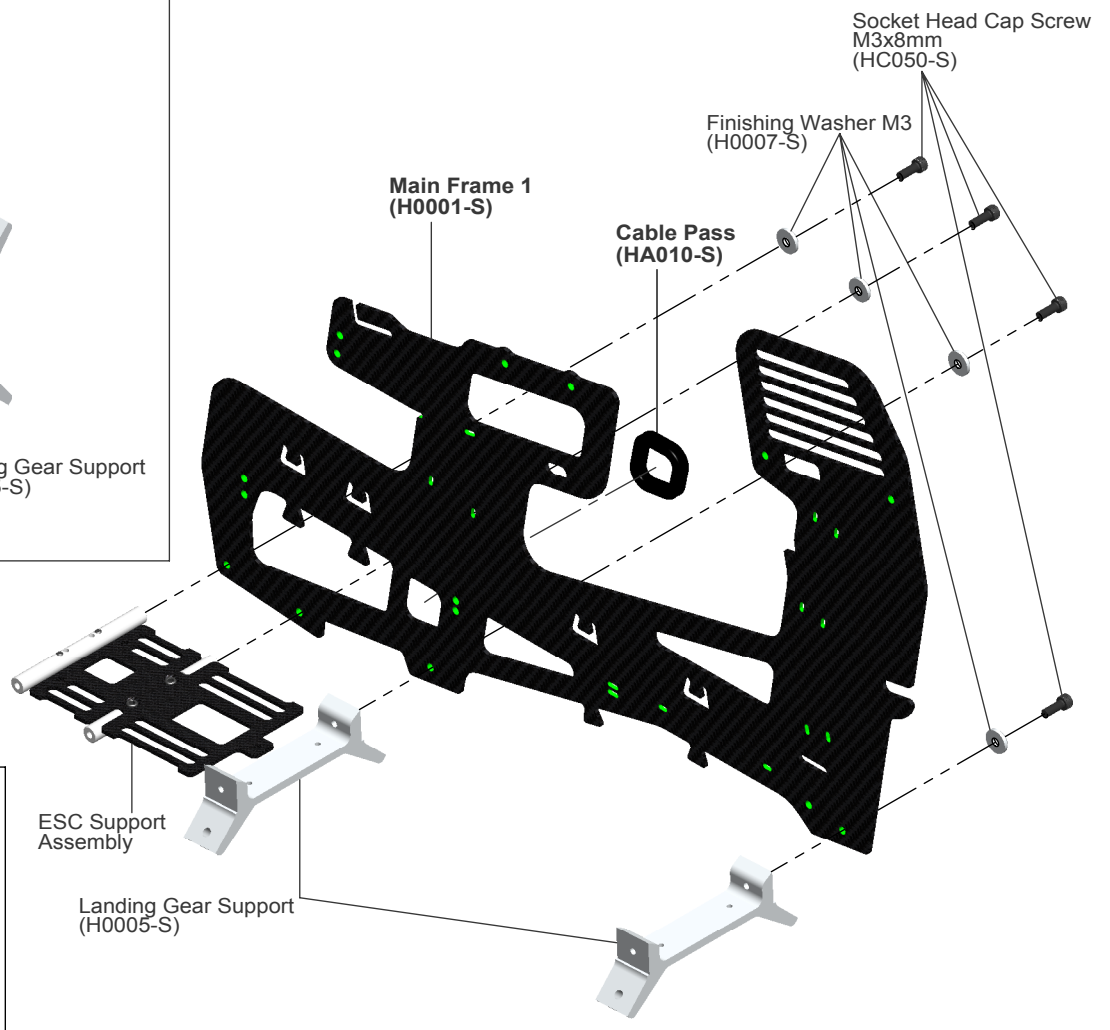
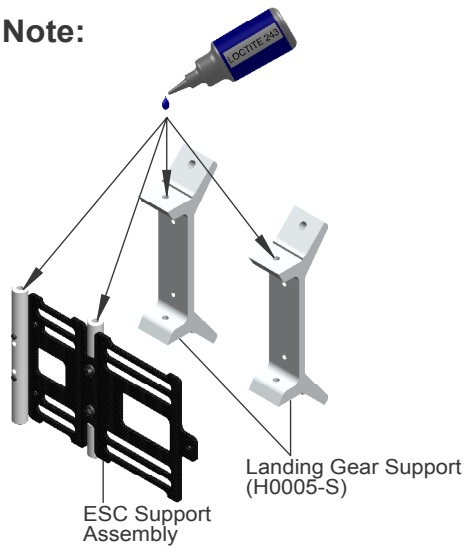

Socket Head Cap Screw M3x8mm

x4

Finishing Washer M3

x4



Bag 1

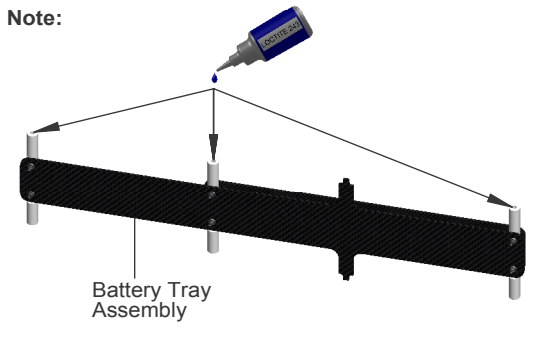
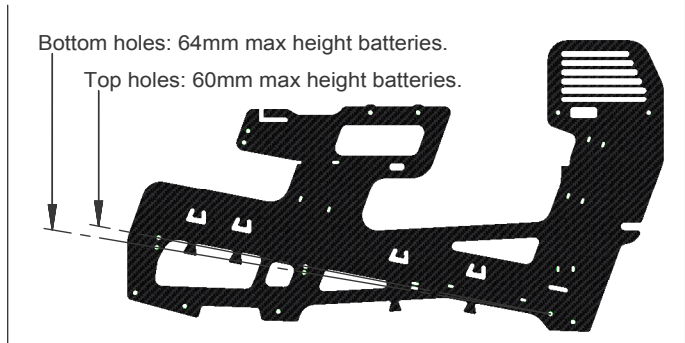

- Socket Head Cap Screw M3x8mm
- x3
- Finishing Washer M3
- x3

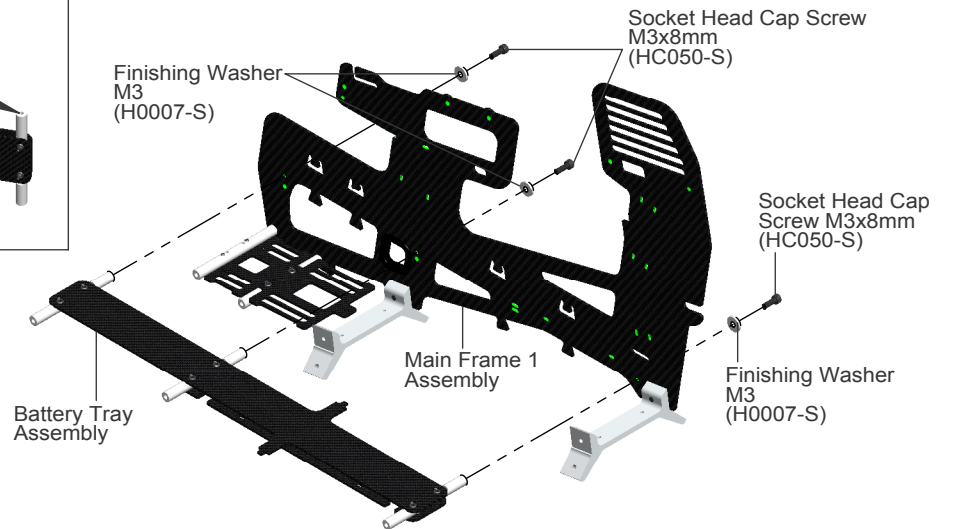

Box 6 Bag 1

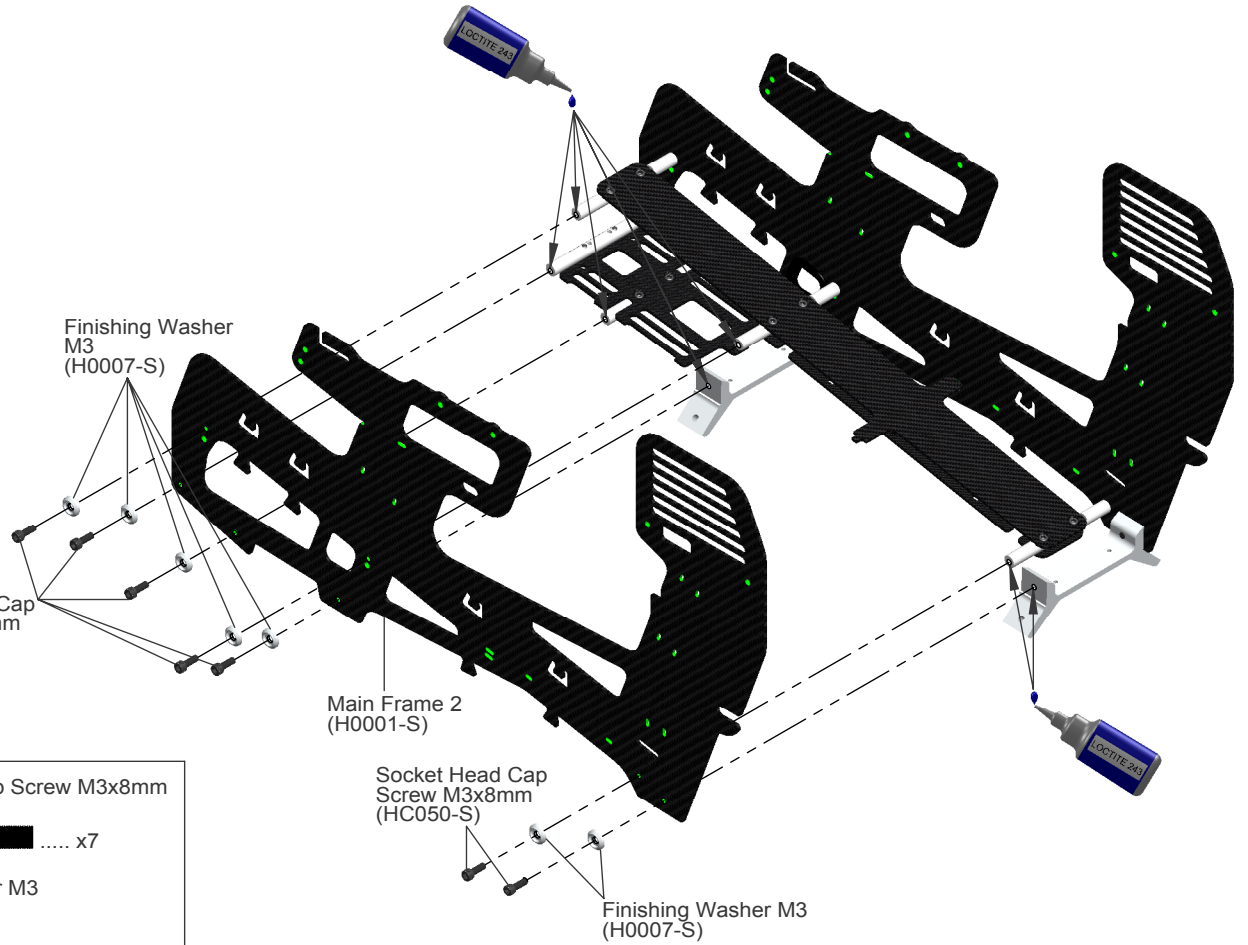

- Socket Head Cap Screw M3x8mm
- x7
- Finishing Washer M3



**Box 6
Bag 2**

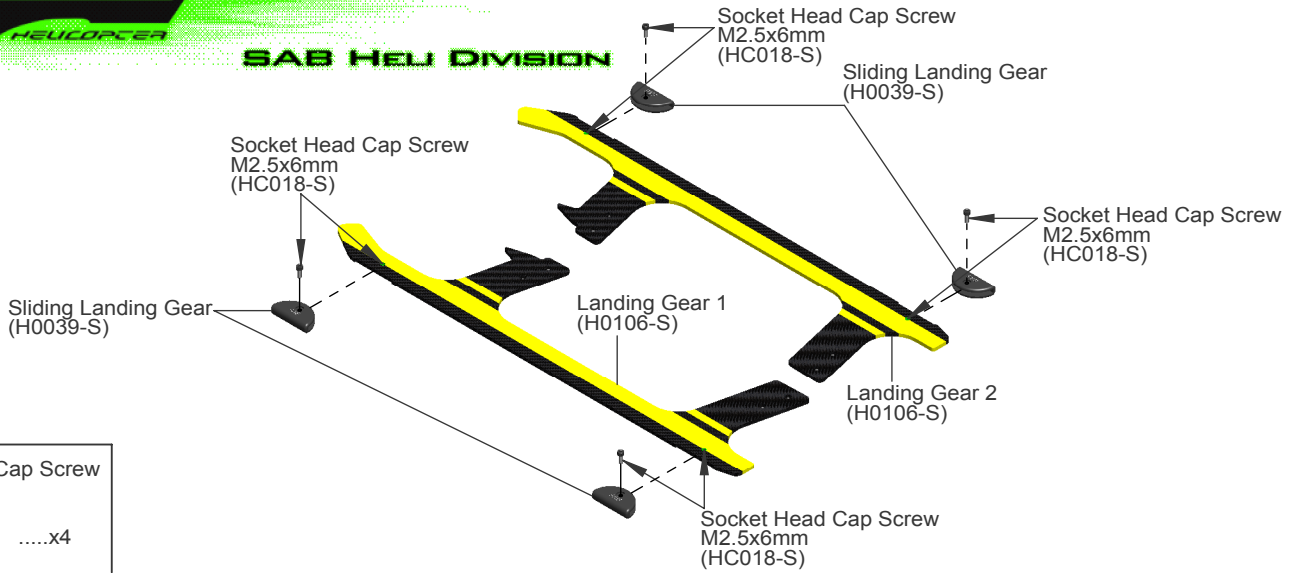

Socket Head Cap Screw M2.5x6mm



Bag 2

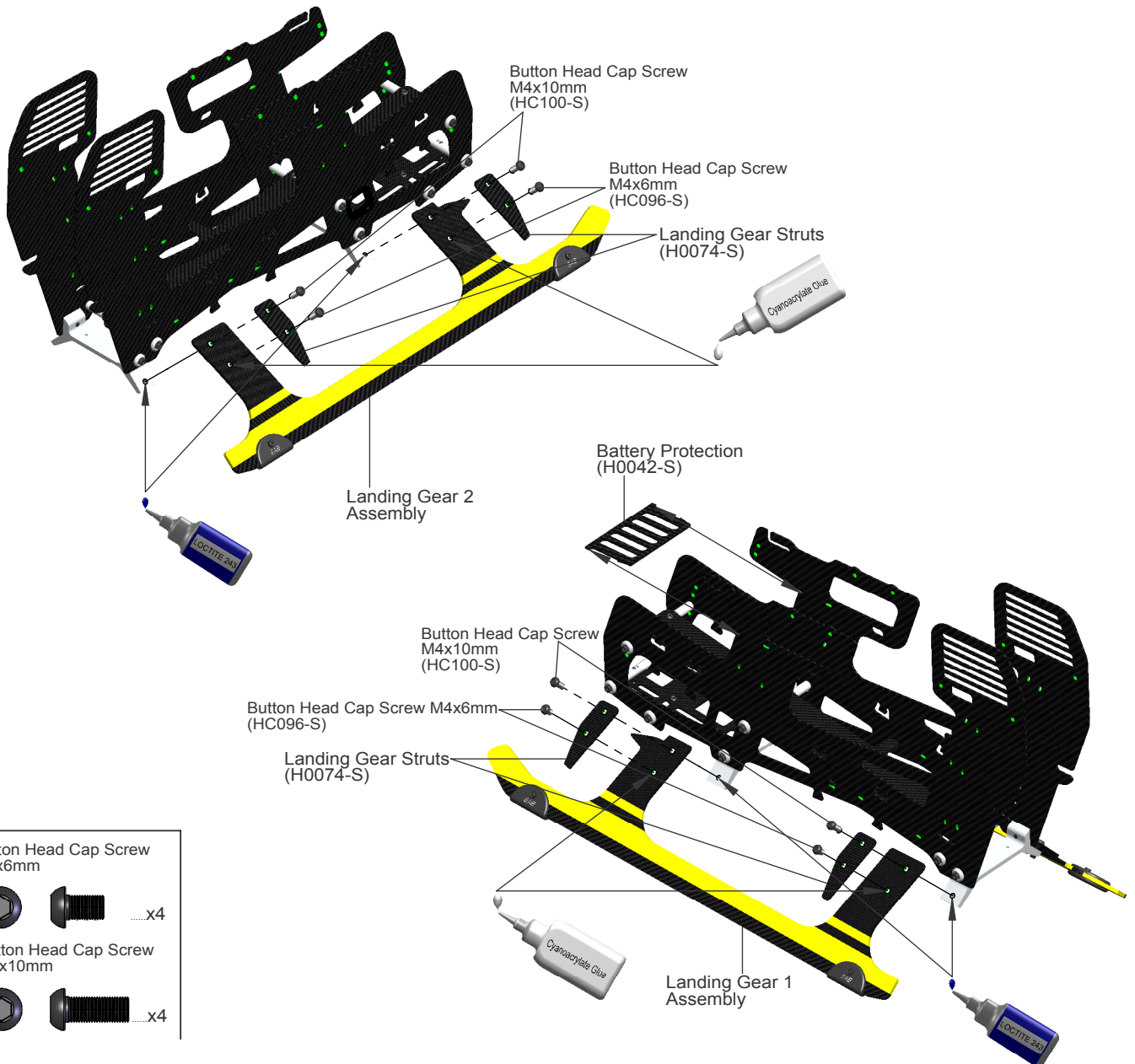

Button Head Cap Screw M4x6mm



Button Head Cap Screw M4x10mm





5 - Transmission Assembly

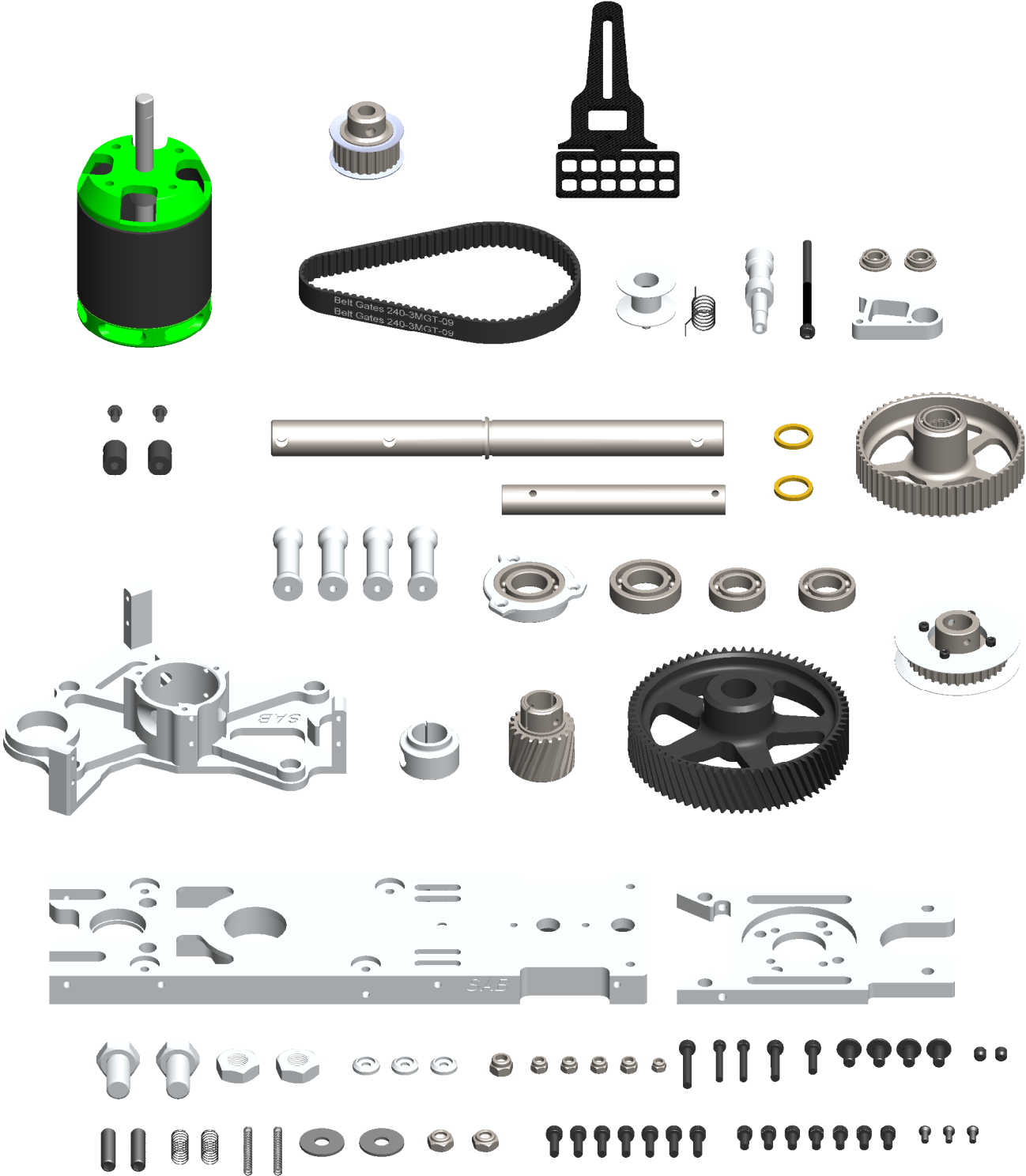



SAB HELI DIVISION

**Bag 3
Tray 3-4**

Bearing $\phi 10x\phi 19x5mm$

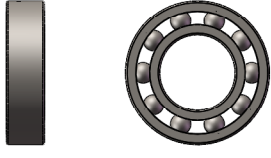

...x1

Bearing $\phi 12x\phi 24x6mm$

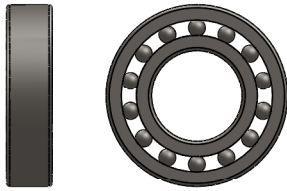

...x1

Socket Head Cap Screw M3x10mm



...x4

Flat Head Cap Screw M2.5x5mm



...x3

Bearing $\phi 12x\phi 24x6mm$ (HC426-S)

Bearing Support Assembly (H0024-S)

Already assembled by Factory.

Socket Head Cap Screw M3x10mm (HC056-S)

Servo Support (H0010-S)

Flat Head Cap Screw M2.5x5mm (HC128-S)

Socket Head Cap Screw M3x10mm (HC056-S)

Column (H0018-S)

Bearing $\phi 10x\phi 19x5mm$ (HC422-S)

Already assembled by Factory.

**Box 6
Bag 3
Tray 4**

Note:

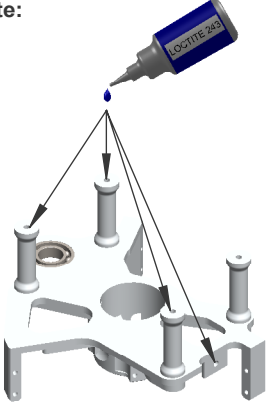

Already assembled by Factory.

Bearing $\phi 12x\phi 24x6mm$

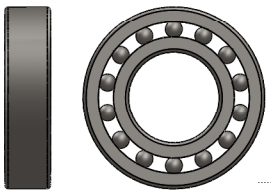

...x1

Bearing $\phi 10x\phi 19x5mm$

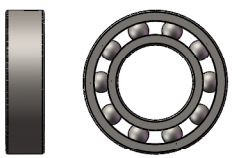

...x1

Socket Head Cap Screw M3x10mm



...x3

Socket Head Cap Screw M3x8mm



...x1

Button Head Cap Screw M3x4mm



...x2

Bearing $\phi 10x\phi 19x5mm$ (HC422-S)

Main Structure (H0009-S)

Swash plate Anti-Rotation Guide (H0017-S)

Finishing Washer M3 (H0007-S)

Socket Head Cap Screw M3x8mm (HC050-S)

Bearing $\phi 12x\phi 24x6mm$ (HC426-S)

Already assembled by Factory.

Antenna Guide (H0050-S)

Button Head Cap Screw M3x4mm (HC038-S)

SAB HELI DIVISION



**Bag 4
Tray 1**

Note 1: When you tighten the collar (H0121-S) on the main shaft, ensure there is no axial play. Push down the main shaft while pulling up the locking collar. Tighten the screw M4x22 at this time.

Note 2:

The pinion and gear are designed to have zero backlash. This leads to initial "rough" rotation. After some run in flights (3-5 flights) it will begin to rotate freely, ensuring perfect contact and the ability to transmit maximum power. It is advisable to lubricate these two elements with a lubricant (eg Silicone or Tri-Flow Synthetic grease).

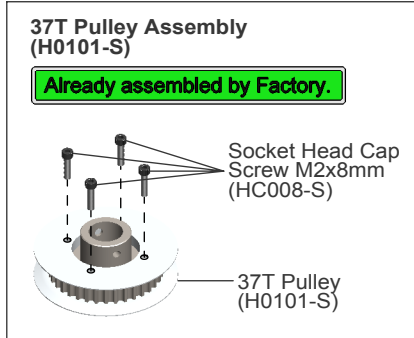
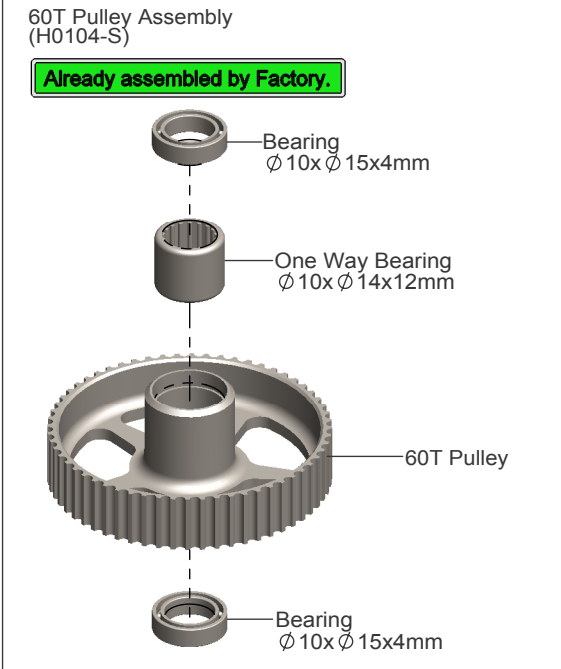
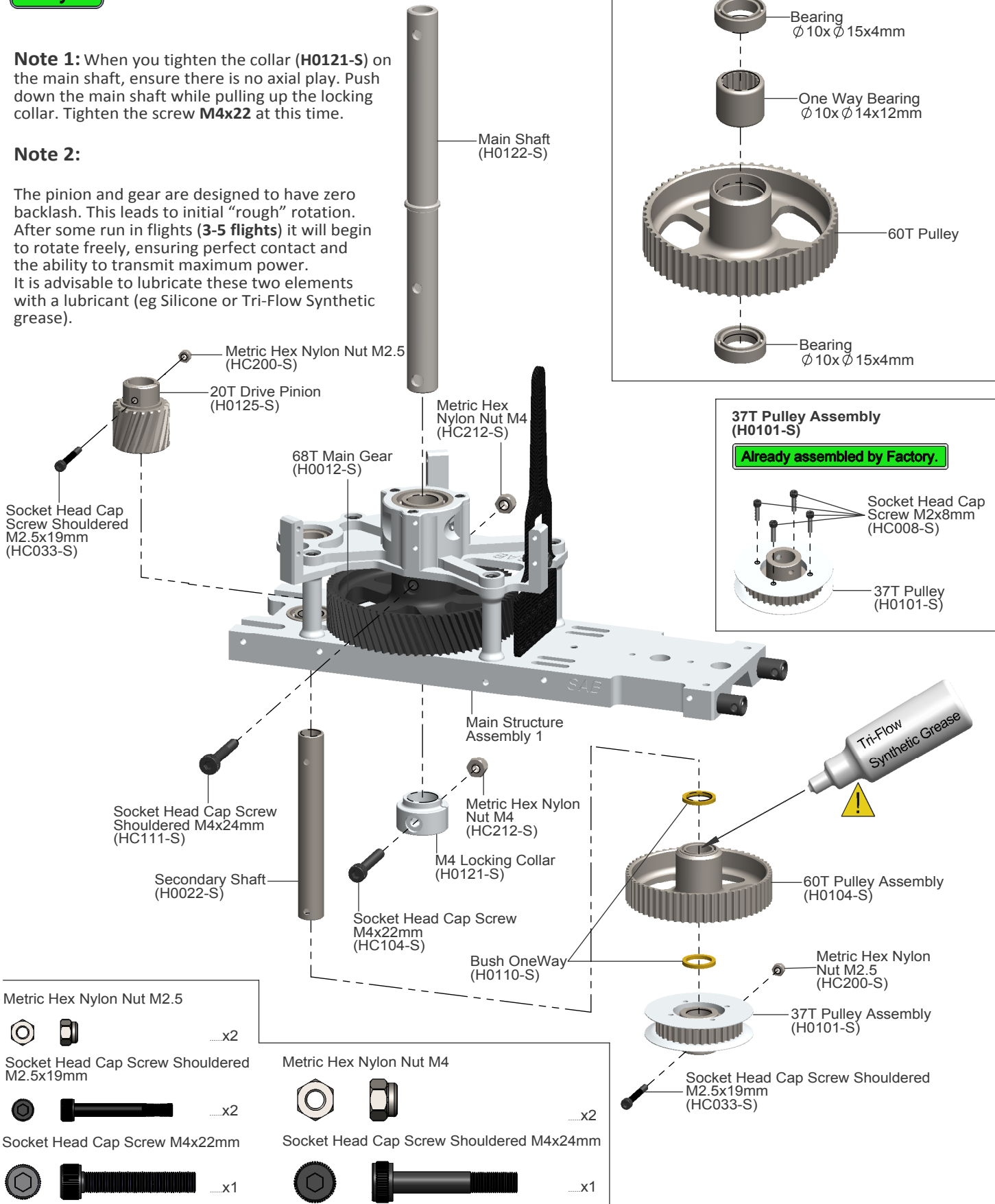

Metric Hex Nylon Nut M2.5



Socket Head Cap Screw Shouldered M2.5x19mm



Socket Head Cap Screw M4x22mm



Metric Hex Nylon Nut M4



Socket Head Cap Screw Shouldered M4x24mm





**Bag 5
Tray 4**

Tail Belt Idler Assembly (H0070-S)

Already assembled by Factory.

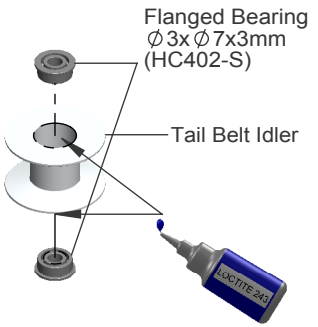

Belt Tensioner Arm Assembly (H0070-S)

Already assembled by Factory.

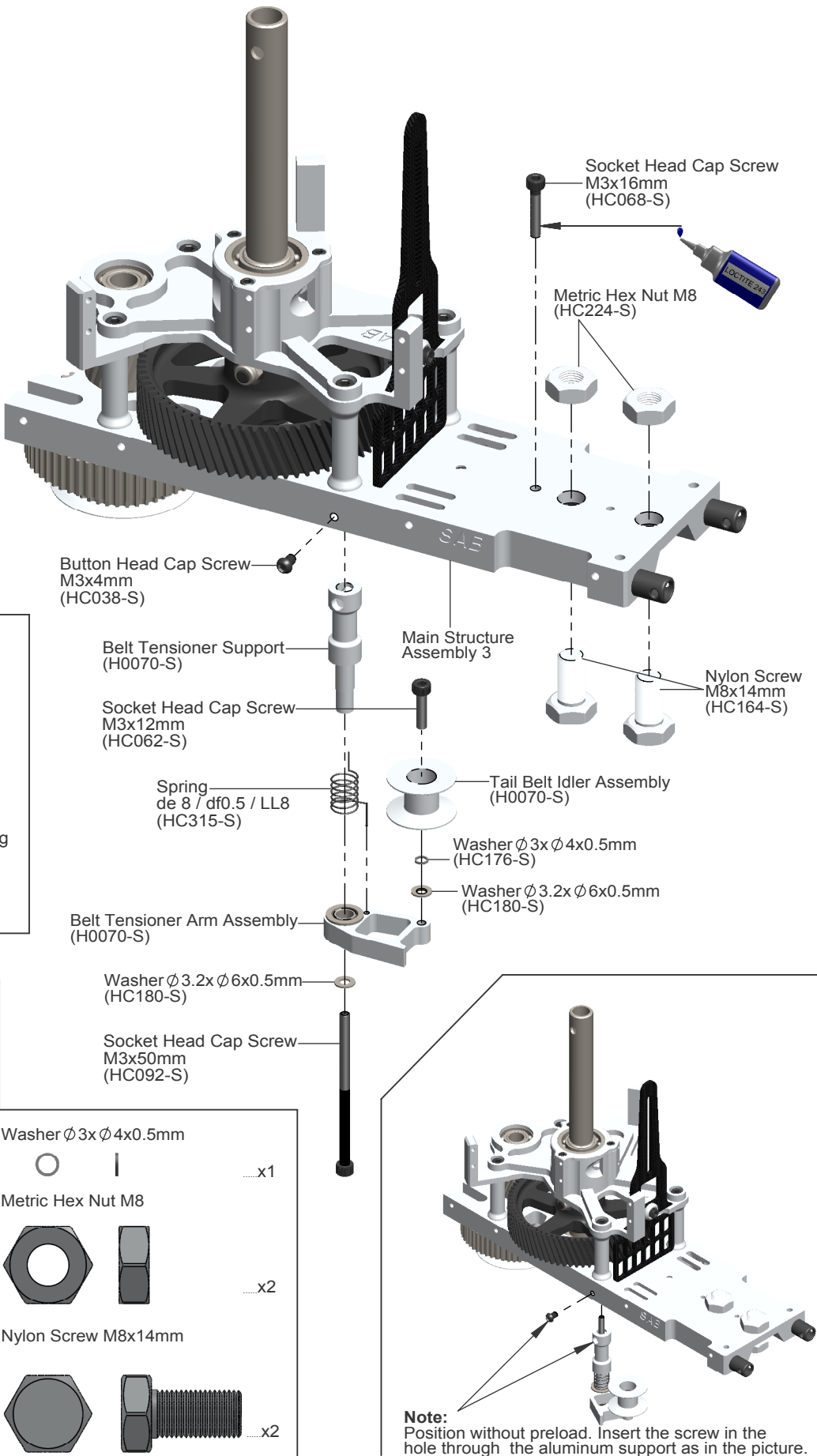
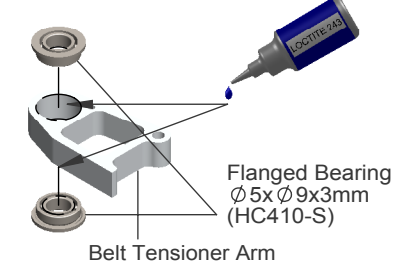

Note: Position without preload. Insert the screw in the hole through the aluminum support as in the picture.

Button Head Cap Screw M3x4mm



Socket Head Cap Screw M3x12mm



Socket Head Cap Screw M3x50mm



Flanged Bearing $\phi 5x \phi 9x3mm$



Flanged Bearing $\phi 3x \phi 7x3mm$



Washer $\phi 3x \phi 4x0.5mm$



Metric Hex Nut M8

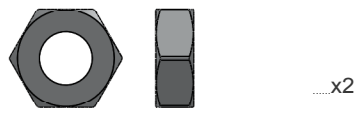

Nylon Screw M8x14mm

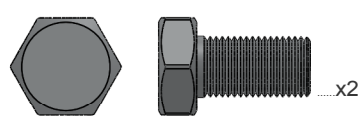





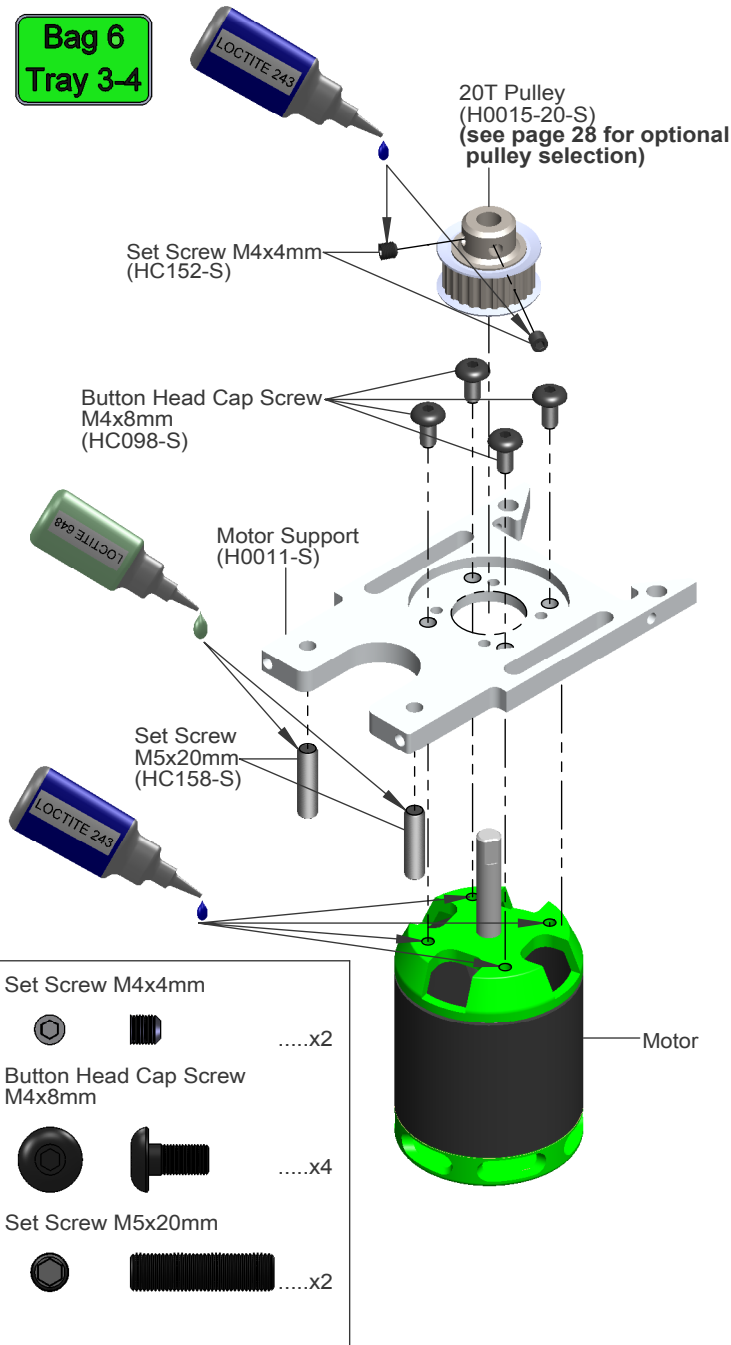



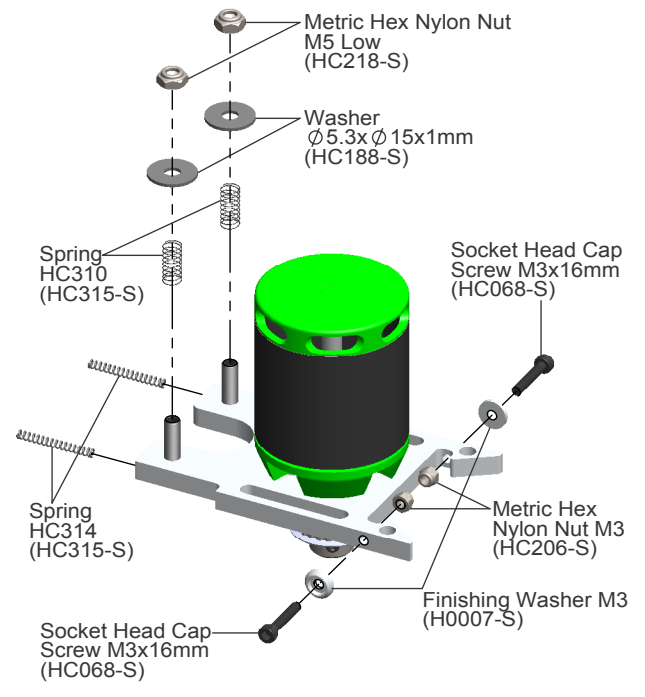

Bag 6
Tray 3-4



- Set Screw M4x4mm
 x2
- Button Head Cap Screw M4x8mm
 x4
- Set Screw M5x20mm
 x2

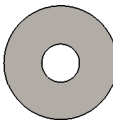

- Metric Hex Nylon Nut M3
 x2
- Finishing Washer M3
 x2
- Socket Head Cap Screw M3x16mm
 x2
- Washer Ø5.3xØ15x1mm
 x2

Note:

To maximize space for the batteries, it is advisable to shorten the motor shaft. Follow the dimensions given in this drawing. For the cut, you can use an electric tool like a "Dremel" with a cut-off disc. Additionally, ensure the motor shaft has an appropriate 'flat' for one of the set screws.

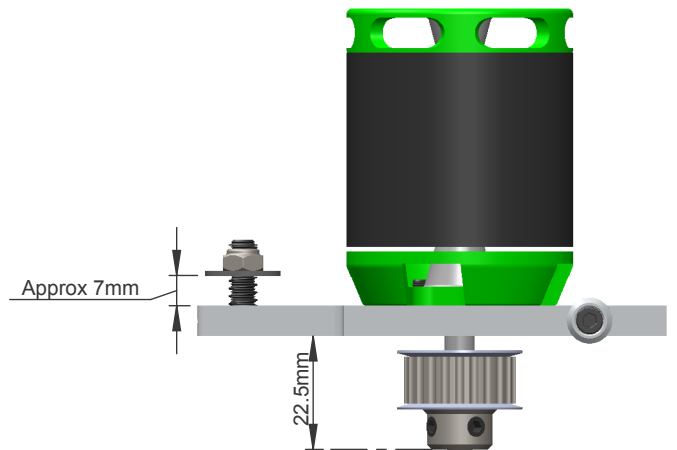
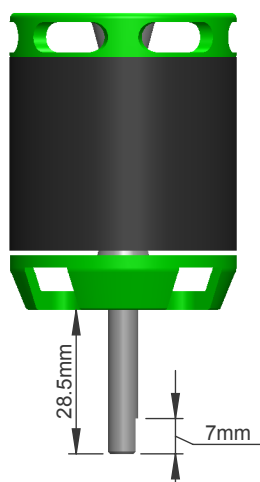



6 - Main Rotor

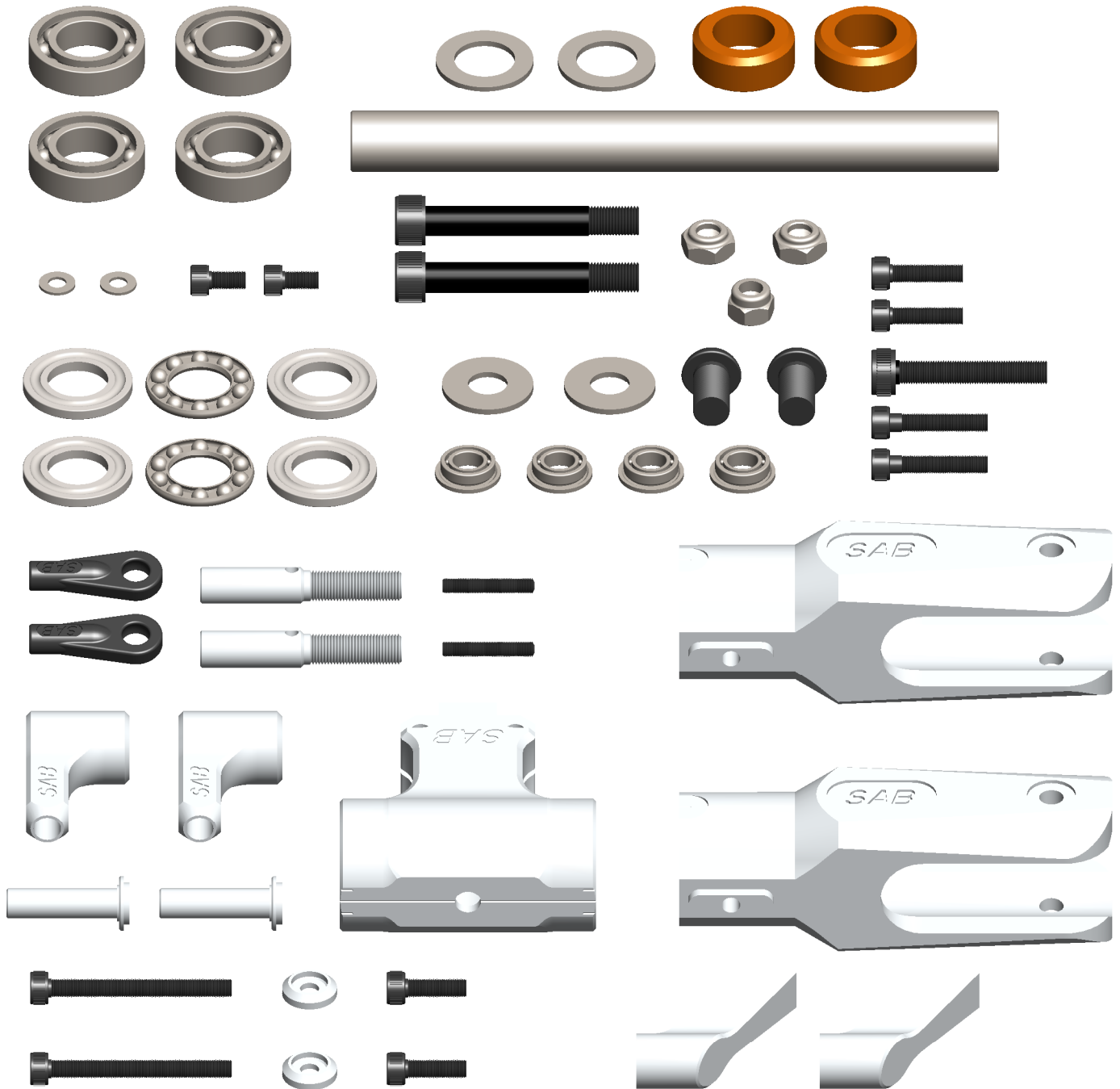



SAB HELI DIVISION

Tray 1

Blade Grip Arm Assembly x 2

Already assembled by Factory.

Main Linkage Assembly

Main Linkage (H0033-S)

Set Screw M2.5x15mm (HC146-S)

2mm

Note: HC146 must be strongly blocked with HC0033.

Main Linkage Assembly

Plastic Ball Linkage (H0066-S)

Blade Grip Arm (H0032-S)

Center Blade Grip Arm (H0085-S)

Flanged Bearing $\phi 5x\phi 9x3mm$ (HC410-S)

Tri-Flow Synthetic Grease

Flanged Bearing $\phi 5x\phi 9x3mm$

Set Screw M2.5x15mm

x4

x2

Note:

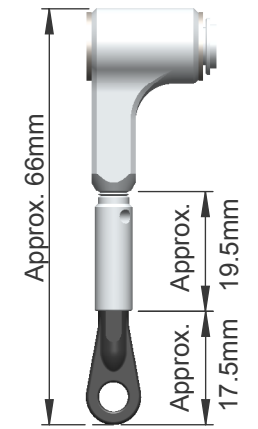

Bag 7 Tray 1

Already assembled by Factory.

Damper Hard (H0027-S)

Spindle (H0097-S)

Center Hub (H0026-S)

Socket Head Cap Screw M3x30mm (HC090-S)

Finishing Washer M3 (H0007-S)

Washer 10x16x1mm (HC230-S)

Blade Grip Arm Assembly

Washer $\phi 10x\phi 16x0.2mm$ (HC232-S)

Main Blade Grip Assembly

Thrust Bearing $\phi 10x\phi 18x5.5mm$ (HC438-S)

Washer $\phi 10x\phi 16x1mm$

Washer $\phi 6x\phi 14x1mm$ (HC194-S)

Button Head Cap Screw M6x10mm (HC122-S)

Tri-Flow Synthetic Grease

Chamfer on the outside.

Main Blade Grip Assemblyx2

Main Blade Grip (H0086-S)

Blade Grip Arm (H0087-S)

Socket Head Cap Screw M3x10mm (HC056-S)

Bearing $\phi 10x\phi 19x5mm$ (HC422-S)

Already assembled by Factory.

Swashplate Assembly

Uniball M3x4 $\phi 5H3$ (H065-S)

Uniball M3x4 $\phi 5H18$ (H063-S)

Swashplate Assembly (H023-S)

Uniball M3x4 $\phi 5H3$ (H065-S)

Already assembled by Factory.

Note: Larger ID

Note: Smaller ID

Finishing Washer M3 x2

Button Head Cap Screw M6x10mm x2

Socket Head Cap Screw M3x30mm x2

Thrust Bearing $\phi 10x\phi 18x5.5mm$ (HC438-S)

Washer $\phi 10x\phi 16x1mm$

Washer $\phi 10x\phi 16x1mm$

Washer $\phi 6x\phi 14x1mm$ (HC194-S)

Bearing $\phi 10x\phi 19x5mm$ (HC422-S)



7-Boom and Tail

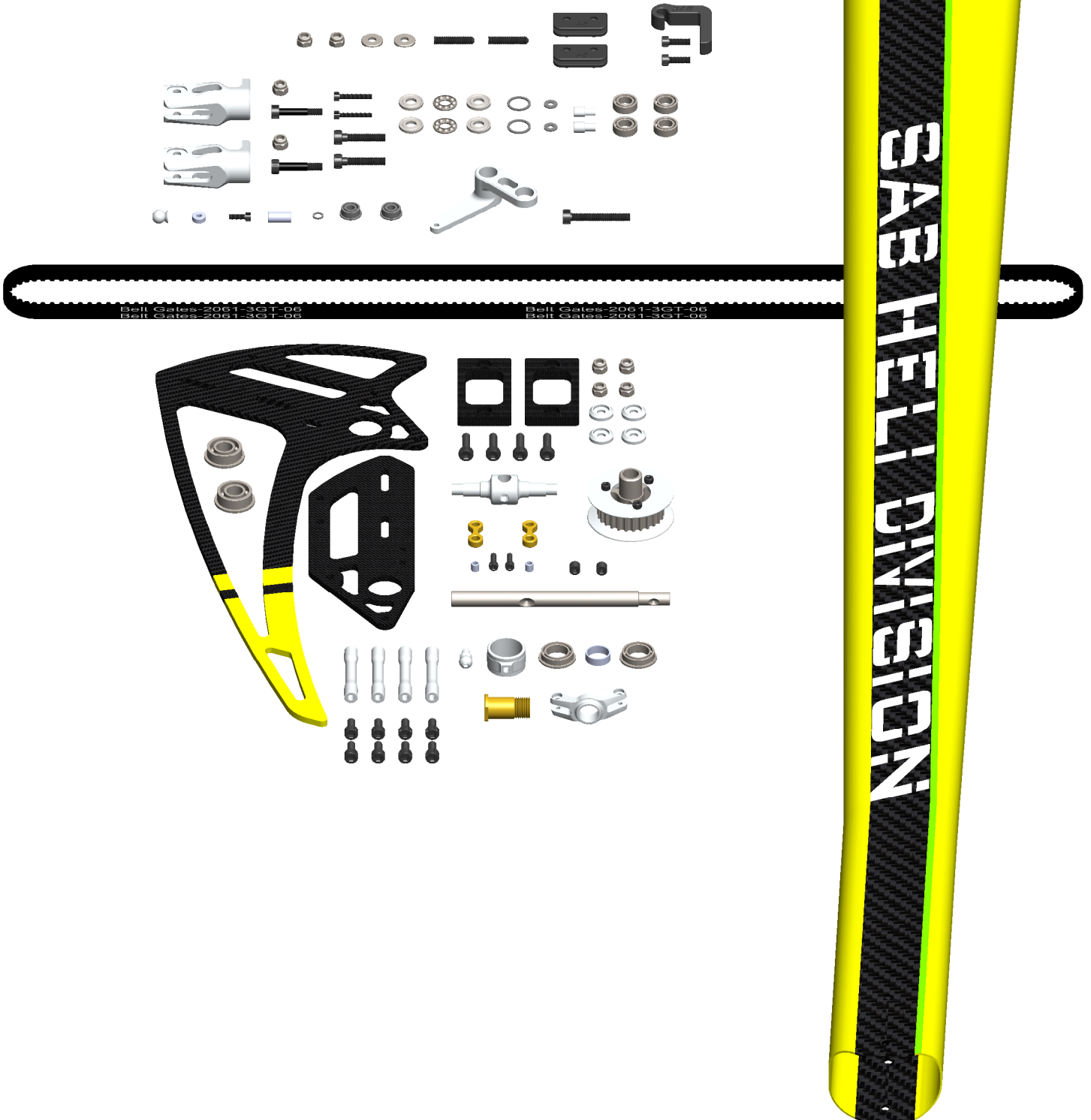



Tail Blade Grip Assembly x 2
(H0052-S)

Already assembled by Factory.

Bearing $\varnothing 5 \times \varnothing 9 \times 3 \text{mm}$



...x4

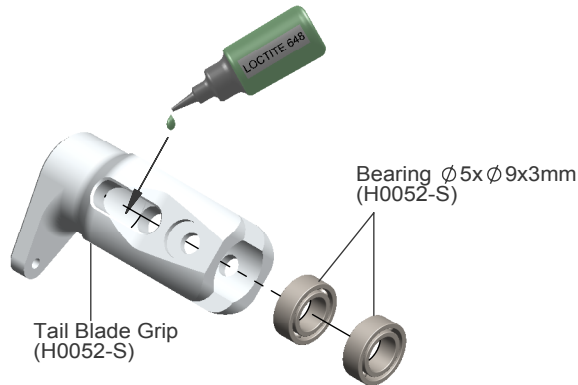

Bag 8
Tray 2

Washer $\varnothing 3 \times \varnothing 4 \times 0.5 \text{mm}$



...x1

Socket Head Cap Screw
M2x8mm



...x1

Socket Head Cap Screw
M3x22mm



...x1

Flanged Bearing $\varnothing 3 \times \varnothing 7 \times 3 \text{mm}$



...x2

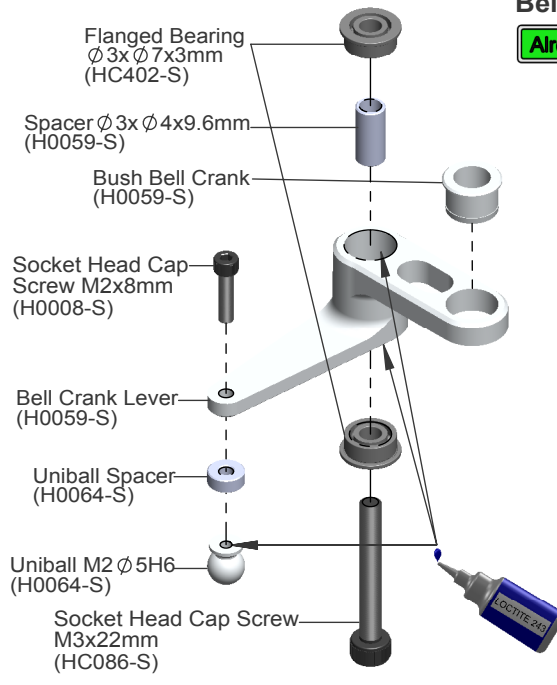

Bell Crank Lever Assembly

Already assembled by Factory.

Bell Crank Base
(H0058-S)

Washer
 $\varnothing 3 \times \varnothing 4 \times 0.5 \text{mm}$

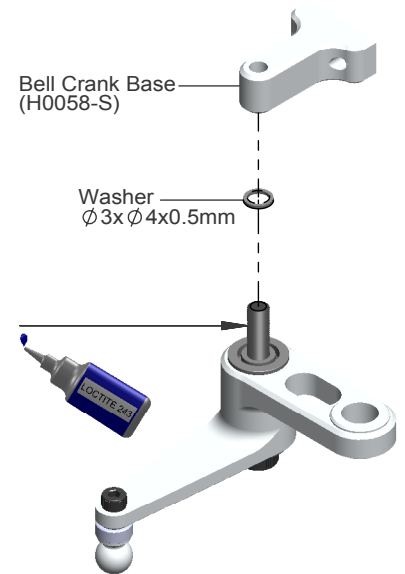

Tray 2

Tail Pitch Slider Assembly

Already assembled by Factory.

Tail Pitch Slider 01
(H0053-S)

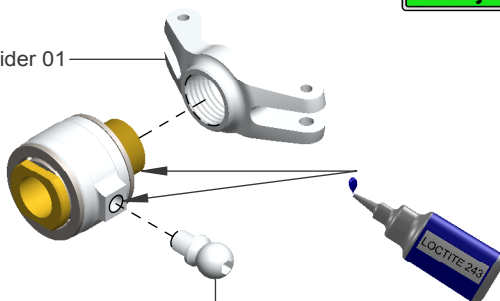

Uniball M3x3.5 $\varnothing 5 \text{H3}$
(H0065-S)

Flanged Bearing $\varnothing 8 \times \varnothing 12 \times 3.5 \text{mm}$

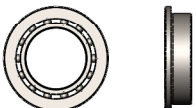

...x2

Flanged Bearing
 $\varnothing 8 \times \varnothing 12 \times 3.5 \text{mm}$
(HC418-S)

Spacer
 $\varnothing 8.1 \times \varnothing 9.2 \times 3.2 \text{mm}$

Tail Pitch Slider 02
(H0053-S)

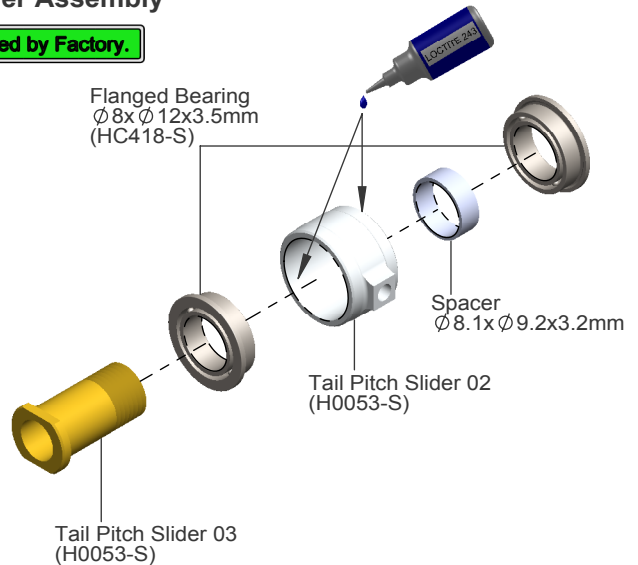



Tray 2 Tail Pitch Slider Link Assembly

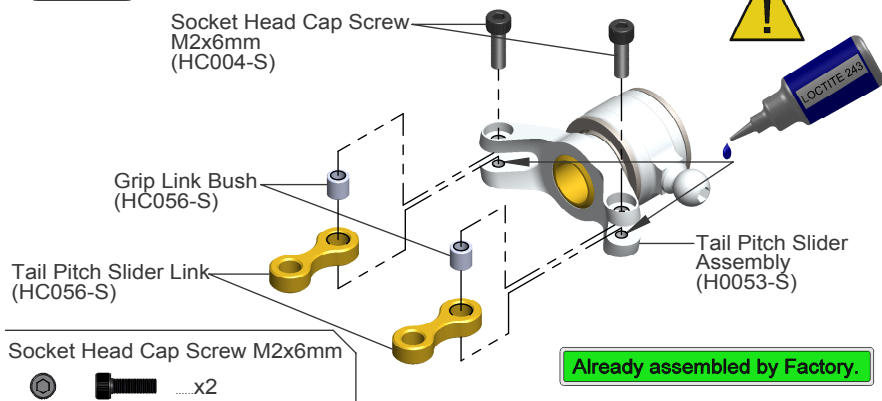

Tray 2 **Already assembled by Factory.**

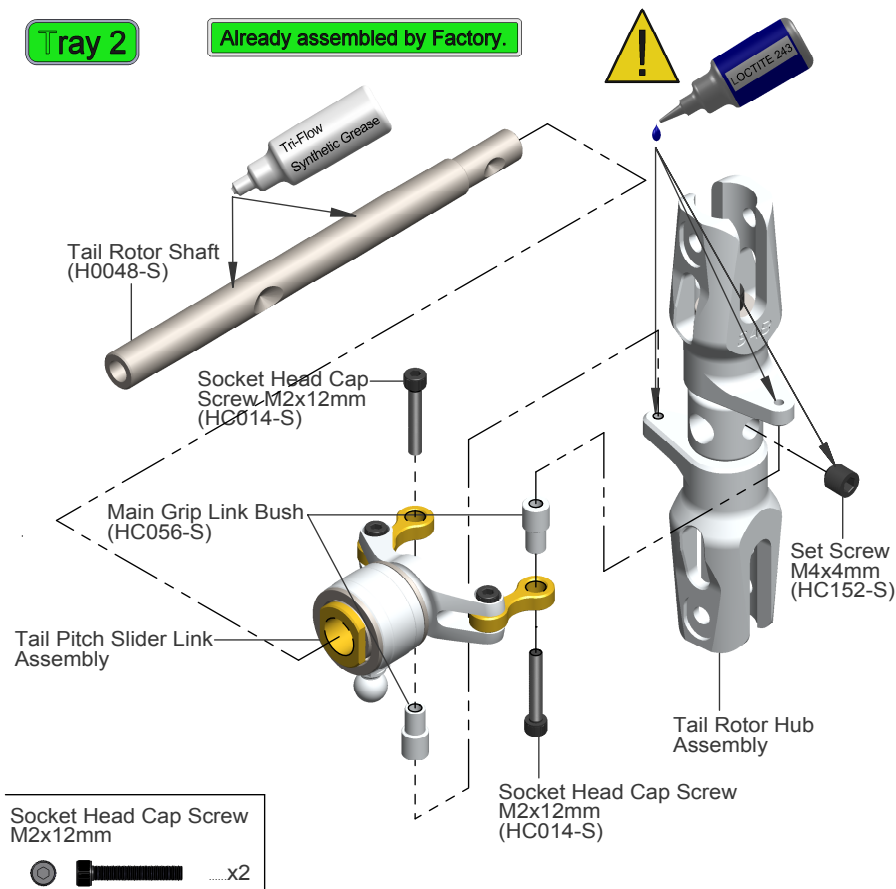

- Socket Head Cap Screw M3x16mm
- Spacer $\varnothing 7 \times \varnothing 9 \times 5 \text{mm}$
- Thrust Bearing $\varnothing 4 \times \varnothing 9 \times 4 \text{mm}$

Tray 2 Tail Rotor Hub Assembly

Already assembled by Factory.

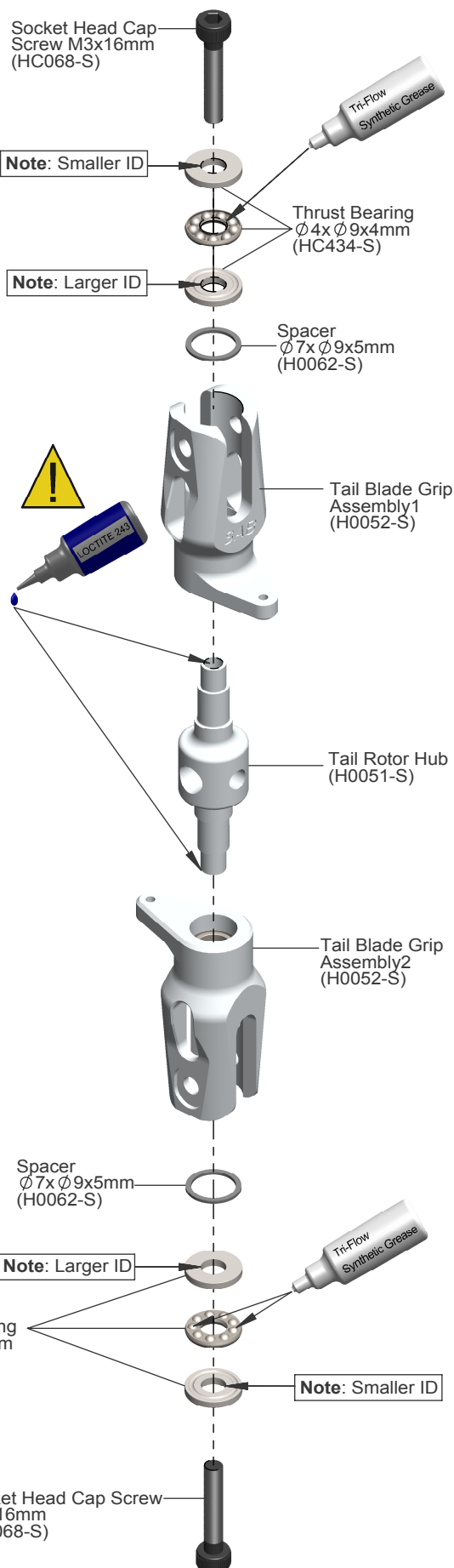



Bag 6

Vertical Fin Assembly

Already assembled by Factory.

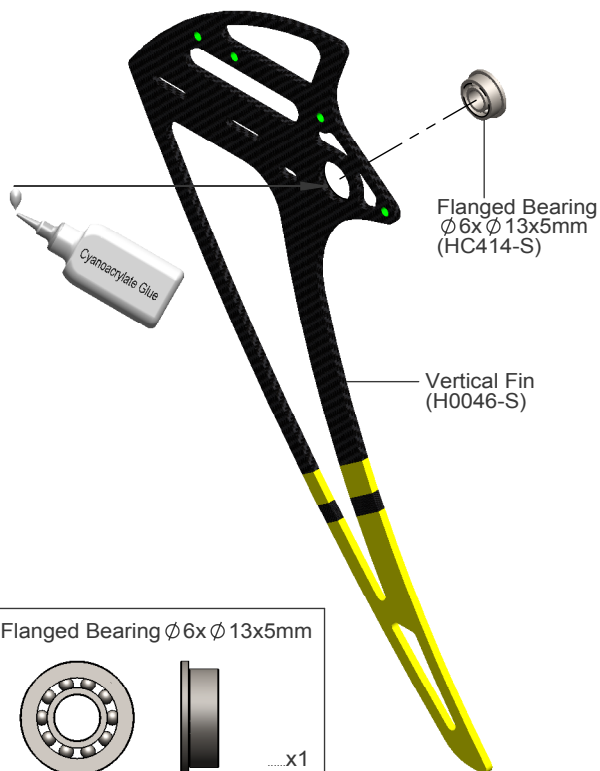

Flanged Bearing $\varnothing 6 \times \varnothing 13 \times 5 \text{mm}$

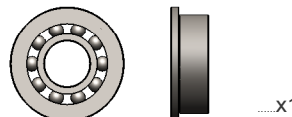

Box 6
Bag 9
Tray 2

Tail Side Plate Assembly

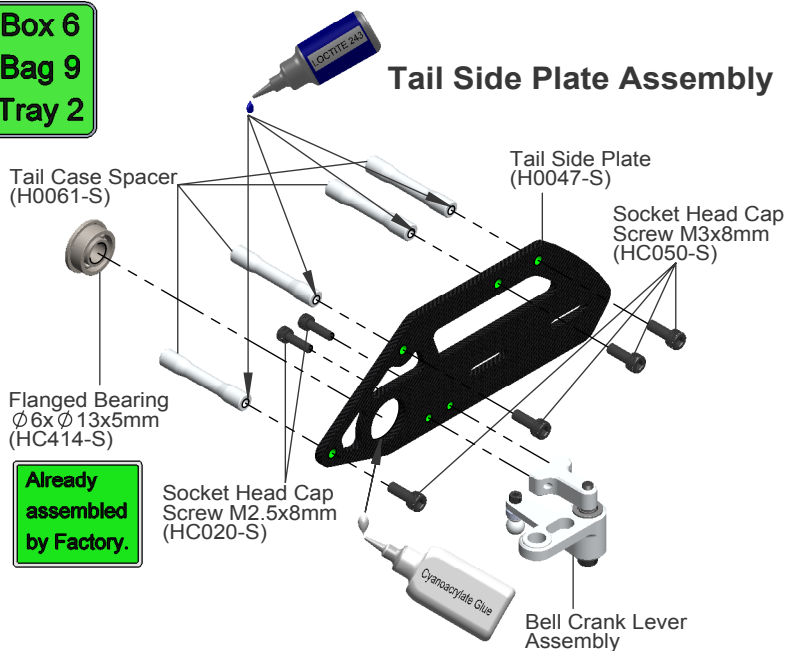

Tail Case Spacer (H0061-S)

Tail Side Plate (H0047-S)

Socket Head Cap Screw M3x8mm (HC050-S)

Flanged Bearing $\varnothing 6 \times \varnothing 13 \times 5 \text{mm}$ (HC414-S)

Socket Head Cap Screw M2.5x8mm (HC020-S)

Bell Crank Lever Assembly

Already assembled by Factory.

Flanged Bearing $\varnothing 6 \times \varnothing 13 \times 5 \text{mm}$ Socket Head Cap Screw M2.5x8mm

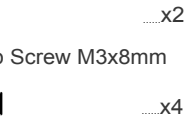
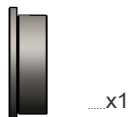
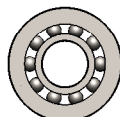

Bag 9
Tray 2

Tail System Assembly

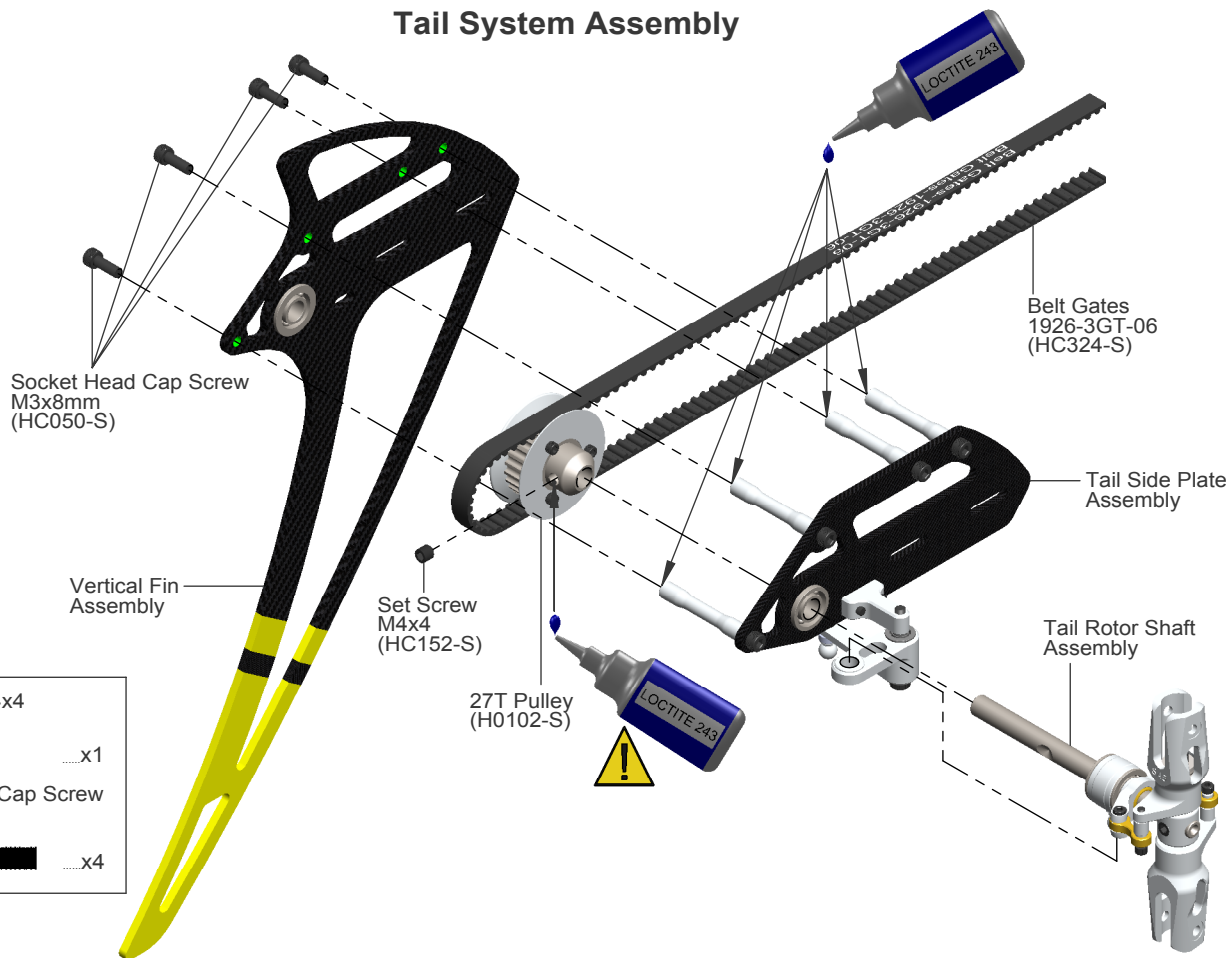

Socket Head Cap Screw M3x8mm (HC050-S)

Vertical Fin Assembly

Set Screw M4x4 (HC152-S)

27T Pulley (H0102-S)

Belt Gates 1926-3GT-06 (HC324-S)

Tail Side Plate Assembly

Tail Rotor Shaft Assembly



- Set Screw M4x4 ...x1
- Socket Head Cap Screw M3x8mm ...x4



Box 3
Bag 10

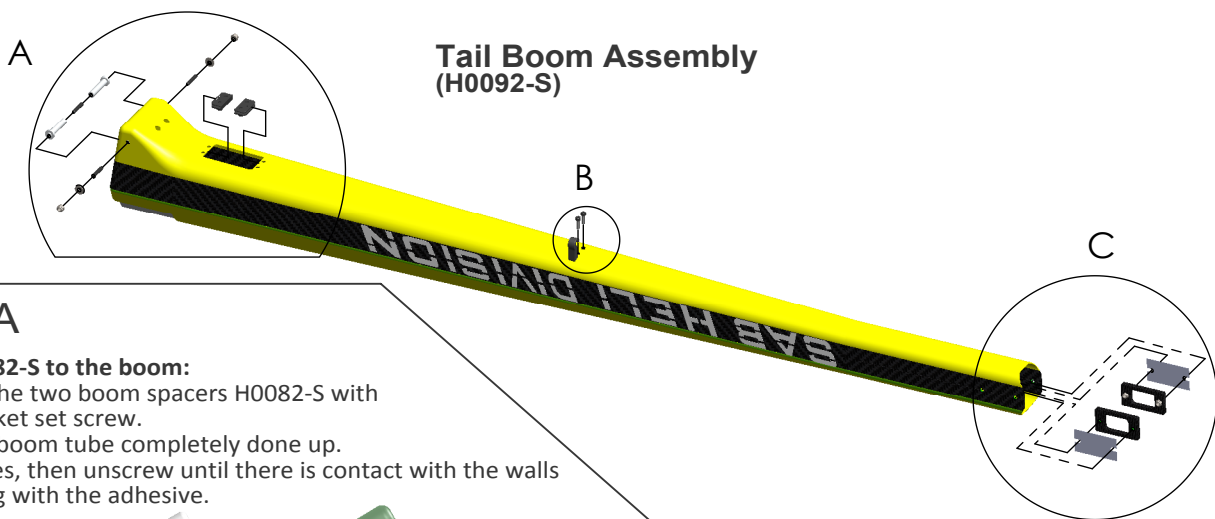

Tail Boom Assembly (H0092-S)

DETAIL A

Attaching H0082-S to the boom:

Pre-assemble the two boom spacers H0082-S with the M3x20 socket set screw. Insert into the boom tube completely done up. Center the holes, then unscrew until there is contact with the walls. Lock everything with the adhesive.

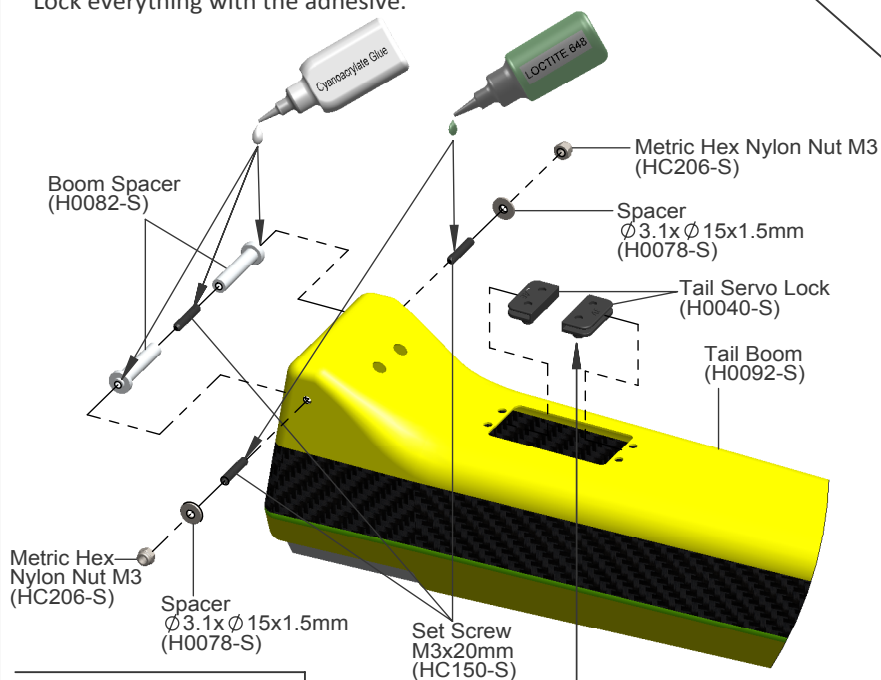

- Set Screw M3x20mm
● ————— x3
- Metric Hex Nylon Nut M3
⊕ ⊞ x2

Assemble H0040-S in the boom

Before assembling the two parts in the boom we suggest tightening the M2.5 screws into the two plastic parts to pre-thread them. In this way when you will assemble the tail servo it will be easier to tighten the screws into the plastic parts. Check the tail servo can fit, if necessary carefully sand the hole.

DETAIL B

Assemble H0045-S in the boom

Before mounting H0045 on the boom we suggest to first tighten the M2.5 screws into the holes to thread them. In this way when you assemble the part it will be easier to tighten the screws.

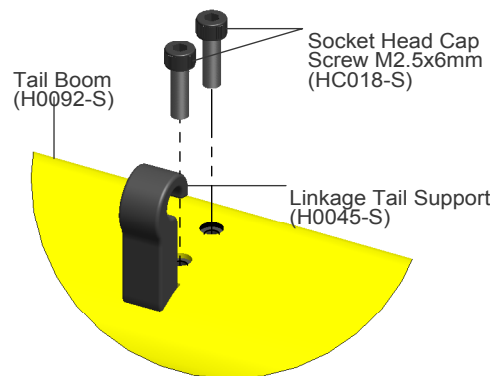

- Socket Head Cap Screw M2.5x6mm
⊕ ————— x2

Locking Element Tail Assembly X 2

Already assembled by Factory.

- Locking Element Tail H0041
- Metric Hex Nylon Nut M3 (HC206-S)

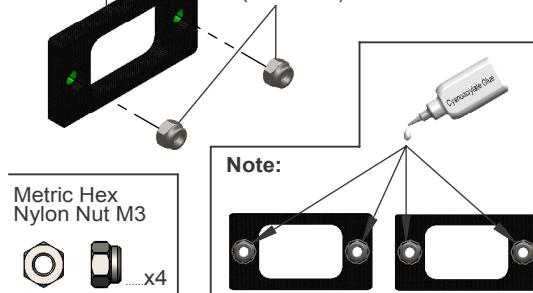

- Metric Hex Nylon Nut M3
⊕ ⊞ x4

Note:



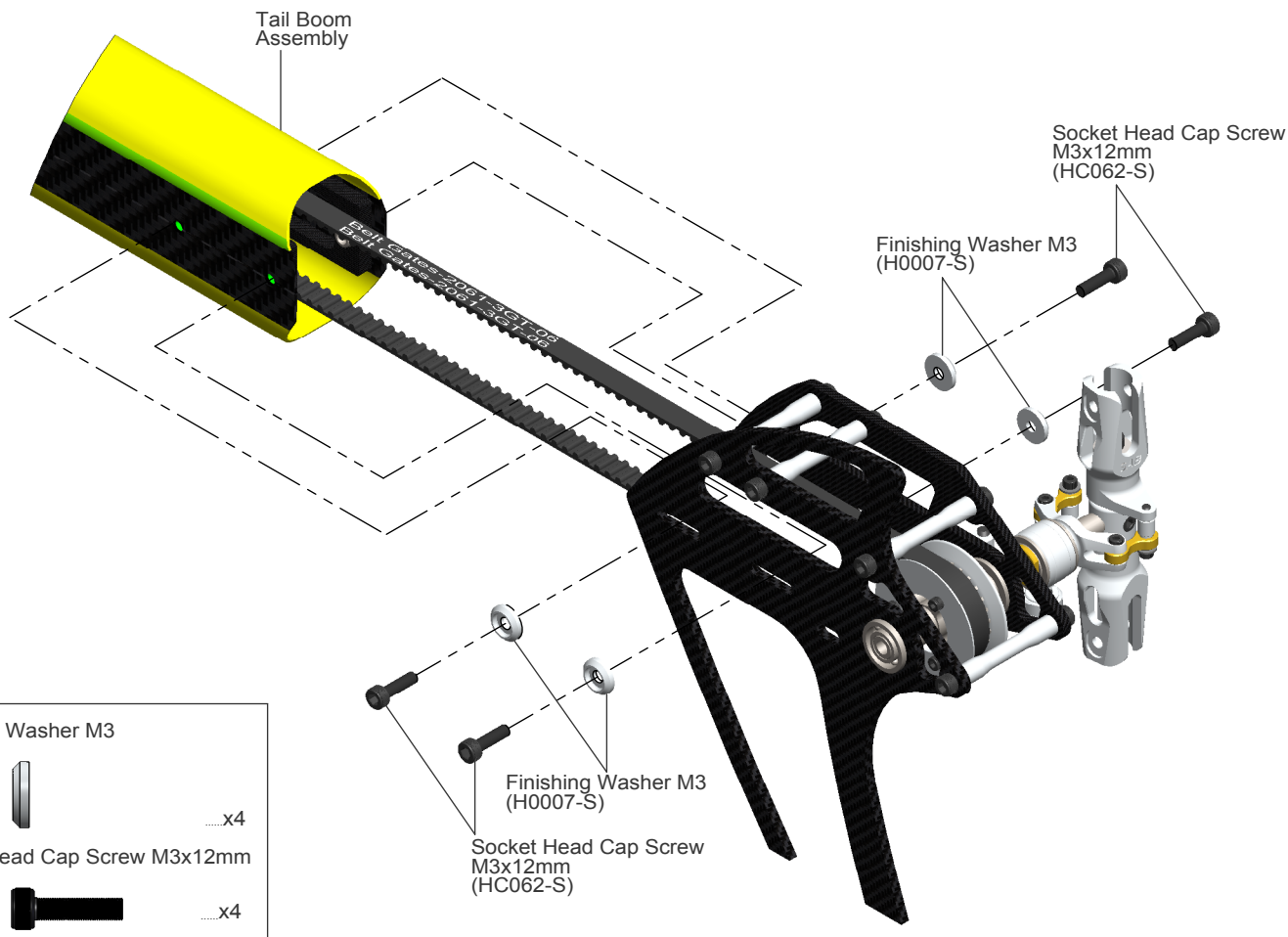

- | | |
|-------------------------------|---------|
| Finishing Washer M3 |x4 |
| Socket Head Cap Screw M3x12mm |x4 |

Box 3
Bag 11

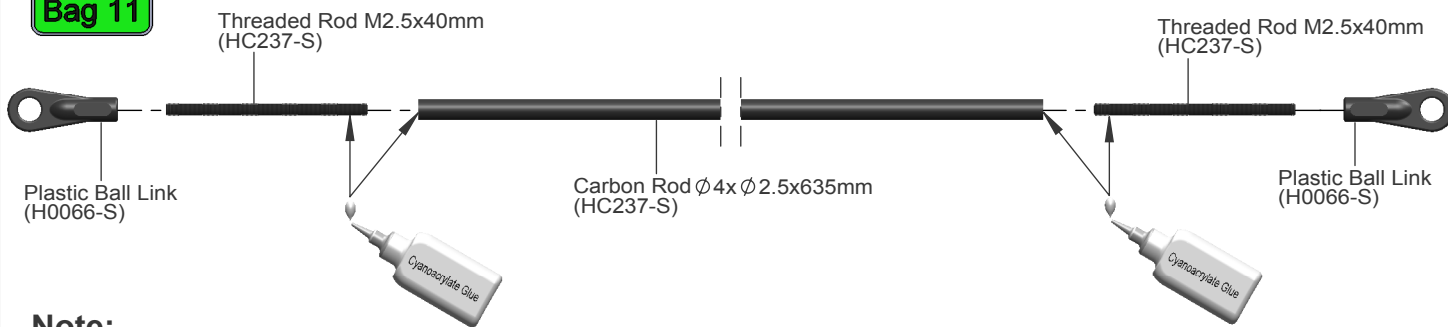

Note:

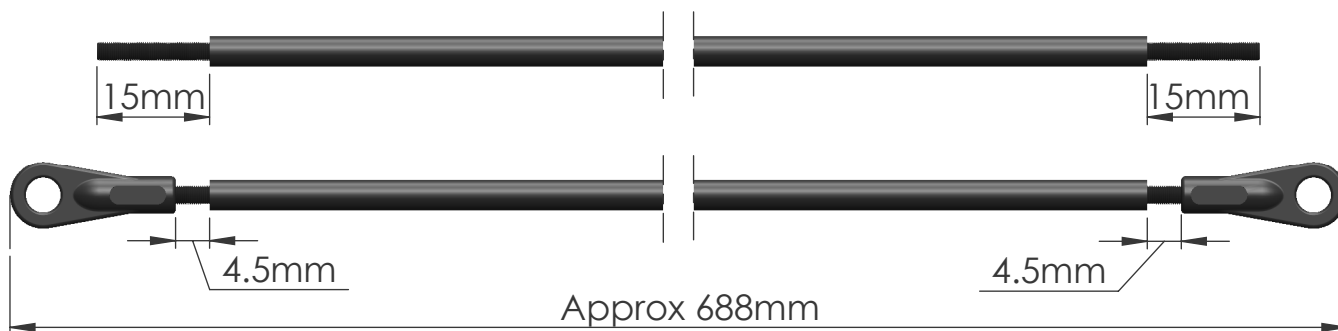



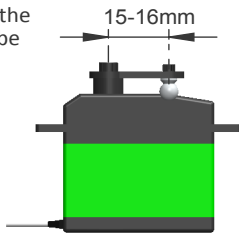

Bag 13

The distance between the axis and the ball must be between 15-16 mm

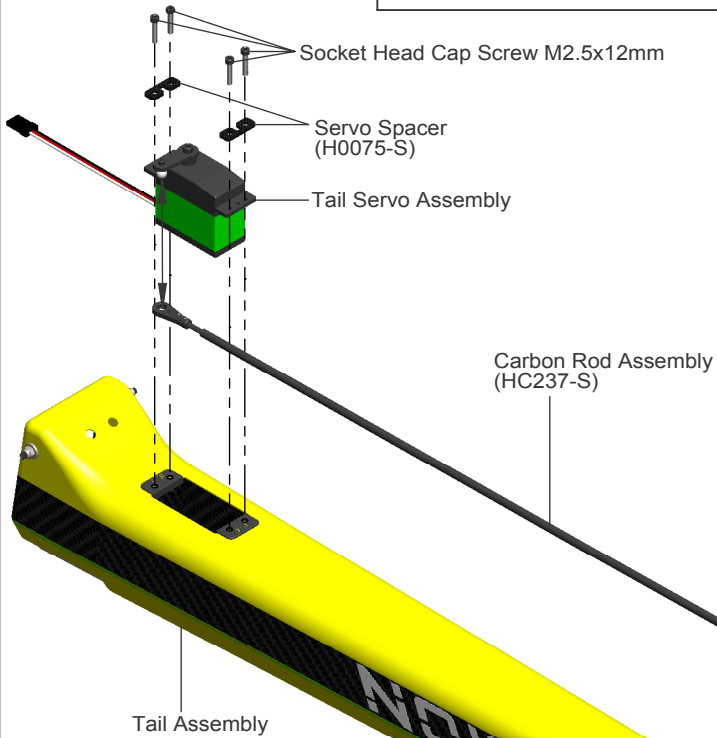
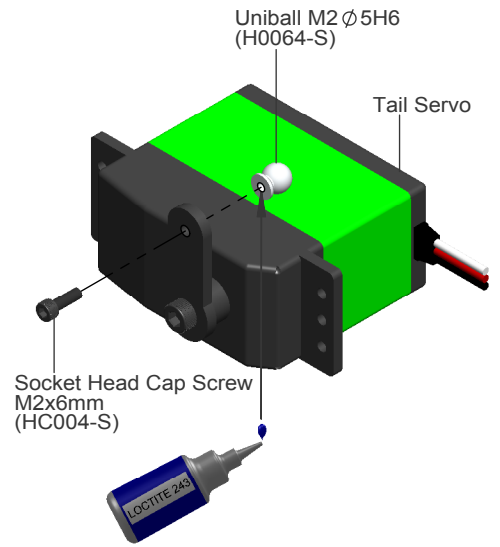

Tail Servo Assembly



- Uniball M2 Ø5H6
 ...x1
- Socket Head Cap Screw M2x6mm
 ...x1
- Socket Head Cap Screw M2.5x12mm
 ...x4

The tail servo wire lead should be secured with hot glue in the area indicated by the arrow (figure 1). Figure 2 shows the installed servo.



Note: Please note that the boom edges might be rough and can eventually chafe or cut your tail servo lead - we recommend protecting the leads with heat shrink or even electrical tape.

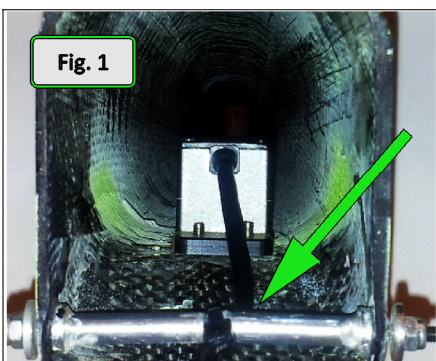

Fig. 1



Fig. 2



**Bag 12
Tray 1**

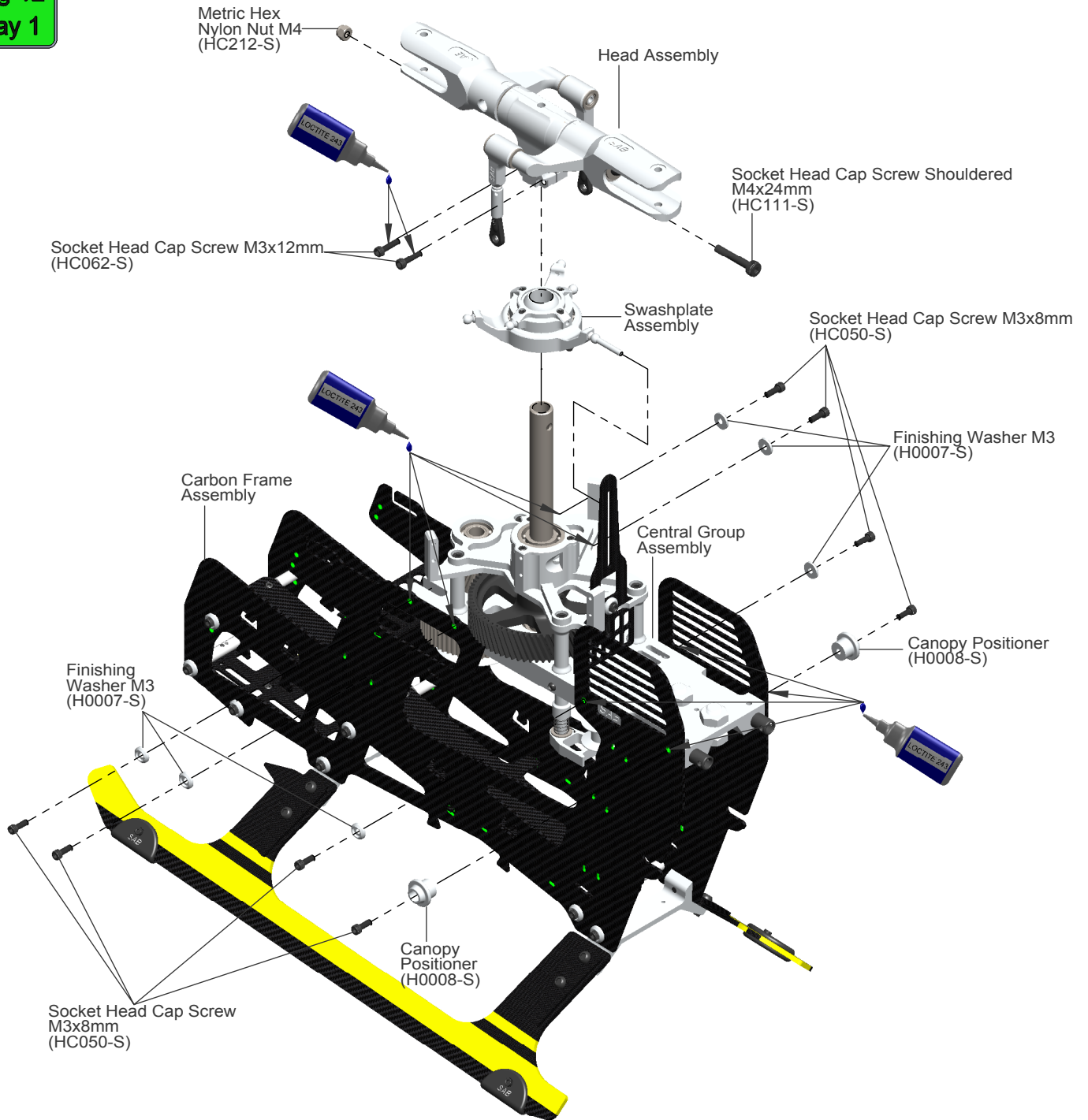

Socket Head Cap Screw M3x8mm



Socket Head Cap Screw M3x12mm



Socket Head Cap Screw Shouldered M4x24mm



Finishing Washer M3



Metric Hex Nylon Nut M4





INSTALLATION OF SWASHPLATE SERVOS

The linkage ball must be positioned between 16-18 mm out on the servo arm (figure 1). The 120° placement of the servos inside Goblin means the arms are difficult to access. For this reason it is advisable to ensure alignment of the servo arms (and sub trim set) before installation of the servos in the model (figure 2). Proceed with installation following the instructions below. Figure 3 shows a completed installation.

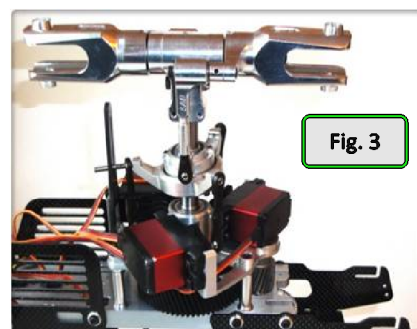
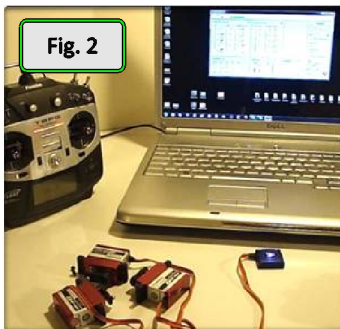
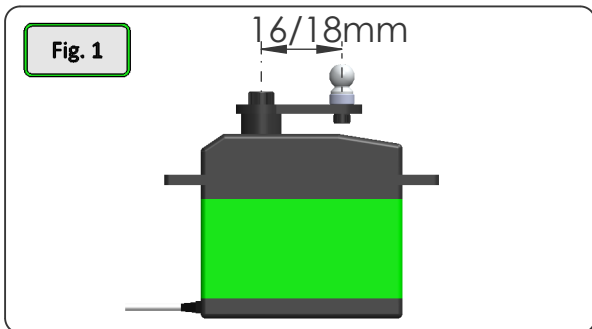

Assembly of the Ball on the Horn.

The rods going from the servos to the swash plate must be as vertical as possible. Not all servos are equal, so to better align them you can choose to use the supplied spacer H0031. Figure 4 illustrates this.

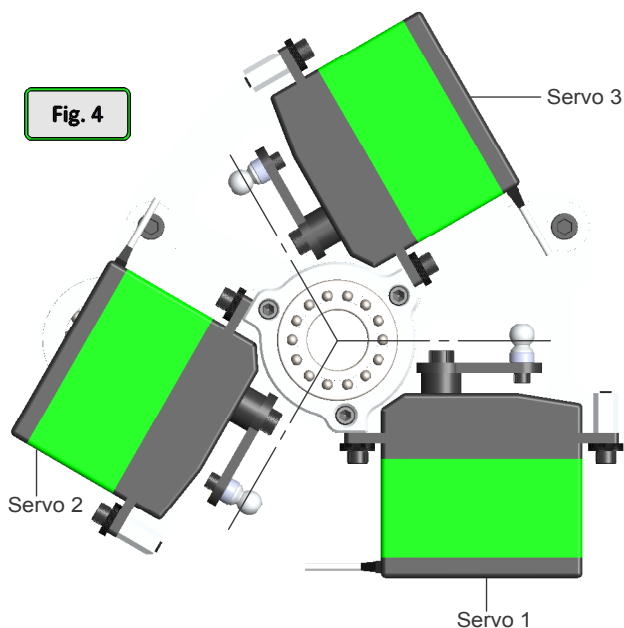

Bag 13

Servos Assembly 1, 2, 3

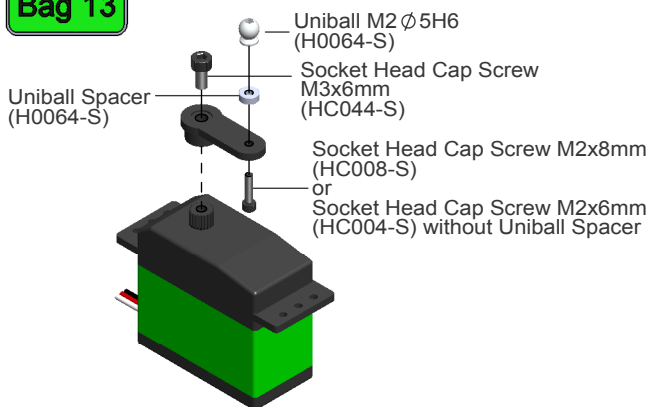

Bag 13

Socket Head Cap Screw M2.5x8mm



Socket Head Cap Screw M2.5x12mm



Socket Head Cap Screw M2.5x8mm (HC020-S)

Socket Head Cap Screw M2.5x12mm (HC026-S)

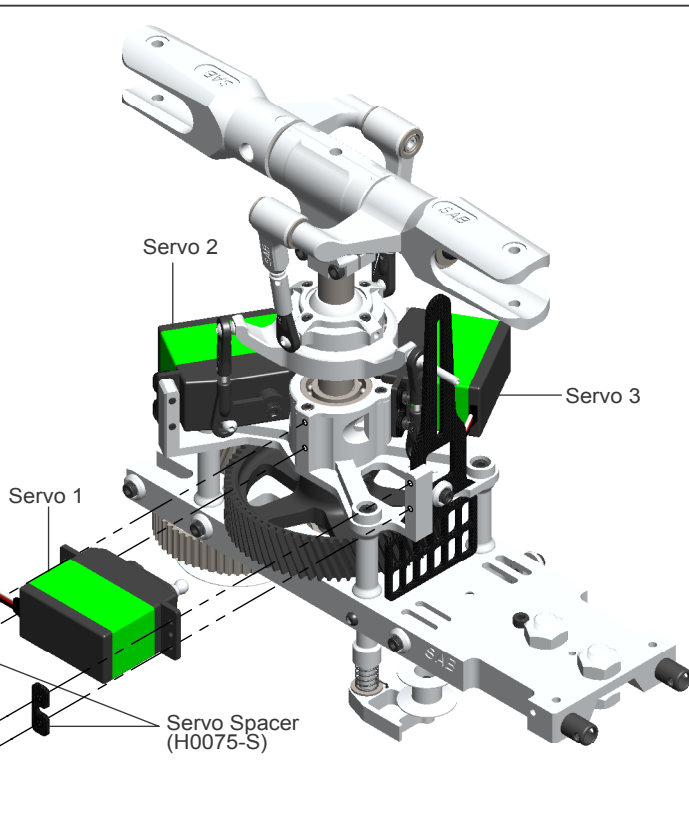



The wire for the front servo must be positioned here.

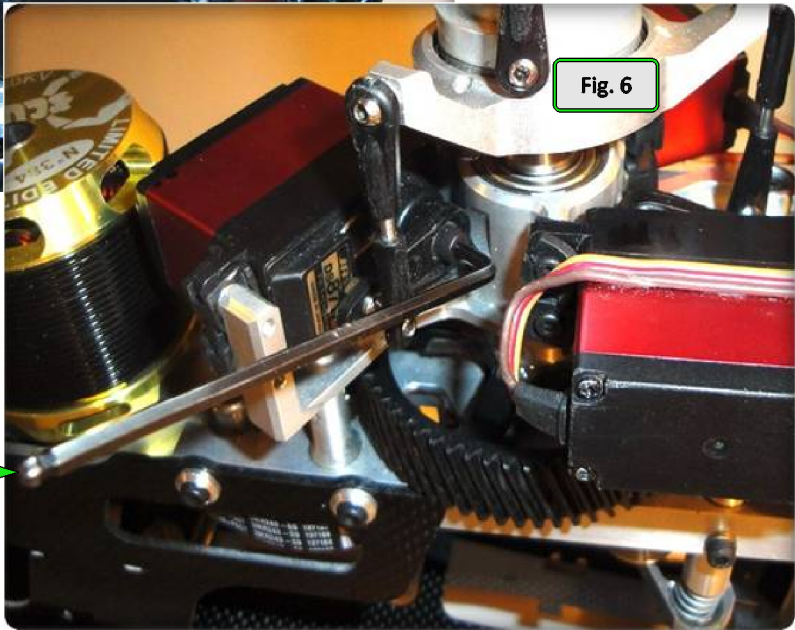
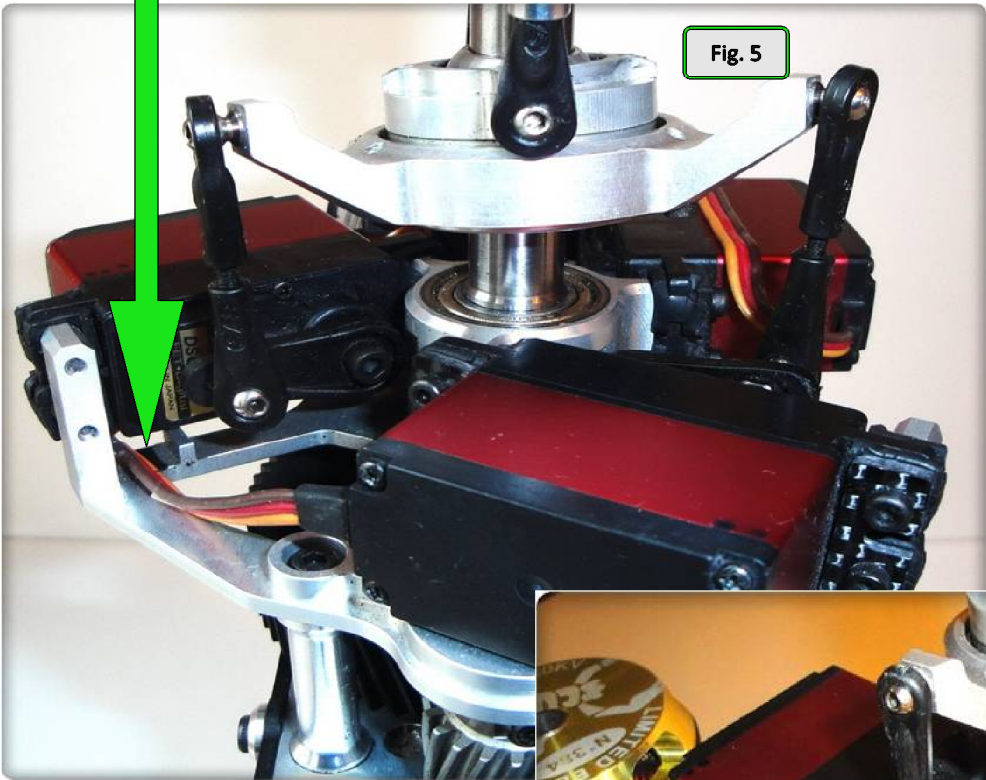

Bag 14

Tool HA002

If it is necessary to tighten the horn screw, use the included hexagonal wrench (HA002).

Bag 13

Plastic ball link (H0066-S)

Set Screw M2.5x18mm (HC140-S)

Plastic ball link (H0066-S)

Approx. 47.5mm

Initial length for the rods from the servos to the swash plate.

Approx. 19.5mm

Approx. 17.5mm

Approx. 66mm

Initial length for the rods from the swash plate to the blade grips.



DE-BURR THE SIDE FRAMES

We recommend de-burring the edges of the carbon parts in areas where electrical wires run.



ESC INSTALLATION

The electronic speed control (ESC) is installed in the front part of the helicopter. The support is made of aluminum, which further acts as a heat sink for the ESC. The figures below show the installation of three different brands of ESC.

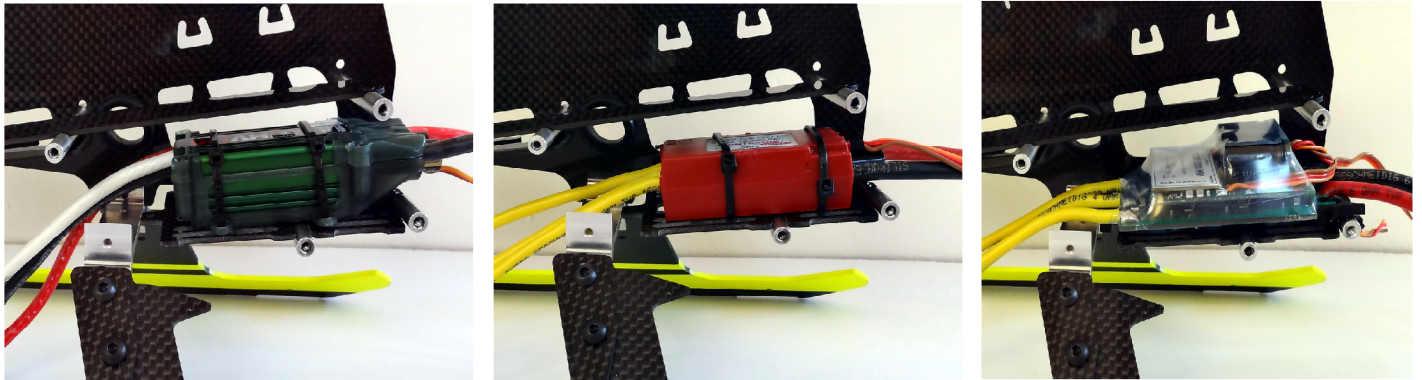

Figure 4: Shows the wiring which connects the receiver and ESC (in this picture one frame has been removed).
If the BEC used is combined with the ESC, it is recommended to use a dual wire connection.

Figure 5: The passage of the controller wires to the motor is highlighted.

Figure 6: Shows the installation of a 2S battery for the flight control system.
Alternatively, a BEC could be placed in the same area.

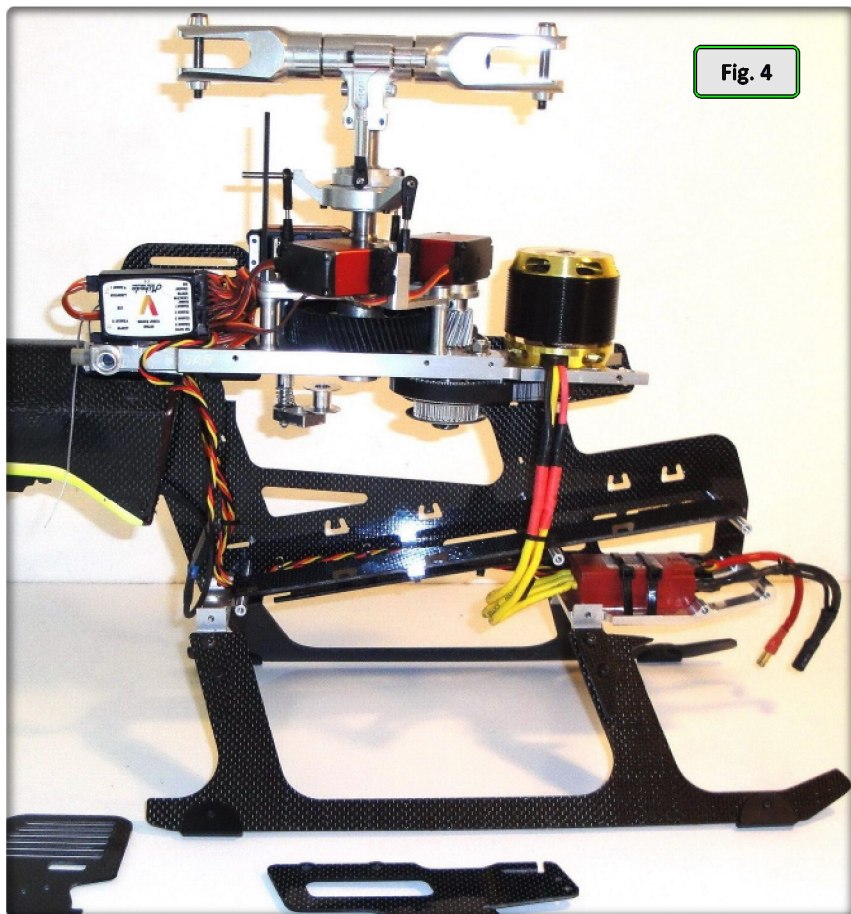
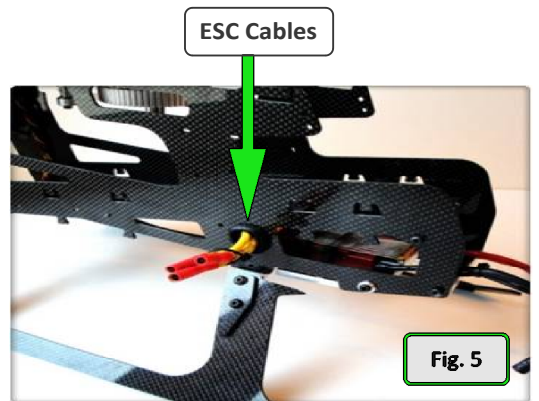

Fig. 4



ESC Cables

Fig. 5

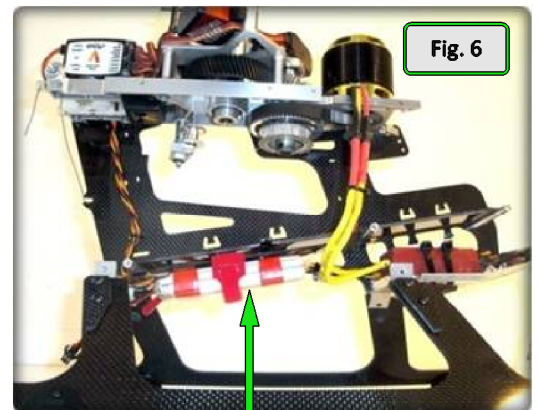

Fig. 6

2S Battery or BEC



FLYBARLESS CONTROL UNIT AND RX INSTALLATION

It is possible to install any commercially available Flybarless control unit in the goblin. For Flybarless systems with a separate sensor, the sensor must be installed under the plate (Figure 1). Figure 2 shows an example of installation of the receiver and flybarless control unit. In Figure 3 you can see the extension lead for the tail servo. It is very important to include a connector for fast disassembly of the boom module. The connector will prevent servo damage in case of boom separation during a crash.

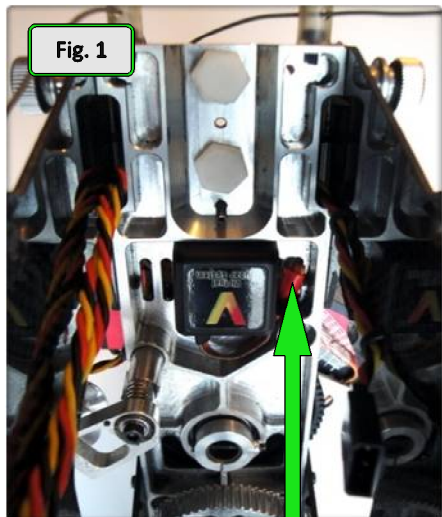

Slot for sensor cable

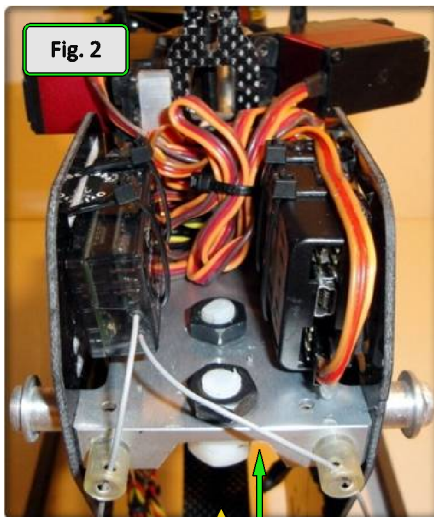

It is important to lock the plugs of the flybarless unit with an adhesive - for example hot glue.

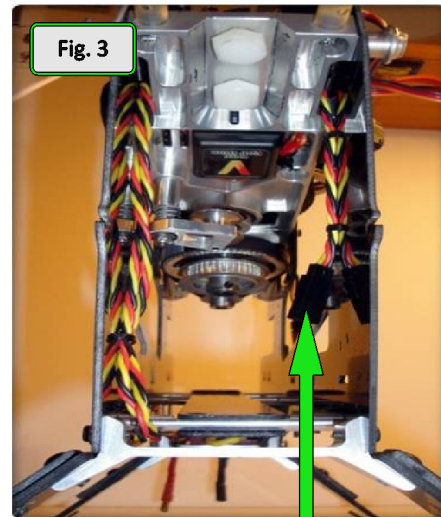

Tail servo extension cable

To install a one piece Flybarless system it is necessary to add the support shown in these figures. Figure 3 shows the installed support. Figure 4 shows the control unit and the receiver installed on the support.

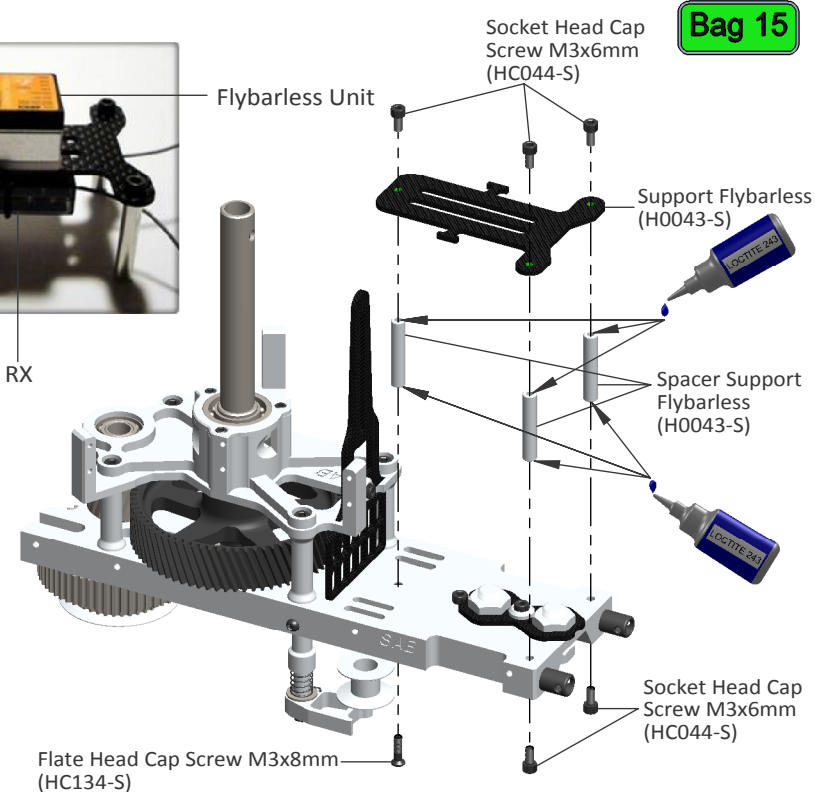
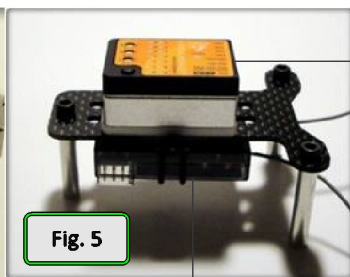
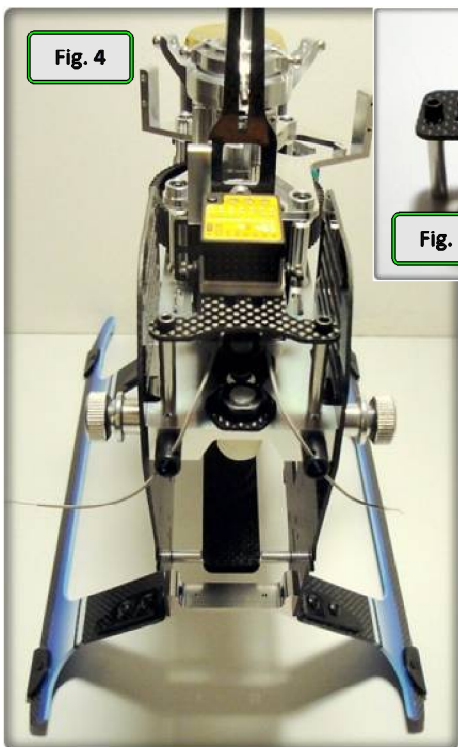

Bag 15



TRANSMISSION SETUP

It is important to choose the right reduction ratio to maximize efficiency based on your required flight performance. The Goblin has many possible reduction ratios at your disposal. It is possible to optimize any motor and battery combination. It is recommended to use wiring and connectors appropriate for the currents generated in a helicopter of this class.

If you are using a head speed calculator which requires a main gear and pinion tooth count, use 204 teeth for the main gear (this takes into account the two stage reduction) and the tooth count of your pulley as the pinion count.

Below is a list of available reduction ratios:

H0015-18-S - 18T Pinion = ratio 11.3:1	H0015-22-S - 22T Pinion = ratio 9.3:1
H0015-19-S - 19T Pinion = ratio 10.7:1	H0015-23-S - 23T Pinion = ratio 8.9:1
H0015-20-S - 20T Pinion = ratio 10.2:1	H0015-24-S - 24T Pinion = ratio 8.5:1
H0015-21-S - 21T Pinion = ratio 9.7:1	H0015-26-S - 26T Pinion = ratio 7.8:1

Some example configurations:

GOBLIN 630 CONFIGURATIONS							
Rev 01							
Performance	Battery	Motor	ESC	Pinion	Gov	RPM	Pitch
GENERAL	10S 4000	Scorpion HK 4035-560	Ice 120 HV (V2)	23T	Set Rpm	2120	± 12
			Jive 80 HV YGE 120HV	22T	Yes @80%	2150	± 12
		Kontronik Pyro 700-520	Ice 120 HV (V2)	24T	Set Rpm	2120	± 12
			Jive 80 HV YGE 120HV	23T	Yes @80%	2120	± 12
3D	12S 3300/3700	Scorpion HK 4035-560	Ice 120 HV (V2)	21T	Set Rpm	2300	± 12.5
			Jive 120 HV YGE 120HV	20T	Yes @80%	2320	± 12.5
		Quantum 4135-530	Ice 120 HV (V2)	22T	Set Rpm	2280	± 12.5
			Jive 120 HV YGE 120HV	21T	Yes @80%	2300	± 12.5
		Kontronik Pyro 700-520	Ice 120 HV (V2)	22T	Set Rpm	2250	± 12.5
			Jive 120 HV YGE 120HV	21T	Yes @80%	2280	± 12.5
		Scorpion HK 4225-610	Ice 120 HV (V2)	20T	Set Rpm	2350	± 12.5
			Jive 120 HV YGE 120HV	18T	Yes @80%	2350	± 12.5
HARD 3D	12S 3300/4000	Scorpion HK 4225-610	Jive 120 HV	19T	Yes @80%	2450	± 12.5

Note: Although the Goblin can fly at high rpm, for safety reasons we suggest to not exceed 2350 rpm.



MOTOR BELT TENSION

- *Assemble the motor and pinion to its mounting plate.
- *Fit the motor assembly into position.
- *Compress the springs by pushing the motor toward the main shaft.
- *At maximum compression, temporarily tighten one of the slide screws.
- *With the minimum centre distance it is easy to install the belt. First put the belt on the motor pinion.
- *Then put the belt around the big pulley.
- *Rotate the motor several times by hand.
- *Release the screw that locks the slide.
- *The springs keep the belt in tension.
- *Help the springs by pulling the motor slightly.
- *Lock all screws.

Figure 1 shows the motor correctly wired. It is advisable to cover the wire joints between the motor and the ESC with heat shrink tubing.



Fig. 1

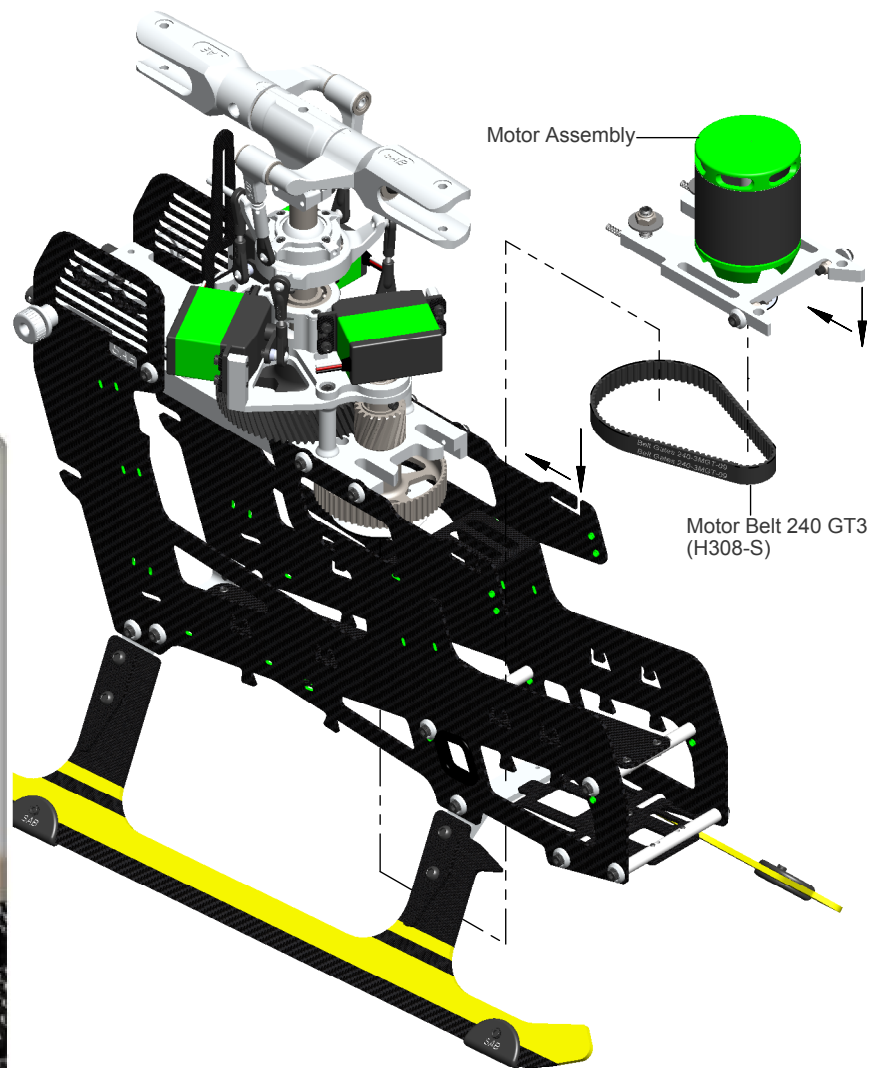



BOOM ASSEMBLY

- *Insert the tail boom assembly making sure that the aluminum part of the tube touches the M3x16 screw.
- *Lock the M8 nuts with the HA005 special tool supplied (Tray 2).
- *Firmly lock the lateral M3 nuts.
- *Assemble the H0038 carbon security plate .
- *Connect the tail servo wire to the previously fitted extension lead.

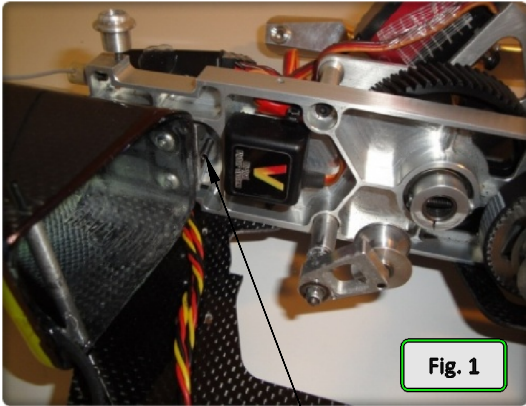

Fig. 1

The Socket Head Cap Screw M3x16mm correctly positions the boom assembly.

- Socket Head Cap Screw M3x8mm
- Finishing Washer M3

Bag 12

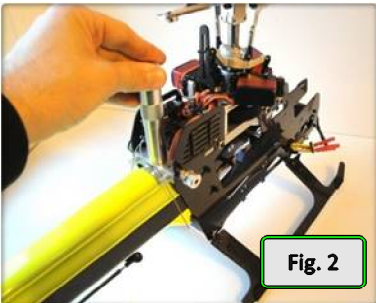
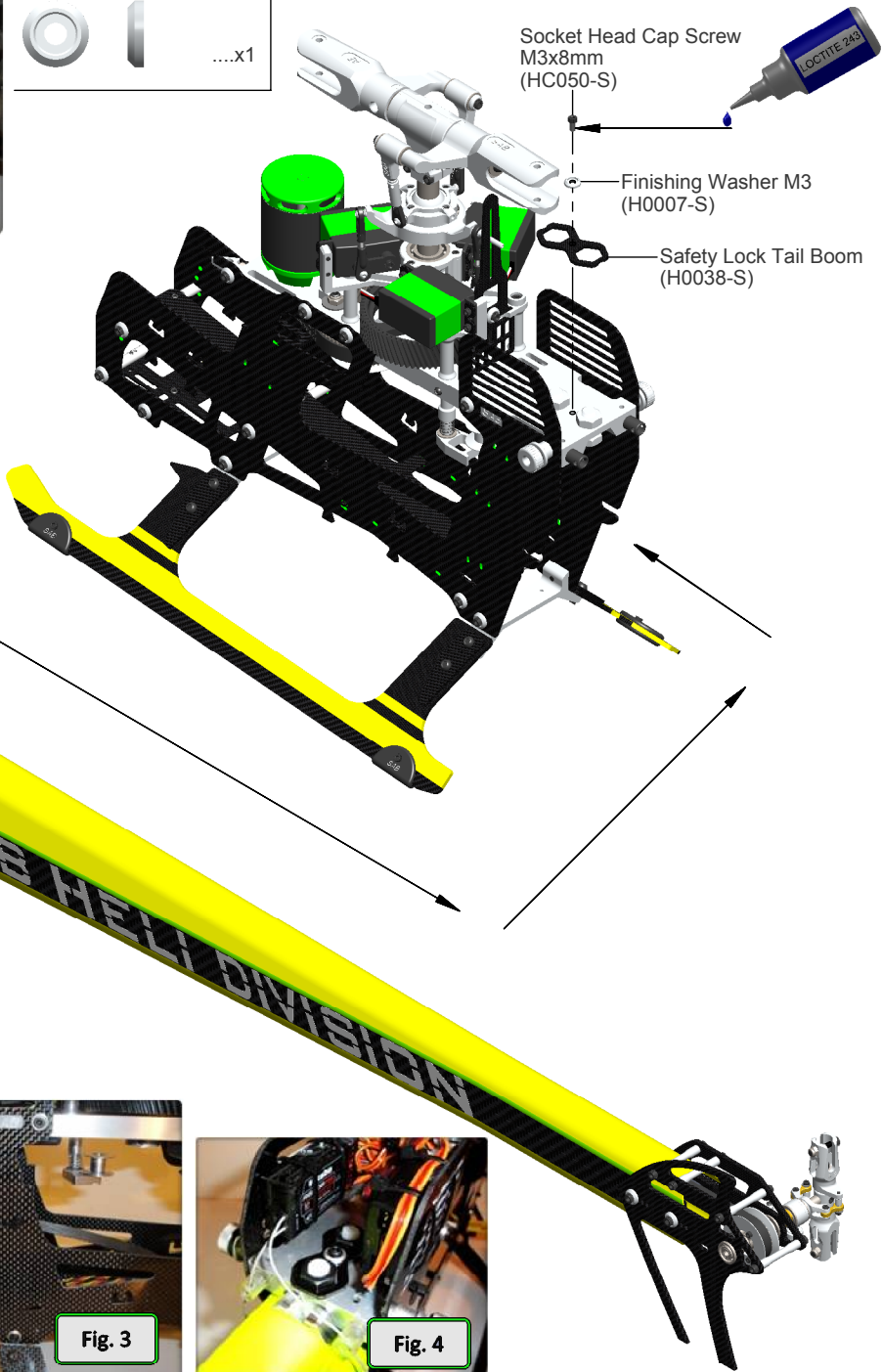

Fig. 2

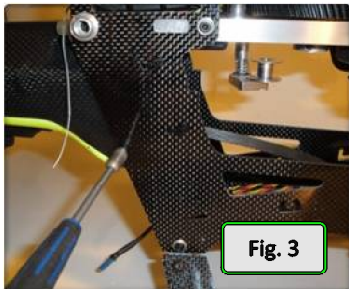

Fig. 3

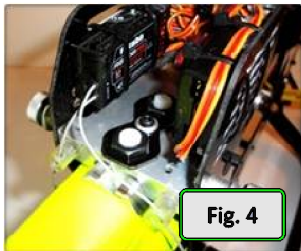

Fig. 4



TAIL BELT TENSION

- *Check the proper assembly of the tail boom.
- *Check that the aluminum part of the tube is against the M3 stop screw.
- *Loosen the tail group by loosening the 4 M3 screws.
- *Install the belt onto the pulley, taking care to respect the direction of rotation (figure 1).
- *Rotate the tail drive several times by hand.
- *Load the spring by rotating the tensioning arm 270° clockwise (when looking down from the top of the helicopter).
- *Tension the boom until the tensioning arm is aligned with the frame.
- *Tighten the 4 screws.
- *Check that the tail output shaft is perpendicular to the tube. (figure 2)
- *In figure 3,4,5 you can see the three conditions, ok, too loose and too tight.

NOTE. To disassemble the tail boom it is possible to remove the pulley H0016-S without loosening the tail unit. Remove the locking screw and pull down.

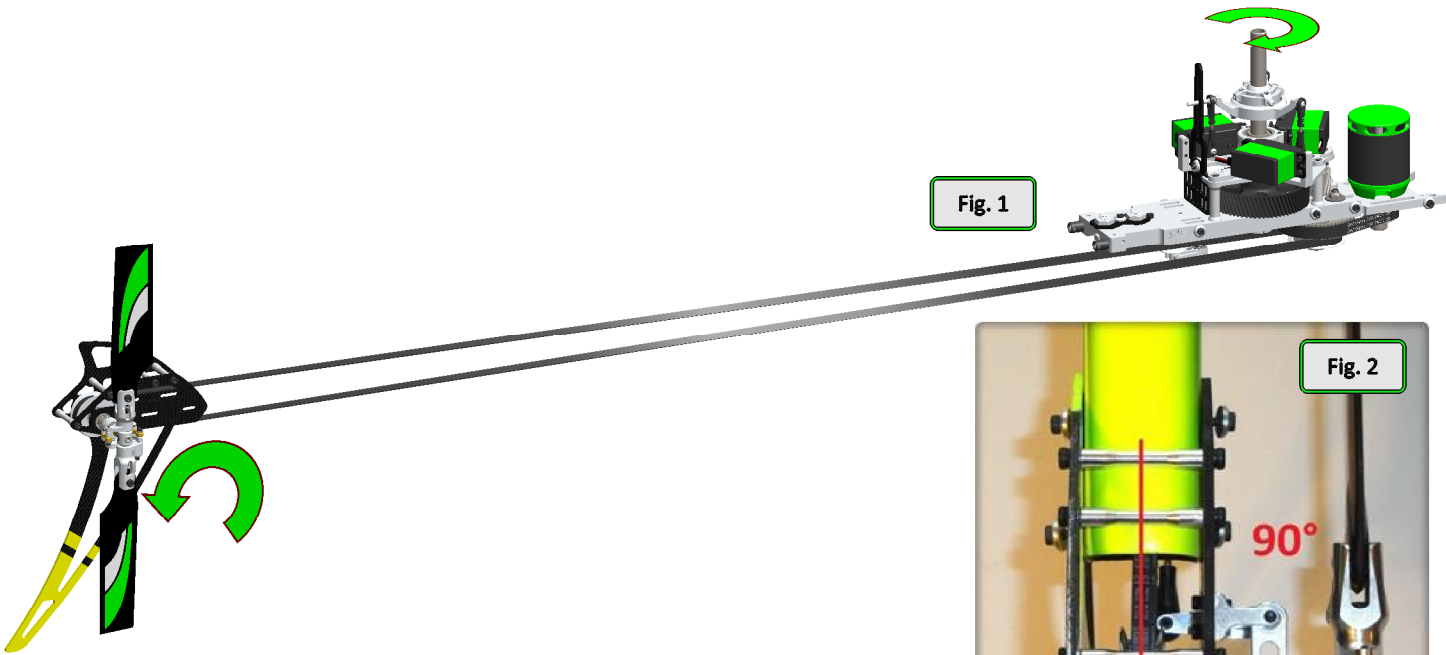

Fig. 1

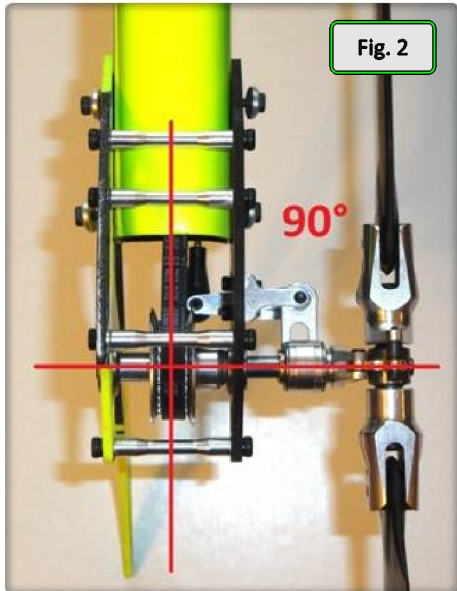

Fig. 2

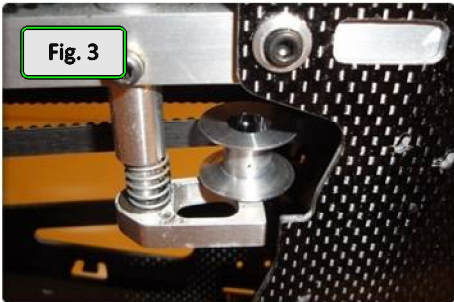

Fig. 3

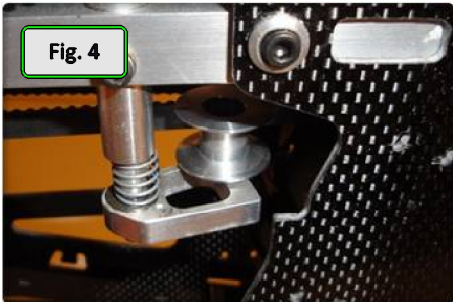

Fig. 4

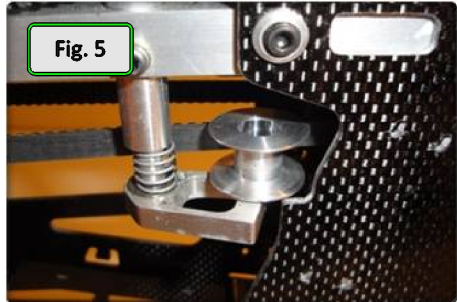

Fig. 5



BATTERIES

To secure the batteries, use the supplied O-rings HA012 [Bag 14]. Install them as shown in **figure 1**

To correctly secure the batteries it is necessary to use hook and loop type tape on the battery support and batteries themselves (**figure 2**).

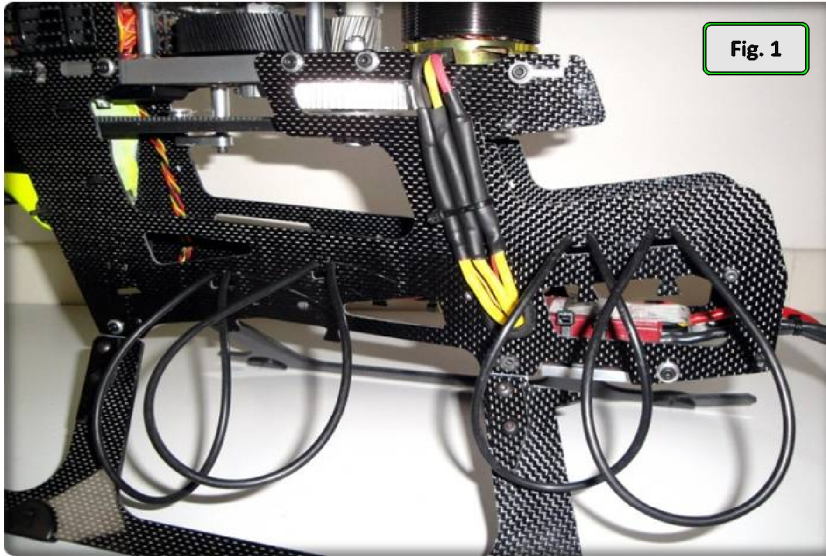

Fig. 1

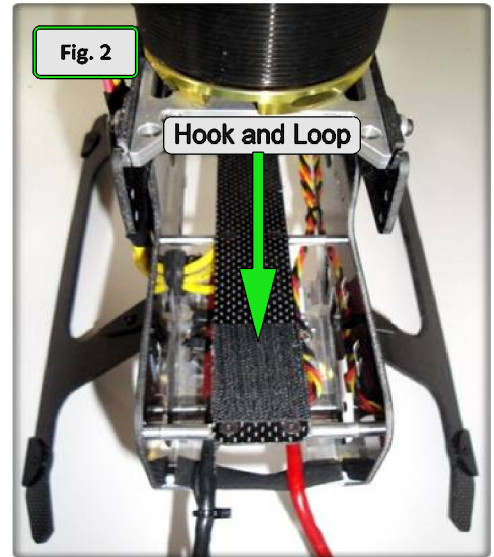

Fig. 2

CANOPY

On the Goblin, the canopy touches the frame. To avoid triggering vibration, it is necessary to attach an adhesive foam tape to the canopy HA006 [Bag 14] (**figure 3**).

The canopy is locked at the point shown in **figure 4** and with two H0036 knobs (both equipped with OR HA008 [Bag 14](**figure 5**)). Confirm the canopy is secure prior to each flight.



Fig. 5



Fig. 3



Fig. 4



OPERATIONS BEFORE FLIGHT

*Set up the remote control and the flybarless system with utmost care.

*It is advisable to test the correct settings of the remote and flybarless system without main blades or tail blades fitted.

! *Check that all wiring is isolated from the carbon/aluminum parts. It is good practice to protect them at the points where they are at most risk.

*Be sure of the gear ratio, verifying carefully the motor pulley in use. The forces acting on the mechanics increase enormously with increasing of rpm. Although the Goblin can fly at high rpm, for safety reasons we suggest to not exceed 2350 rpm.

*Check the correct tension of the tail belt through the belt tensioner.

*Fit the main blades and tail blades. (**Fig.1** and **Fig.2**)

*Please make sure the main blades are tight on the blade grips, you should be able to violently jerk the head in both directions and the blades should not fold. Failure to tighten the blades properly can result in a boom strike. To fold the blades for storage, it is advisable to loosen them.

*Check the collective and cyclic pitch. For **3D flight**, set about **+/- 12°-13°**.

*It is important to check the correct tracking of the main blades.

*On the Goblin, in order to correct the tracking, adjust the main link rod as shown in figure 3. This is provided with a right/left thread system that allows continuous fine adjustments of the length of the control rod; for this adjustment it is not necessary to detach the ball link.

! *Perform the first flight at a low headspeed, **1900/2000 RPM**.
After this first flight, do a general check of the helicopter. Verify that all screws are correctly tightened.

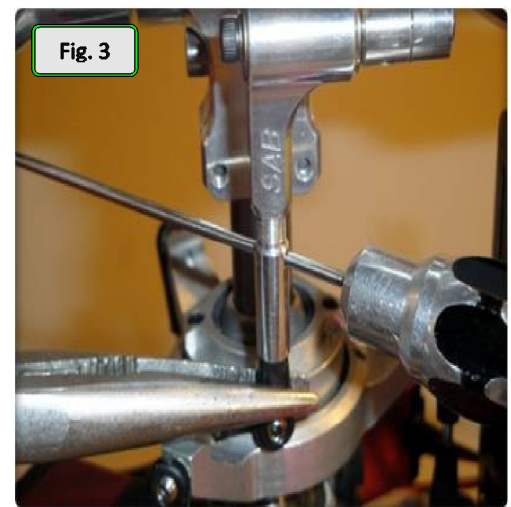
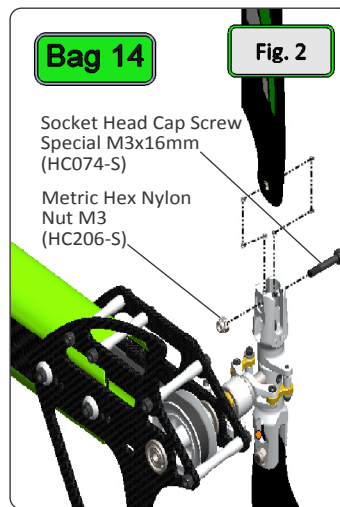
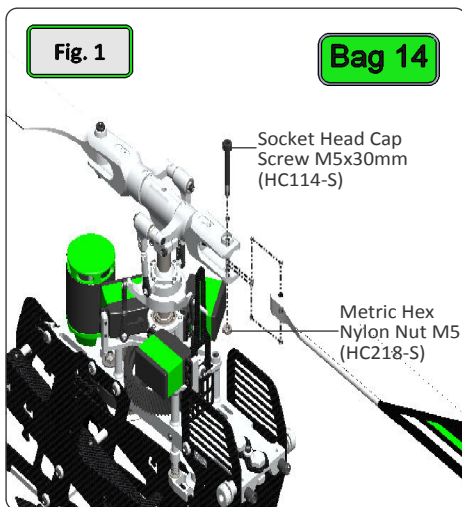

IN FLIGHT

During its first flights the Goblin has to be "run in".

The Damper, the main gear, the uniball and other parts must undergo some slight wear to operate smoothly. It is likely that during the very first flights the model may exhibit a swaying phenomena, particularly at low head speed.

This phenomena disappears after a few flights.

If you want to fly in a generic way, using both low headspeed and high headspeed, the standard setting is the best compromise.

However, if you prefer flying at low speed [**< 2100 rpm**], for best results we recommend changing the tail pulley for a smaller one to increase tail rotor rpm. In this way, you will have extremely precise tail control even at low RPM. This pulley is available in the upgrade list [**H0103-S**]

It is important to check the rigidity of the head dampening frequently. This can be adjusted by adding or removing shims to preload the dampers. If you notice a loss of head stiffness over time, add a 0.2 mm shim to each side (**HC232-S**). It is extremely important that the blade grips do not have sideways play in the head, the head is already assembled and preloaded with 2 shims, if needed you can find two extra shims in the box [**HC232 - Bag 14**].



MAINTENANCE

*On the Goblin, areas to look for wear include:

- * Motor belt
- * Tail belt
- * Damper
- * Main gear and pinion

The lifespan of these components varies according to the type of flying. On average it is recommended to replace these special parts every **100** flights.

*The head tends to lose rigidity after a while. Check this condition every **20** flights. Preloading with precision shim washers, it is possible to vary the rigidity of the head.

*Check all uniballs often.

*Check the head control linkages at the thread between the two aluminum parts (**figure 1**). The play present in this coupling is desired. Check after each flight that the play remains constant.

*The most stressed bearings are definitely those of the tail shaft. Check them frequently. All other parts are not particularly subject to wear.

*Periodically lubricate the tail slide movement and its linkages as well as the swashplate movement and its linkages.

*Lubricate the main gear with silicone or Tri-Flow Synthetic grease, even though the gear is made of technopolymer, a high mineral based filler, it still requires some lubrication.

*Check the screws that are highlighted in the following images frequently, making sure they remain tight (**fig.2** and **fig.3**).

*To ensure safety you should do a general inspection of the helicopter after each flight. You should check:

- * The maintenance of proper belt tension.
- * The proper isolation of wires from the carbon and aluminum parts.
- * That all screws remain tight.

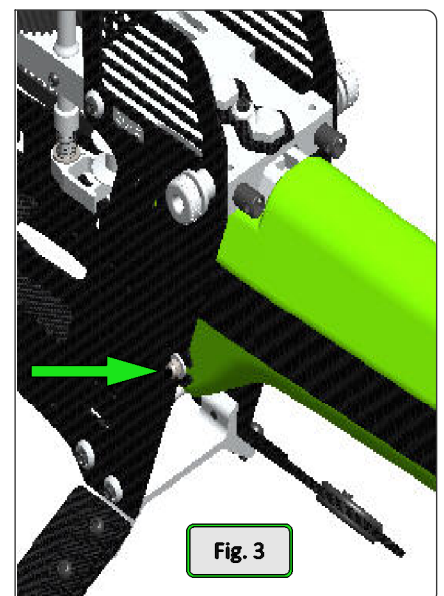
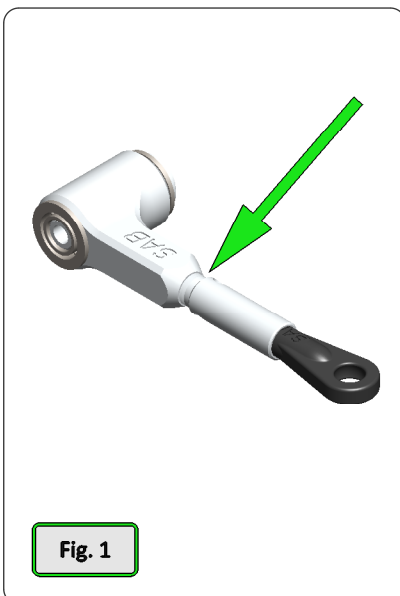

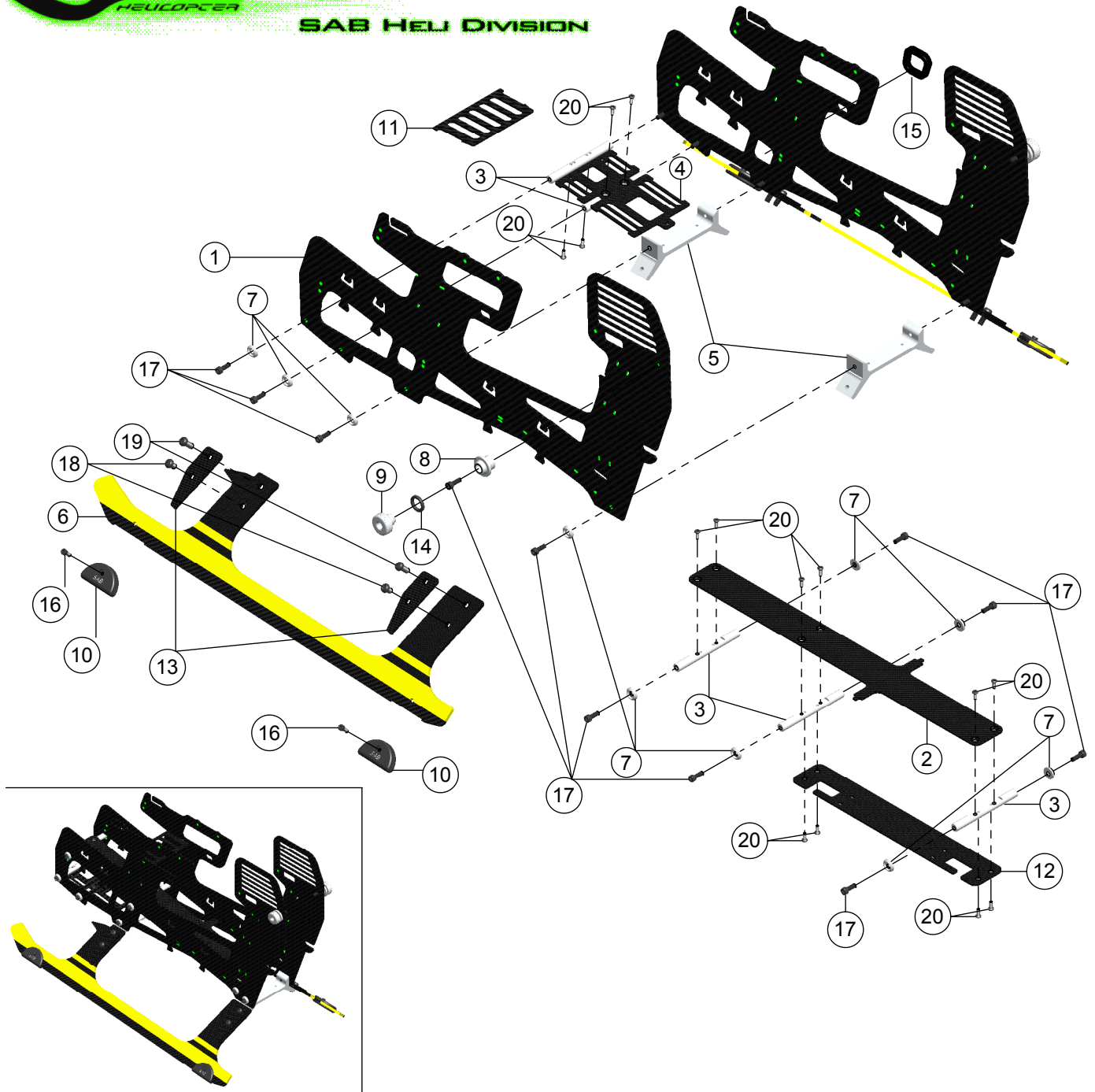

Main Frame				
POS	COD	Name	Specification	Quantity
1	H0001	Main Frame	Carbon Fiber	2
2	H0002	Battery Tray	Carbon Fiber	1
3	H0003	Frame Spacer	Aluminum	5
4	H0088	ESC Support	Carbon Fiber	1
5	H0005	Landing Gear Support	Aluminum	2
6	H0105	Landing Gear	Carbon Fiber	2
7	H0007	Finishing Washer M3	Aluminum	20
8	H0008	Canopy Positioner	Aluminum	2
9	H0036	Canopy Locking	Aluminum	2
10	H0039	Landing Gear Protection	Plastic	4

Main Frame				
POS	COD	Name	Specification	Quantity
11	H0042	Battery Protection	Carbon Fiber	1
12	H0073	Battery Support	Carbon Fiber	1
13	H0074	Landing Gear Strut	Carbon Fiber	4
14	HA008	Canopy OR	Oring 3030	2
15	HA010	Cable Pass	∅ 16 x ∅ 24 x 2mm	1
16	HC018	Socket Head Cap Screw	M2.5 x 6mm	4
17	HC050	Socket Head Cap Screw	M3 x 8mm	22
18	HC096	Button Head Cap Screw	M4 x 6mm	4
19	HC100	Button Head Cap Screw	M4 x 10mm	4
20	HC128	Flat Head Cap Screw	M2.5 x 5mm	14

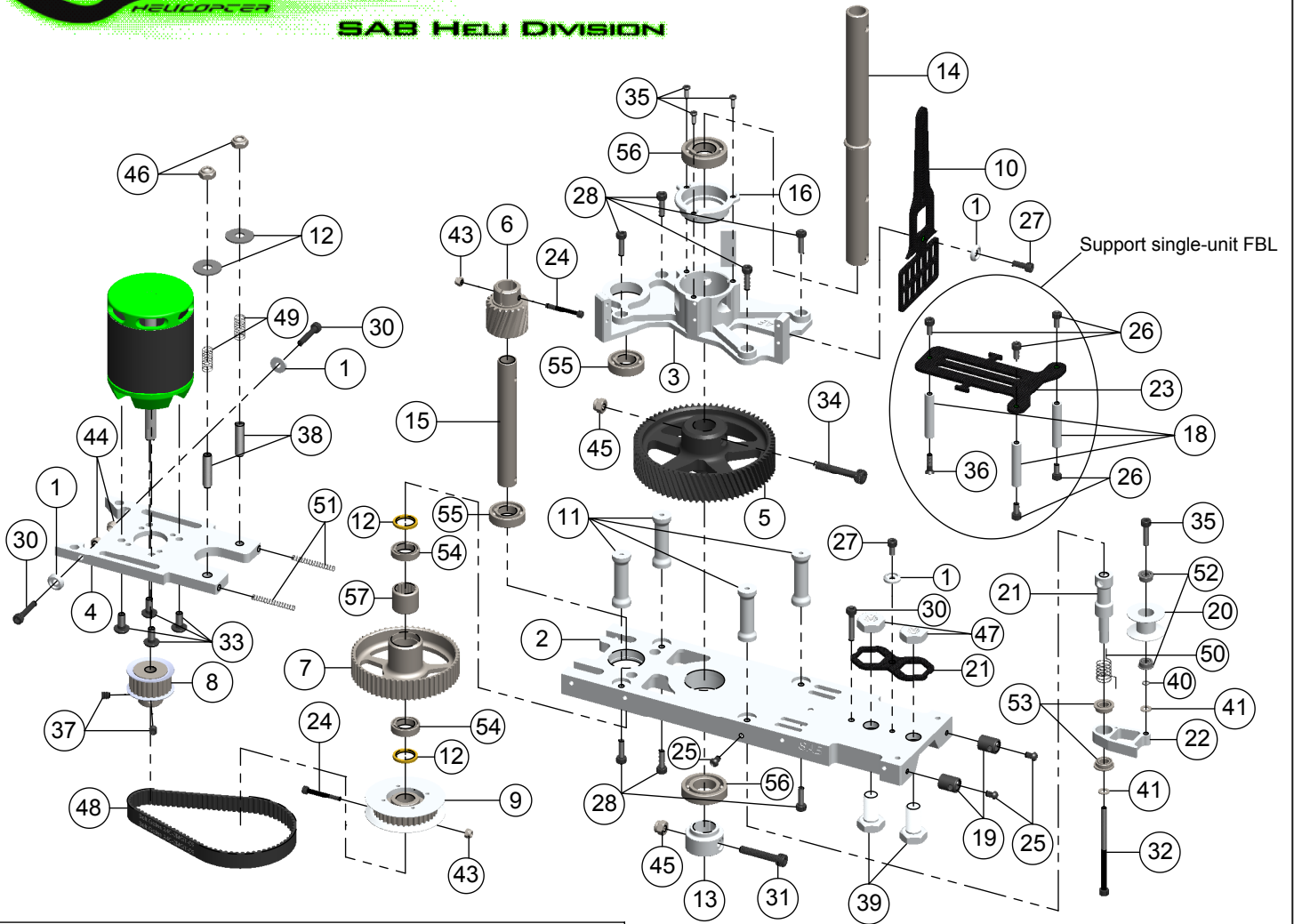

TRANSMISSION ASSEMBLY				
POS	COD	Name	Specification	Quantity
1	H0007	Finishing Washers M3	Aluminum	4
2	H0009	Main Structure	Aluminum	1
3	H0010	Servo Support	Aluminum	1
4	H0011	Motor Support	Aluminum	1
5	H0012	Main Gear	68T M1	1
6	H0125	Drive Pinion	20T M1	1
7	H0104	Pulley	60T	1
8	H0015-20	Pulley	20T	1
9	H0101	Pulley	37T	1
10	H0017	Swash plate Anti-Rotation Guide	Carbon Fiber	1
11	H0018	Columns	Aluminum	4
12	H0110	Bush-One Ways	Ø10 x Ø13 x 1.4mm	2
13	H0121	M4 Locking Collar		1
14	H0122	Main Shaft		1
15	H0022	Tail Shaft		1
16	H0024	Main Shaft Bearing Support		1
17	H0038	Safety Locking Tail Boom	Carbon Fiber	1
18	H0043	Spacers Flybarless		3
19	H0050	Antenna Guide	Plastic	2
20	H0069	Tail Belt Idler		1
21	H0070	Belt Tensioner Support		1
22	H0071	Belt Tensioner Arm		1
23	H0077	Flybarless Support	Carbon Fiber	1
24	HC033	Socket Head Cap Screw Shouldered	M2.5 x 19mm	2
25	HC038	Button Head Cap Screws	M3 x 4mm	3
26	HC044	Socket Head Cap Screws	M3 x 6mm	5
27	HC050	Socket Head Cap Screws	M3 x 8mm	2
28	HC056	Socket Head Cap Screws	M3 x 10mm	7
29	HC062	Socket Head Cap Screw	M3 x 12mm	1

TRANSMISSION ASSEMBLY				
POS	COD	Name	Specification	Quantity
30	HC068	Socket Head Cap Screws	M3 x 16mm	3
31	HC104	Socket Head Cap Screw	M4 x 22mm	1
32	HC092	Socket Head Cap Screw	M3 x 50mm	1
33	HC098	Button Head Cap Screws	M4 x 8mm	4
34	HC111	Socket Head Cap Screw Shouldered	M4 x 24mm	1
35	HC128	Flat Head Cap Screws	M2.5 x 5mm	3
36	HC134	Flat Head Cap Screw	M3 x 8mm	1
37	HC152	Set Screws	M4 x 4mm	2
38	HC158	Set Screws	M5 x 20mm	2
39	HC164	Vite Nylon Esa	M8 x 14mm	2
40	HC176	Washer	Ø3 x Ø4x0.5mm	1
41	HC180	Washers	Ø3.2 x Ø6 x 0.5mm	2
42	HC188	Washers	Ø5.3 x Ø15 x 1mm	2
43	HC200	Metric Hex Nylon Nuts	M2.5 H3.5mm	2
44	HC206	Metric Hex Nylon Nuts	M3 H4mm	2
45	HC212	Metric Hex Nylon Nuts	M4 H5mm	2
46	HC218	Metric Hex Nylon Nuts	M5 H4.8mm	2
47	HC224	Metric Hex Nuts Low	M8 H6.5mm	2
48	HC308	Belt Gates	240-3MGT-13	1
49	HC310	Springs	De 5.8-df0.3-LL9	2
50	HC312	Spring	De 8-df0.5-LL8	1
51	HC314	Springs	De 8-df0.7-LL12	2
52	HC402	Flanged Bearings	Ø3 x Ø7 x 3mm	2
53	HC410	Flanged Bearings	Ø5 x Ø9 x 3mm	2
54	HC420	Bearings	Ø10 x Ø15 x 4mm	2
55	HC422	Bearings	Ø10 x Ø19 x 5mm	2
56	HC426	Bearings	Ø12 x Ø24 x 6mm	2
57	HC442	One Way Bearing	Ø10 x Ø14 x 12mm	1



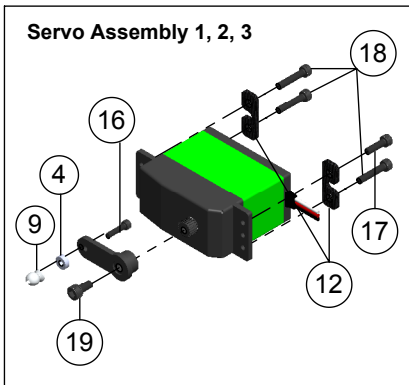
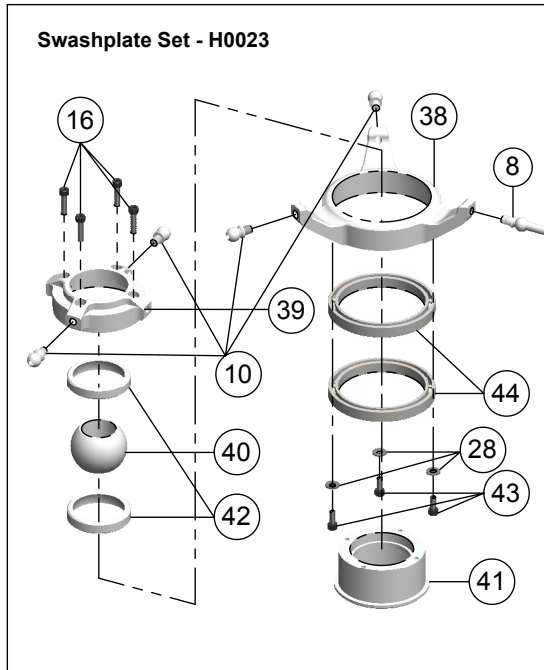
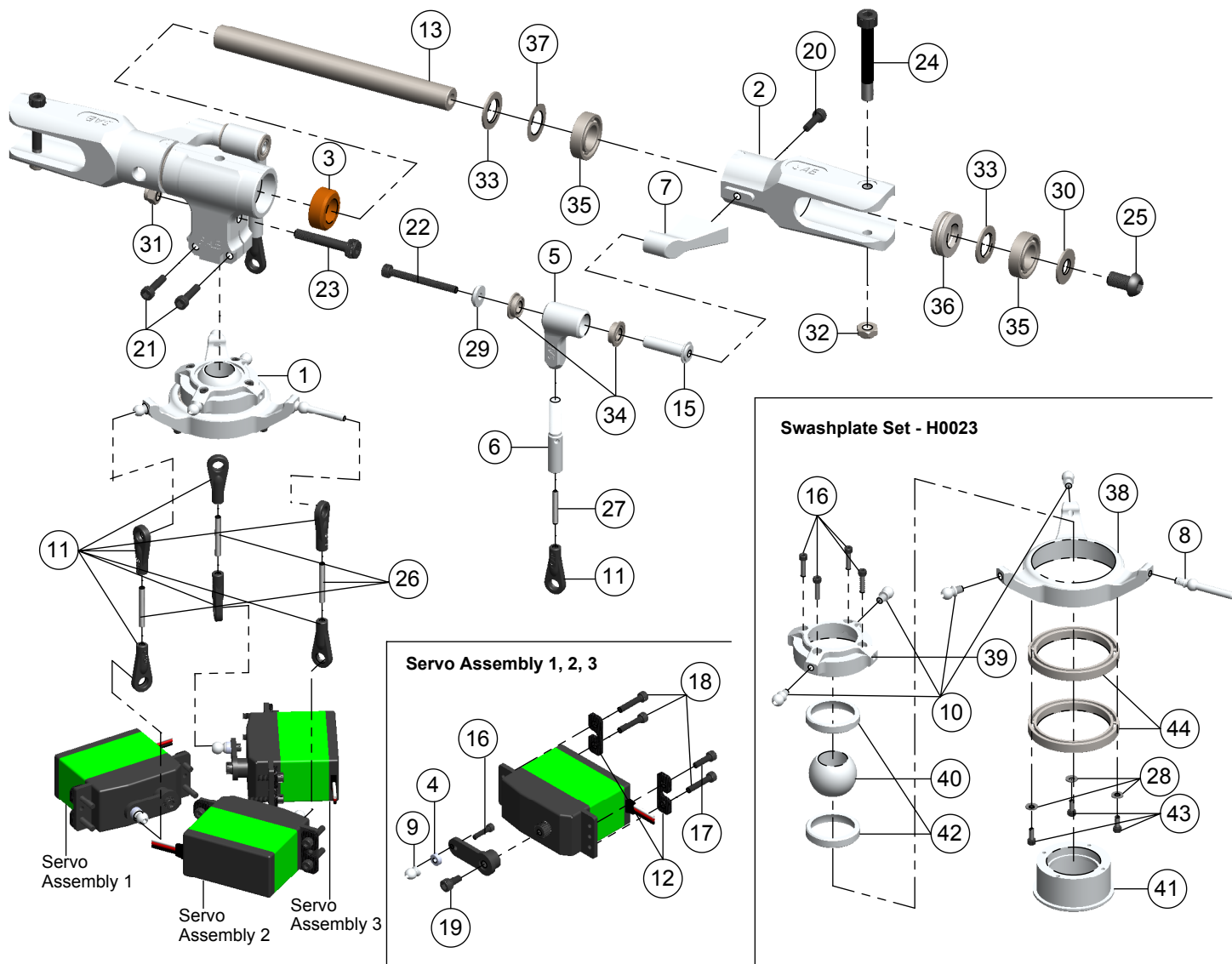

Head System				
POS	COD	Name	Specification	Quantity
1	H0023	Swashplate Set		1
2	H0086	Main Blade Grip	Aluminum	2
3	H0027	Damper Hard		2
4	H0031	Uniball Spacer		3
5	H0032	Blade Grip Link	Aluminum	2
6	H0033	Main Linkage	Aluminum	2
7	H0087	Blade Grip Arm	Aluminum	2
8	H0063	Uniball	M3 x 4 Ø5 H18	1
9	H0064	Uniball	M2.5 Ø5 H6	3
10	H0065	Uniball	M3 x 4 Ø5 H3	4
11	H0066	Plastic Ball Linkage	Plastic	8
12	H0075	Servo Spacer	Carbon Fiber	6
13	H0097	Spindle		1
14	H0080	Center Hub	Aluminum	1
15	H0085	Center Blade Grip Arm	Aluminum	2
16	HC008	Socket Head Cap Screw	M2 x 8mm	7
17	HC020	Socket Head Cap Screw	M2.5 x 8mm	3
18	HC026	Socket Head Cap Screw	M2.5 x 12mm	9
19	HC044	Socket Head Cap Screw	M3 x 6mm	2
20	HC056	Socket Head Cap Screw	M3 x 10mm	2
21	HC062	Socket Head Cap Screw	M3 x 12mm	2
22	HC090	Socket Head Cap Screw	M3 x 30mm	2

Head System				
POS	COD	Name	Specification	Quantity
23	HC111	Socket Head Cap Screw Shouldered	M4 x 24mm	1
24	HC114	Socket Head Cap Screw Shouldered	M5 x 30mm	2
25	HC122	Button Head Cap Screw	M6 x 10mm	2
26	HC140	Set Screw	M2.5 x 18mm	3
27	HC146	Set Screw	M2.5 x 15mm	2
28	HC170	Washer	Ø2 x Ø5 x 0.5mm	3
29	H0007	Finishing Washer	M3	2
30	HC194	Washer	Ø6 x Ø14 x 1.5mm	2
31	HC212	Metric Hex Nylon Nut	M4 H5	1
32	HC218	Metric Hex Nylon Nut	M5 H4.8	2
33	HC230	Washer	Ø10 x Ø16 x 1mm	4
34	HC410	Flanged Bearing	Ø5 x Ø9 x 3mm	4
35	HC422	Bearing	Ø10 x Ø19 x 5mm	4
36	HC438	Thrust Bearing	Ø10 x Ø18 x 5.5mm	2
37	HC232	Washer	Ø10 x Ø16 x 0.2mm	2
38	H0023-01	Swashplate 01		1
39	H0023-02	Swashplate 02		1
40	H0023-03	Swashplate 03		1
41	H0023-04	Swashplate 04		2
42	H0023-05	Swashplate 05		1
43	HC002	Socket Head Cap Screw	M2 x 5mm	3
44	HC430	Bearing Rad	Ø30 x Ø37 x 4mm	2

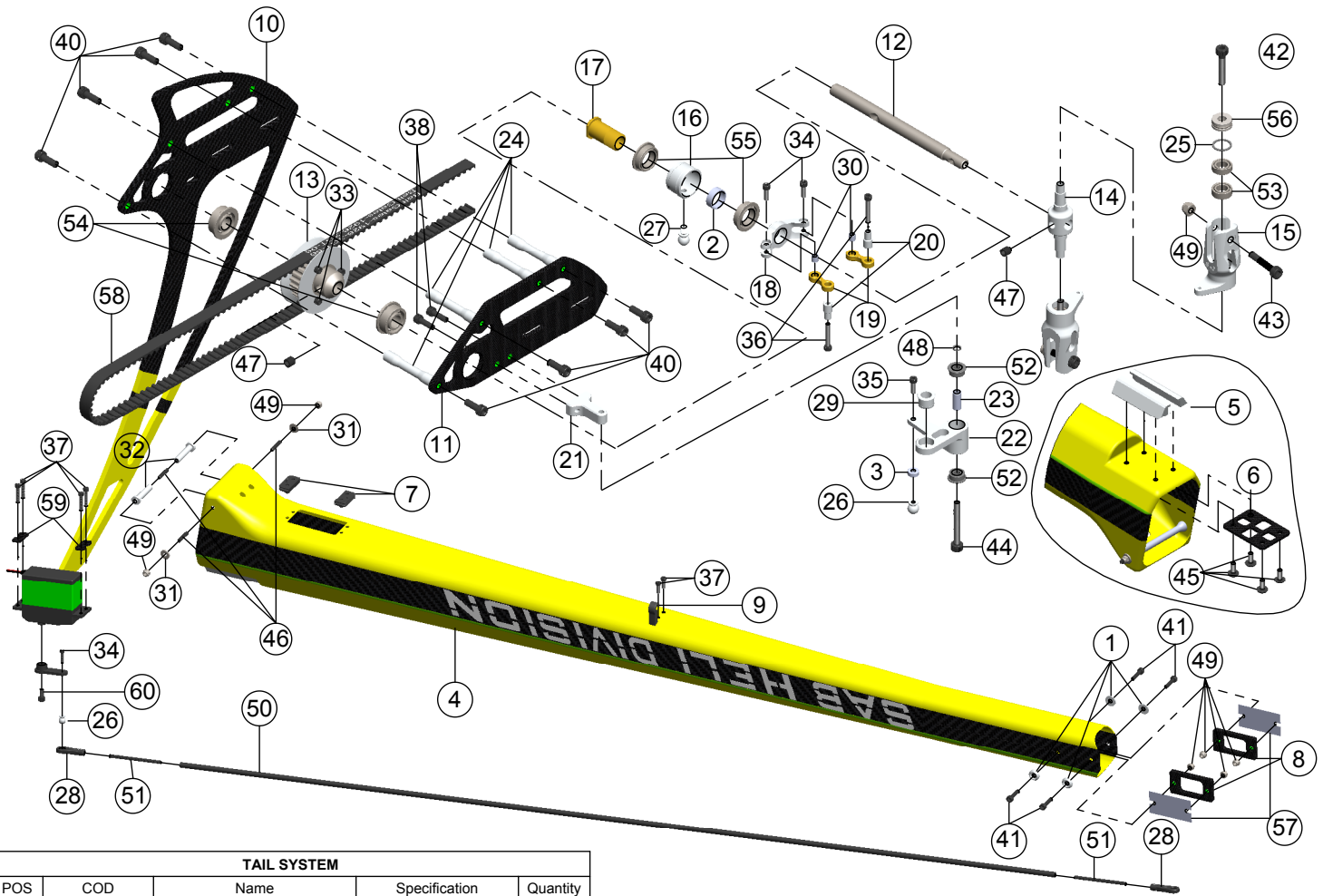

TAIL SYSTEM







POS	COD	Name	Specification	Quantity
1	H0007	Finishing Washer M3	Aluminum	4
2	H0029	Spacer	Ø8.1 x Ø9.2 x 3.2mm	1
3	H0031	Uniball Spacer		1
4	H0092	Tail Boom	Carbon Fiber	1
5	H0037-01	Tail Boom Interface	Aluminum	1
6	H0037-02	Locking Interface	Carbon Fiber	1
7	H0040	Tail Servo Locks	Plastic	2
8	H0041	Locking Element Tails	Carbon Fiber	2
9	H0045	Linkage Tail Support	Plastic	1
10	H0046	Vertical Fin	Carbon fiber	1
11	H0047	Tail Side Plate	Carbon fiber	1
12	H0048	Tail Rotor Shaft		1
13	H0102	Tail Pulley	27T	1
14	H0051	Tail Rotor Hub		1
15	H0052	Tail Blade Grips	Aluminum	2
16	H0053	Tail Pitch Slider 01		1
17	H0054	Tail Pitch Slider 02		1
18	H0055	Tail Pitch Slider 03		1
19	H0056	Grip Links		2
20	H0057	Main Grip Link Bushs		2
21	H0058	Bell Crank Base	Aluminum	1
22	H0059	Bell Crank Lever	Aluminum	1
23	H0060	Spacer	Ø3 x Ø4 x 9.6mm	1
24	H0061	Tail Case Spacers	Aluminum	4
25	H0062	Spacers	Ø7 x Ø9 x 0.5mm	2
26	H0064	Uniballs	M2.5 Ø5 H6	2
27	H0065	Uniball	M3 x 4 Ø5 H3	1
28	H0066	Plastic Ball Links	Plastic	2
29	H0072	Bush Bell Crank		1
30	H0076	Grip Link Bushs		2
31	H0078	Washers	Ø3.1 x Ø12 x 1.8mm	2

TAIL SYSTEM

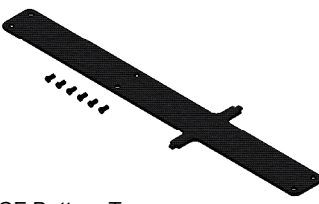
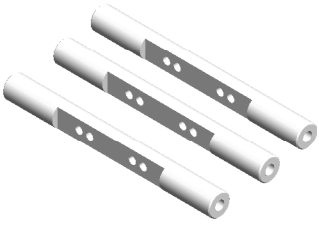
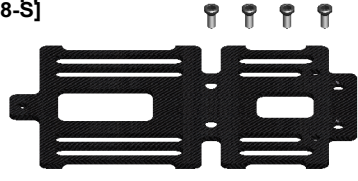



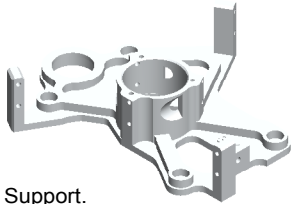

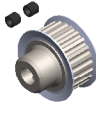
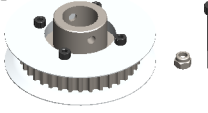





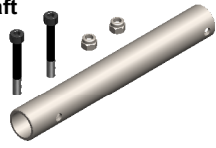

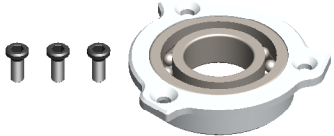
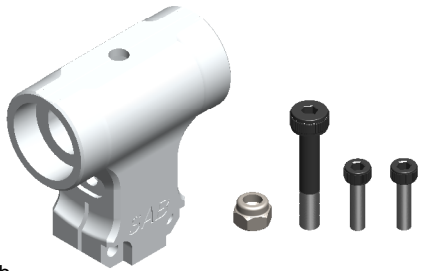
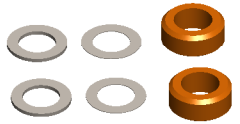

POS	COD	Name	Specification	Quantity
32	H0082	Boom Spacers		2
33	HC002	Socket Head Cap Screws	M2 x 5mm	6
34	HC004	Socket Head Cap Screws	M2 x 6mm	3
35	HC008	Socket Head Cap Screw	M2 x 8mm	1
36	HC014	Socket Head Cap Screws	M2 x 12mm	2
37	HC018	Socket Head Cap Screws	M2.5 x 6mm	2
38	HC020	Socket Head Cap Screws	M2.5 x 8mm	2
39	HC026	Socket Head Cap Screws	M2.5 x 12mm	4
40	HC050	Socket Head Cap Screws	M3 x 8mm	8
41	HC062	Socket Head Cap Screws	M3 x 12mm	4
42	HC068	Socket Head Cap Screws	M3 x 16mm	2
43	HC074	Socket Head Cap Screw Shoulderreds	M3 x 16mm	2
44	HC086	Socket Head Cap Screw	M3 x 22mm	1
45	HC098	Button Head Cap Screws	M4 x 8mm	4
46	HC150	Set Screws	M3 x 20mm	3
47	HC152	Set Screws	M4 x 4mm	2
48	HC176	Washer	Ø3 x Ø4 x 0.5mm	1
49	HC206	Metric Hex Nylon Nuts	M3	8
50	HC237	Carbon Rod	Ø2.5 x Ø4 x 635mm	1
51	HC242	Threaded Rods	M2.5 x 40mm	2
52	HC402	Flanged Bearings	Ø3 x Ø7 x 3mm	2
53	HC406	Bearings	Ø5 x Ø9 x 3mm	4
54	HC414	Flanged Bearings	Ø6 x Ø13 x 5mm	2
55	HC418	Flanged Bearings	Ø8 x Ø12 x 3.5mm	2
56	HC434	Thrust Bearings	Ø4 x Ø9 x 4mm	2
57	HA015	Double-Sided Tapes		2
58	HC324	Belt Gates	1926-3GT-06	1
59	H0075	Servo Spacers	Carbon Fiber	2
60		Screw supplied with Servo		1



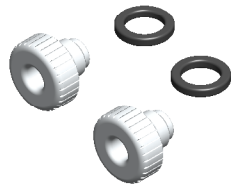

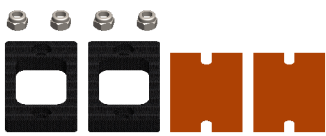









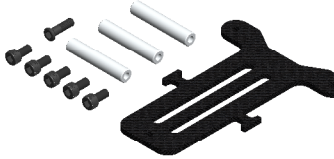



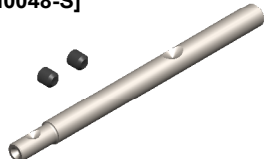
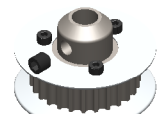
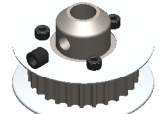

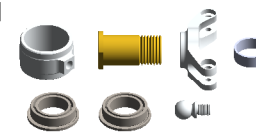
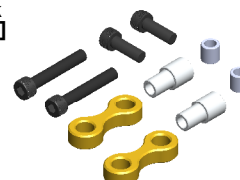

<p>Main Frame [H0001-S]</p>  <p>- 1 x CF Main Frame.</p>	<p>Battery Tray [H0002-S]</p>  <p>- 1 x CF Battery Tray. - 6 x Flat Head Cap Screws M2.5x5mm.</p>	<p>Frame Spacer [H0003-S]</p>  <p>- 3 x Frame Spacers.</p>			
<p>ESC Support [H0088-S]</p>  <p>- 1 x CF ESC Support. - 4 x Flat Head Cap Screws M2.5x5mm.</p>	<p>Landing Gear Support [H0005-S]</p>  <p>- 1 x Landing Gear Support.</p>	<p>Landing Gear Low Profile [H0106-S]</p>  <p>- 1 x CF Landing Gear Low Profile.</p>			
<p>Finishing Washer M3 [H0007-S]</p>  <p>- 10 x Finishing Washers M3.</p>	<p>Canopy Positioner [H0008-S]</p>  <p>- 2 x Canopy Positioners.</p>	<p>Main Structure [H0009-S]</p>  <p>- 1 x Main Structure.</p>	<p>Servo Support [H0010-S]</p>  <p>- 1 x Servo Support.</p>		
<p>Motor Support [H0011-S]</p>  <p>- 1 x Motor Support. - 2 x Set Screws M5x20mm. - 2 x Washers 5.3x15x1mm. - 2 x Metric Hex Nylon Nuts M5H4.8. - 2 x Finishing Washers M3. - 2 x Socket Head Cap Screws M3x16mm. - 2 x Metric Hex Nylon Nuts M3H4. - 2 x Springs de 5.8/ df0.5 / LL9. - 2 x Springs de 3/ df0.5 / LL12.</p>	<p>68T Main Gear [H0012-S]</p>  <p>- 1 x 68T Main Gear . - 1 x Socket Head Cap Screw Shouldered M4x24mm. - 1 x Metric Hex Nylon Nut M4 H5.</p>	<p>20T Drive Pinion [H0125-S]</p>  <p>- 1 x 20T Drive Pinion. - 1 x Socket Head Cap Screw Shouldered M2.5x19mm. - 1 x Metric Hex Nylon Nut M2.5 H3.5.</p>	<p>60T Pulley [H0104-S]</p>  <p>- 1 x 60T Pulley . - 2 x Bush One Ways. - 2 x Bearings 10x15x4mm - 1 x One Way Bearing 10x14x12mm.</p>		
<p>16T Pulley [H0015-16-S]</p>  <p>- 1 x 16T Pulley. - 2 x Set Screws M4x4.</p>	<p>18T Pulley [H0015-18-S]</p>  <p>- 1 x 18T Pulley. - 2 x Set Screws M4x4.</p>	<p>19T Pulley [H0015-19-S]</p>  <p>- 1 x 19T Pulley. - 2 x Set Screws M4x4.</p>	<p>20T Pulley [H0015-20-S]</p>  <p>- 1 x 20T Pulley. - 2 x Set Screws M4x4.</p>	<p>21T Pulley [H0015-21-S]</p>  <p>- 1 x 21T Pulley. - 2 x Set Screws M4x4.</p>	<p>22T Pulley [H0015-22-S]</p>  <p>- 1 x 22T Pulley. - 2 x Set Screws M4x4.</p>
<p>23T Pulley [H0015-23-S]</p>  <p>- 1 x 23T Pulley. - 2 x Set Screws M4x4.</p>	<p>24T Pulley [H0015-24-S]</p>  <p>- 1 x 24T Pulley. - 2 x Set Screws M4x4.</p>	<p>26T Pulley [H0015-26-S]</p>  <p>- 1 x 26T Pulley. - 2 x Set Screws M4x4.</p>	<p>37T Pulley [H0101-S]</p>  <p>- 1 x 37T Pulley. - 4 x Socket Head Cap Screws M2x8mm - 1 x Socket Head Cap Screw Shouldered M2.5x19mm. - 1 x Metric Hex Nylon Nut M2.5H3.5.</p>	<p>Swashplate Anti-Rotation Guide [H0017-S]</p>  <p>- 1 x CF Swashplate Anti-Rotation Guide. - 1 x Finishing Washer M3. - 1 x Socket Head Cap Screw M3x8mm.</p>	

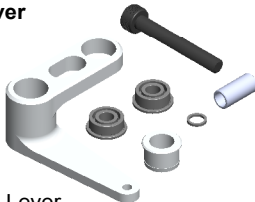
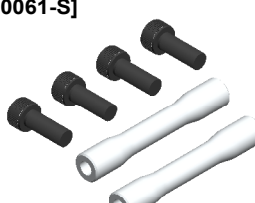

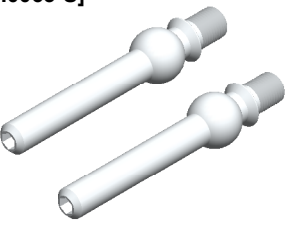
<p>Column [H0018-S]</p>  <p>- 4 x Columns.</p>	<p>M4 Locking Collar [H0121-S]</p>  <p>- 1 x M4 Locking Collar. - 1 x Socket Head Cap Screw M4x22mm. - 1 x Metric Hex Nylon Nut M4 H5.</p>	<p>Main Shaft [H0122-S]</p>  <p>- 1 x Main Shaft. - 1 x M4 Locking Collar - 2 x Socket Head Cap Screws Shouldered M4x24mm. - 1 x Socket Head Cap Screw M4x22mm. - 3 x Metric Hex Nylon Nuts M4 H5.</p>	<p>Secondary Shaft [H0022-S]</p>  <p>- 1 x Secondary Shaft. - 2 x Socket Head Cap Screws Shouldered M2.5x19mm. - 2 x Metric Hex Nylon Nut M2.5 H2.5.</p>
<p>Swashplate [H0023-S]</p>  <p>- 1 x Swashplate Assembly. - 2 x Bearings 30x Ø37x4mm. - 4 x Uniballs M3x4 Ø5 H3. - 1 x Uniball M3x4 Ø5 H18. - 3 x Socket Head Cap Screws M2x5mm. - 4 x Socket Head Cap Screws M2x8mm.</p>	<p>Bearing Support [H0024-S]</p>  <p>- 1 x Bearing Support. - 1 x Bearing Ø12xØ24x6mm. - 3 x Flat Head Cap Screws M2.5x5mm.</p>	<p>Center Hub [H0026-S]</p>  <p>- 1 x Center Hub. - 1 x Socket Head Cap Screw Shouldered M4x24mm. - 1 x Metric Hex Nylon Nut M4 H5. - 2 x Socket Head Cap Screws M3x12mm.</p>	
<p>Damper [H0027-S]</p>  <p>- 2 x Dampers. - 2 x Shims Ø10xØ16x1mm. - 2 x Shims Ø10xØ16x0.2mm.</p>	<p>Spindle [H0097-S]</p>  <p>- 1 x Spindle. - 2 x Button Head Cap Screws M6x10mm. - 2 x Washers Ø6xØ14x1mm.</p>	<p>Blade Grip Arm [H0032-S]</p>  <p>- 2 x Blade Grip Arms. - 4 x Flange Bearings Ø5xØ9x3mm (MF95ZZ).</p>	<p>Main Linkage [H0033-S]</p>  <p>- 2 x Main Linkages. - 2 x Plastic Balls Link. - 2 x Set Screws M2.5x15mm.</p>
<p>Blade Grip [H0086-S]</p>  <p>- 1 x Blade Grip. - 1 x Socket Head Cap Screw M3x10mm</p>	<p>Center Blade Grip Arm [H0085-S]</p>  <p>- 2 x Center Blade Grip Arms. - 2 x Socket Head Cap Screws M3x30mm. - 2 x Finishing Washers M3.</p>	<p>Canopy Locking [H0036-S]</p>  <p>- 2 x Canopy Lockings. - 2 x Canopy ORs.</p>	<p>Safety Lock Tail Boom [H0038-S]</p>  <p>- 1 x Safety Lock Tail Boom. - 1 x Finishing Washer M3. - 1 x Socket Head Cap Screw M3x8mm.</p>
<p>Tail Boom [H0092-S]</p>  <p>- 1 x Tail Boom. - 1 x Tail Boom Interface. - 1 x Locking Interface. - 2 x Tube Spacers. - 2 x Locking Element Tails. - 4 x Button Head Cap Screws M4x8mm.</p> <p>- 3 x Set Screws M3x20mm. - 2 x Washers Ø3.1xØ12x1.8mm. - 2 x Metric Hex Nylon Nuts M3 H4. - 2 x Vite Nylon Esa M8x14mm. - 2 x Metric Hex Nuts M8 H6.5. - 2 x Double Sided Tapes.</p>			
<p>Locking Element Tail [H0041-S]</p>  <p>- 2 x Locking Element Tails. - 4 x Metric Hex Nylon Nuts M3. - 2 x Double Sided Tapes.</p>	<p>Sliding Landing Gear [H0039-S]</p>  <p>- 4 x Sliding Landing Gears. - 4 x Socket Head Cap Screws M2.5x6mm.</p>	<p>Tail Servo Lock [H0040-S]</p>  <p>- 2 x Tail Servo Locks. - 2 x Servo Spacers. - 4 x Socket Head Cap Screws M2.5x12mm.</p>	<p>Battery Protection [H0042-S]</p>  <p>- 1 x Battery Protection.</p>

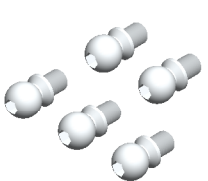

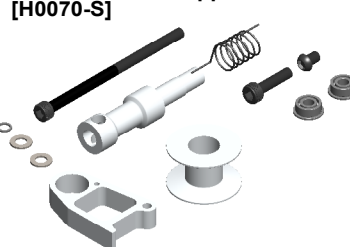
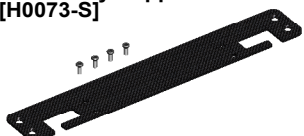
SAB HELI DIVISION

<p>Spacer Flybarless [H0043-S]</p>  <ul style="list-style-type: none"> - 3 x Spacer Flybarless. - 1 x Supporto Flybarless. - 1 x Flat Head Cap Screw M3x8mm. - 5 x Socket Head Cap Screws M3x6mm. 	<p>Linkage Tail Support [H0045-S]</p>  <ul style="list-style-type: none"> - 1 x Linkage Tail Support. - 2 x Socket Head Cap Screws M2.5x6mm. 	<p>Vertical Fin [H0046-S]</p>  <ul style="list-style-type: none"> - 1 x Vertical Fin. - 2 x Socket Head Cap Screws M3x12mm. - 2 x Finishing Washers M3. 	<p>Tail Side Plate [H0047-S]</p>  <ul style="list-style-type: none"> - 1 x Tail Side Plate. - 2 x Socket Head Cap Screws M3x12mm. - 2 x Finishing Washers M3. 	
<p>Tail Rotor Shaft [H0048-S]</p>  <ul style="list-style-type: none"> - 1 x Tail Rotor Shaft. - 2 x Set Screws M4x4mm. 	<p>26T Tail Pulley [H0103-S]</p>  <ul style="list-style-type: none"> - 1 x 26T Tail Pulley. - 1 x Set Screw M4x4mm. - 6 x Socket Head Cap Screws M2x5mm. 	<p>27T Tail Pulley [H0102-S]</p>  <ul style="list-style-type: none"> - 1 x 27T Tail Pulley. - 1 x Set Screw M4x4mm. - 6 x Socket Head Cap Screws M2x5mm. 	<p>Antenna Guide [H0050-S]</p>  <ul style="list-style-type: none"> - 2 x Antenna Guide. - 2 x Button Head Cap Screws M3x4mm. 	<p>Tail Rotor Hub [H0051-S]</p>  <ul style="list-style-type: none"> - 1 x Tail Rotor Hub. - 1 x Set Screw M4x4mm. - 2 x Socket Head Cap Screws M3x16mm.
<p>Tail Blade Grip [H0052-S]</p>  <ul style="list-style-type: none"> - 2 x Tail Blade Grips. - 2 x Socket Head Cap Screws M3x16mm. - 4 x Bearings $\phi 5x\phi 9x3$mm. 	<p>Tail Pitch Slider [H0053-S]</p>  <ul style="list-style-type: none"> - 1 x Tail Pitch Slider 01. - 1 x Tail Pitch Slider 02. - 1 x Tail Pitch Slider 03. - 1 x Spacer $\phi 8x\phi 9x3.2$mm. - 1 x Uniball M3x4 $\phi 5$H3. - 2 x Flanged Bearings $\phi 8x\phi 12x3.5$mm 	<p>Grip Link [H0056-S]</p>  <ul style="list-style-type: none"> - 2 x Grips Link. - 2 x Main Grip Link Bush. - 2 x Grip Link Bush. - 2 x Socket Head Cap Screws M2x12mm. - 2 x Socket Head Cap Screws M2x6mm. 	<p>Bell Crank Base [H0058-S]</p>  <ul style="list-style-type: none"> - 1 x Bell Crank Base. 	
<p>Bell Crank Lever [H0059-S]</p>  <ul style="list-style-type: none"> - 1 x Bell Crank Lever. - 1 x Bush Bell Crank. - 1 x Washer $\phi 3x\phi 4x0.5$mm. - 1 x Spacer $\phi 3x\phi 4x9.6$mm. - 1 x Socket Head Cap Screw M3x22mm. - 2 x Flanged Bearings $\phi 3x\phi 7x3$mm. 	<p>Tail Case Spacer [H0061-S]</p>  <ul style="list-style-type: none"> - 2 x Tail Case Spacers. - 4 x Socket Head Cap Screws M3x8mm. 	<p>Spacer $\phi 7x\phi 9x0.5$mm [H0062-S]</p>  <ul style="list-style-type: none"> - 4 x Spacers $\phi 3x\phi 4x0.5$mm 	<p>Uniball M3x4 $\phi 5$H18 [H0063-S]</p>  <ul style="list-style-type: none"> - 1 x Uniball M3x4 $\phi 5$H18 	
<p>Uniball M2 $\phi 5$H6 [H0064-S]</p>  <ul style="list-style-type: none"> - 5 x Uniballs M2 $\phi 5$H6. - 5 x Uniball Spacers. - 5 x Socket Head Cap Screws M2x8mm. - 5 x Socket Head Cap Screws M2x6mm. 	<p>Uniball M3x4 $\phi 5$H3 [H0065-S]</p>  <ul style="list-style-type: none"> - 5 x Uniballs M3x4 $\phi 5$H3.5. 	<p>Plastic Ball Link [H0066-S]</p>  <ul style="list-style-type: none"> - 10 x Plastic Ball Links 	<p>Belt Tensioner Support [H0070-S]</p> 	
<p>RX Battery Support [H0073-S]</p>  <ul style="list-style-type: none"> - 1 x RX Battery Support. - 4 x Flat Head Cap Screws M2.5x5mm. 	<p>Landing Gear Struts [H0074-S]</p>  <ul style="list-style-type: none"> - 4 x Landing Gear Struts. - 4 x Button Head Cap Screws M4x6mm. - 4 x Button Head Cap Screws M4x10mm. 	<p>Servo Spacer [H0075-S]</p>  <ul style="list-style-type: none"> - 10 x Servo Spacers. 	<ul style="list-style-type: none"> - 1 x Belt Tensioner Support. - 1 x Tail Belt Idler. - 1 x Belt Tensioner Arm. - 2 x Flanged Bearings $\phi 3x\phi 7x3$mm - 2 x Flanged Bearings $\phi 5x\phi 9x3$mm - 1 x Socket Head Cap Screw M3x50mm. - 1 x Washer $\phi 3x\phi 4x0.5$mm. - 1 x Socket Head Cap Screw M3x12mm. - 2 x Washers $\phi 3.2x\phi 6x0.5$mm. - 1 x Button Head Cap Screw M3x4mm. - 1 x Spring De8/df0.5/LL8. 	



**Washer $\varnothing 3.1 \times \varnothing 12 \times 1.8 \text{mm}$
[H0078-S]**

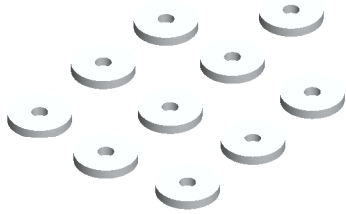

- 10 x Washers $\varnothing 3.1 \times \varnothing 12 \times 1.8 \text{mm}$.

**Blade Grip Arm
[H0087-S]**

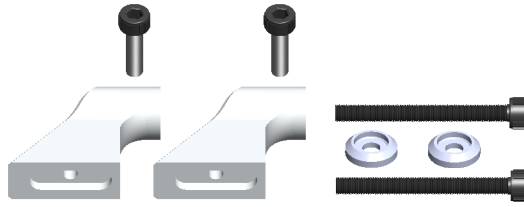

- 2 x Blade Grip Arms.
- 2 x Socket Head Cap Screws M3x10mm.
- 2 x Finishing Washers M3.
- 2 x Socket Head Cap Screws M3x30mm

**Bush One Way
[H0110-S]**



- 4 x Bush One Ways.

[BW2630]



- SAB 630mm Carbon Fiber Main Blade.

[BW5105]



















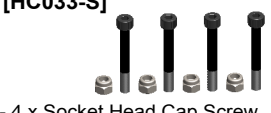

























- SAB 105mm Carbon Fiber Tail Blade.

**Canopy 630
[H0095-S]**







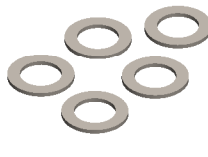
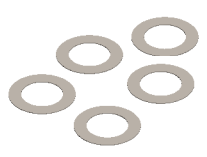
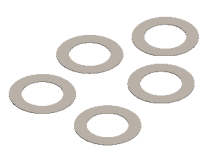



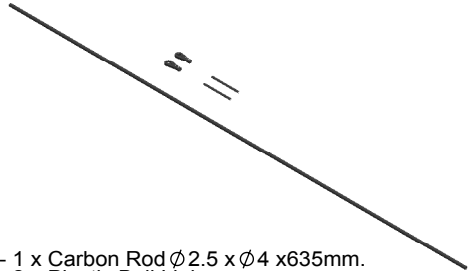
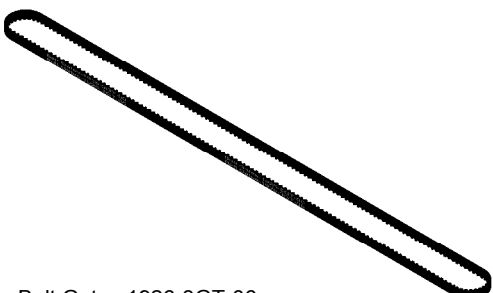

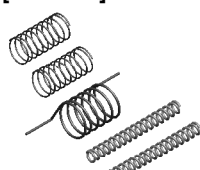

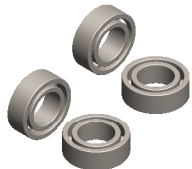

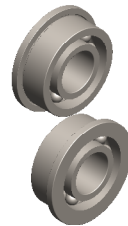



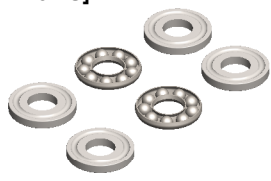
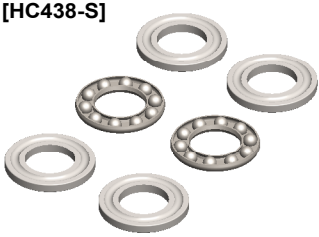
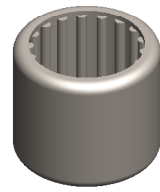

- 1 x Canopy 630.
- 1 x Canopy Mouse 80cm.

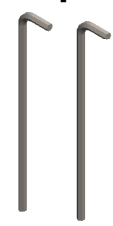

<p>[HC002-S]</p>  <p>-10 x Socket Head Cap Screws M2x5mm.</p>	<p>[HC004-S]</p>  <p>-10 x Socket Head Cap Screws M2x6mm.</p>	<p>[HC008-S]</p>  <p>-10 x Socket Head Cap Screws M2x8mm.</p>	<p>[HC014-S]</p>  <p>-10 x Socket Head Cap Screws M2x12mm.</p>	<p>[HC018-S]</p>  <p>-10 x Socket Head Cap Screws M2.5x6mm.</p>	<p>[HC020-S]</p>  <p>-10 x Socket Head Cap Screws M2.5x8mm.</p>
<p>[HC026-S]</p>  <p>-10 x Socket Head Cap Screws M2.5x12mm.</p>	<p>[HC033-S]</p>  <p>- 4 x Socket Head Cap Screw Shouldered M2.5x19mm. - 4 x Metric Hex Nylon Nuts M2.5H3.5.</p>	<p>[HC038-S]</p>  <p>- 5 x Button Head Cap Screws M3x4mm.</p>	<p>[HC044-S]</p>  <p>-10 x Socket Head Cap Screws M3x6mm.</p>	<p>[HC050-S]</p>  <p>-10 x Socket Head Cap Screws M3x8mm.</p>	<p>[HC056-S]</p>  <p>-10 x Socket Head Cap Screws M3x10mm.</p>
<p>[HC062-S]</p>  <p>-10 x Socket Head Cap Screws M3x12mm.</p>	<p>[HC068-S]</p>  <p>-10 x Socket Head Cap Screws M3x16mm.</p>	<p>[HC074-S]</p>  <p>-2 x Socket Head Cap Screw Shouldered M3x16mm. -2 x Metric Hex Nylon Nuts M3H4.</p>	<p>[HC086-S]</p>  <p>-5 x Socket Head Cap Screws M3x22mm.</p>	<p>[HC090-S]</p>  <p>-5 x Socket Head Cap Screws M3x30mm.</p>	<p>[HC092-S]</p>  <p>-2 x Socket Head Cap Screw M3x50mm Shouldered.</p>
<p>[HC096-S]</p>  <p>-10 x Button Head Cap Screws M4x6mm.</p>	<p>[HC098-S]</p>  <p>-10 x Button Head Cap Screws M4x8mm.</p>	<p>[HC100-S]</p>  <p>-10 x Button Head Cap Screws M4x10mm.</p>	<p>[HC104-S]</p>  <p>-10 x Socket Head Cap Screws M4x22mm.</p>	<p>[HC111-S]</p>  <p>-5 x Socket Head Cap Screws M4x24mm Shouldered.</p>	
<p>[HC114-S]</p>  <p>- 2 x Socket Head Cap Screw Shouldered M5x30mm. - 2 x Metric Hex Nylon Nuts M5H4.8.</p>	<p>[HC122-S]</p>  <p>-10 x Button Head Cap Screws M6x10mm.</p>	<p>[HC128-S]</p>  <p>-5 x Flat Head Cap Screws M2.5x5mm.</p>	<p>[HC134-S]</p>  <p>-5 x Flat Head Cap Screws M3x8mm.</p>	<p>[HC140-S]</p>  <p>- 10 x Set Screw M2.5x18mm.</p>	<p>[HC146-S]</p>  <p>- 10 x Set Screws M2.5x15mm.</p>
<p>[HC150-S]</p>  <p>- 10 x Set Screws M3x20mm.</p>	<p>[HC152-S]</p>  <p>- 10 x Set Screws M4x4mm.</p>	<p>[HC158-S]</p>  <p>- 5 x Set Screws M5x20mm.</p>	<p>[HC164-S]</p>  <p>- 5 x Vite Nylon Esa Cap M8x14mm.</p>	<p>[HC170-S]</p>  <p>- 10 x Washers Ø2.2xØ5x0.3mm.</p>	<p>[HC176-S]</p>  <p>- 5 x Washers Ø3xØ4x0.5mm.</p>
<p>[HC180-S]</p>  <p>- 10 x Washers Ø3.3xØ6x0.5mm.</p>	<p>[HC182-S]</p>  <p>- 10 x Washers Ø3.3xØ9x0.8mm.</p>	<p>[HC188-S]</p>  <p>- 5 x Washers Ø5.3xØ15x1mm.</p>	<p>[HC194-S]</p>  <p>- 5 x Washers Ø6xØ14x1.5mm.</p>	<p>[HC200-S]</p>  <p>- 10 x Metric Hex Nylon Nuts M2.5H3.5.</p>	<p>[HC206-S]</p>  <p>- 10 x Metric Hex Nylon Nuts M3H4.</p>
<p>[HC212-S]</p>  <p>- 10 x Metric Hex Nylon Nuts M4 H5.</p>	<p>[HC218-S]</p>  <p>- 5 x Metric Hex Nylon Nuts M5 H4.8.</p>	<p>[HC224-S]</p>  <p>- 5 x Metric Hex Nuts M8 H6.5.</p>	<p>[HC230-S]</p>  <p>- 5 x Shim Washers Ø10xØ16x1mm.</p>	<p>[HC232-S]</p>  <p>- 5 x Shim Washers Ø10xØ16x0.2mm.</p>	<p>[HC234-S]</p>  <p>- 5 x Shim Washers Ø10xØ16x0.1mm.</p>

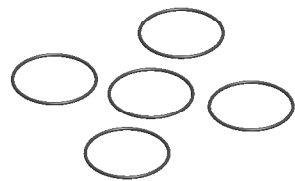

<p>[HC237-S]</p>  <p>- 1 x Carbon Rod $\varnothing 2.5 \times \varnothing 4 \times 635$mm. - 2 x Plastic Ball Links. - 2 x Threaded Rods M2.5x40mm.</p>	<p>[HC324-S]</p>  <p>- 1 x Belt Gates 1926-3GT-06.</p>	<p>[HC308-S]</p>  <p>- 1 x Belt Gates 240-3MGT-13.</p>			
<p>[HC315-S]</p>  <p>- 2 x Springs de 5.8/df 0.3/LL9. - 1 x Spring de 8/df 0.5/LL8. - 2 x Springs de 3/df 0.5/LL12.</p>	<p>[HC402-S]</p>  <p>- 4 x Flanged Bearings $\varnothing 3 \times \varnothing 7 \times 3$mm.</p>	<p>[HC406-S]</p>  <p>- 4 x Bearings $\varnothing 5 \times \varnothing 9 \times 3$mm.</p>	<p>[HC410-S]</p>  <p>- 4 x Flanged Bearings $\varnothing 5 \times \varnothing 9 \times 3$mm.</p>	<p>[HC414-S]</p>  <p>- 2 x Flanged Bearings $\varnothing 6 \times \varnothing 13 \times 5$mm.</p>	<p>[HC418-S]</p>  <p>- 2 x Flanged Bearings $\varnothing 8 \times \varnothing 12 \times 3.5$mm.</p>
<p>[HC420-S]</p>  <p>- 2 x Bearings $\varnothing 10 \times \varnothing 15 \times 4$mm.</p>	<p>[HC422-S]</p>  <p>- 4 x Bearings $\varnothing 10 \times \varnothing 19 \times 5$mm.</p>	<p>[HC426-S]</p>  <p>- 2 x Bearings $\varnothing 12 \times \varnothing 24 \times 6$mm.</p>	<p>[HC430-S]</p>  <p>- 2 x Bearing Rads $\varnothing 30 \times \varnothing 37 \times 4$mm.</p>	<p>[HC434-S]</p>  <p>- 2 x Thrust Bearings $\varnothing 4 \times \varnothing 9 \times 4$mm.</p>	
<p>[HC438-S]</p>  <p>- 2 x Thrust Bearings $\varnothing 10 \times \varnothing 18 \times 5.5$mm.</p>	<p>[HC442-S]</p>  <p>- 1 x One Way Bearing $\varnothing 10 \times \varnothing 14 \times 12$mm.</p>	<p>[HA001-S]</p>  <p>- 1 x Foam Blade Holder.</p>	<p>[HA002-S]</p>  <p>- 2 x Hex Wrenches 2.5mm.</p>	<p>[HA016-S]</p>  <p>- 1 x Plastic Wrench Nut M8 & M6.</p>	
<p>[HA006-S]</p>  <p>- 1 x Canopy Mousse 80cm.</p>	<p>[HA008-S]</p>  <p>- 5 x Canopy ORs.</p>	<p>[HA0010-S]</p>  <p>- 1 x Cable Pass.</p>	<p>[HA011-S]</p>  <p>- 2 x Canopy Grommets.</p>	<p>[HA012-S]</p>  <p>- 5 x Battery ORs.</p>	

WWW.GOBLIN-HELICOPTER.COM

SAB HELI DIVISION